

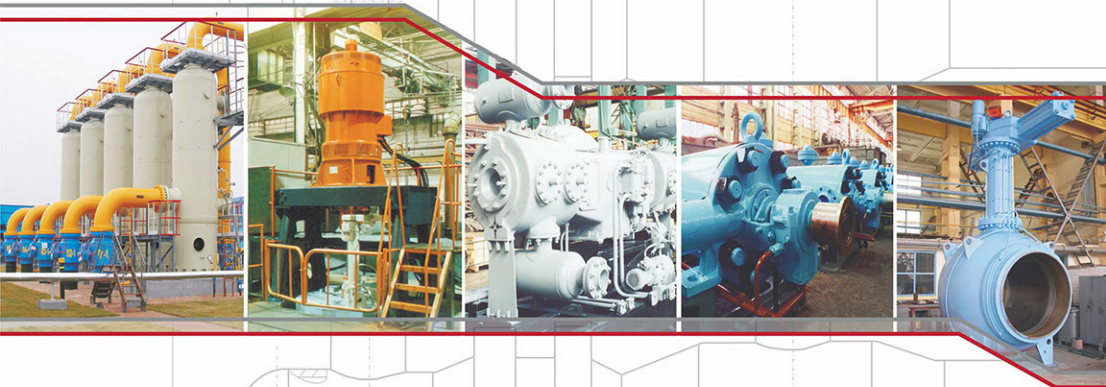

58 Gorkogo Str., Sumy, 40004, Ukraine  
tel.: +38 0542 77 77 94, 68 69 15, 77 50 00  
fax: +38 0542 22 63 62  
sales@frunze.com.ua  
snpo.ua



HEAT EXCHANGERS

*Technical Catalogue*

# HEAT EXCHANGERS

“Sumy NPO” PJSC

Representation office in Kiev:  
tel./fax: +38 044 280 98 19, 280 98 28  
frunze-kiev@ukr.net

Branch office in Turkmenistan (Ashgabat):  
tel./fax: +993 12 36 24 81  
frunzeturkm@mail.ru  
frunzeturkm@rambler.ru

Branch office in the Republic of Azerbaijan (Baku):  
tel./fax: +994 12 447 45 68, 497 12 48  
frunze@azeurotel.com

Representation office in the Russian Federation (Moscow):  
tel.: +7 495 664 21 73  
fax: +7 495 745 88 31  
a.efremov@frunze.msk.ru

snpo.ua

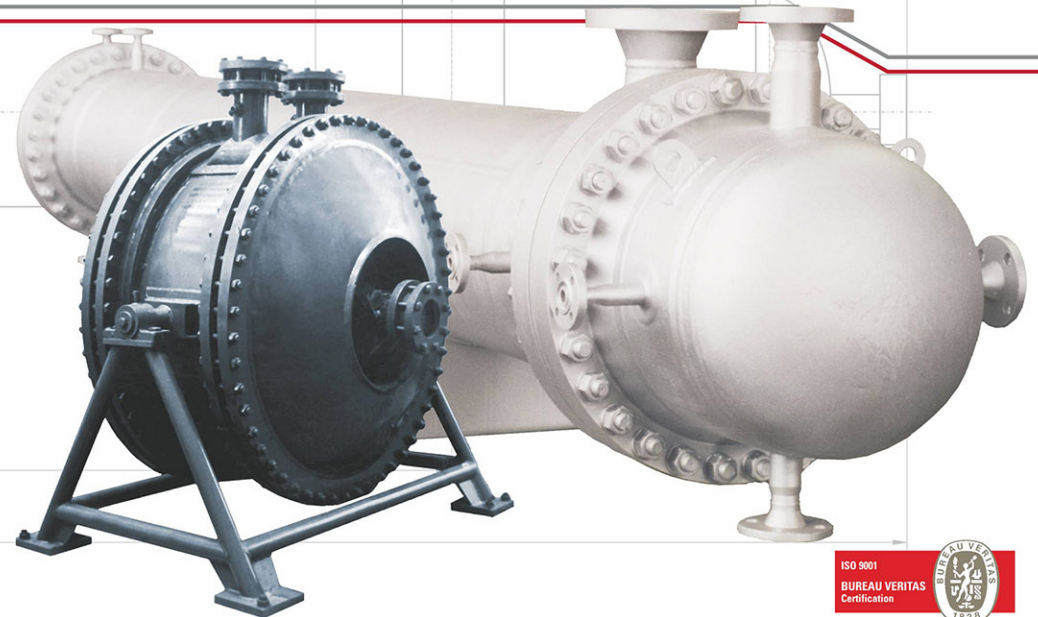

“Sumy NPO” PJSC, founded in 1896, is among eastern Europe's largest machine-building enterprises focused on manufacturing of equipment and providing integral solutions for oil, gas, chemical, petrochemical and power industries.

Product list of the company includes but is not limited to unique types of compressor equipment, pumps, centrifuges, gas ball valves, tanks, pressure vessels, mass- and heat exchangers as well as packaged facilities, namely: gas treatment units (drying, H<sub>2</sub>S removal, fractioning etc), compressor stations, fuel gas skids and other products individually designed, fabricated and tested according to specific project requirements.

Products diversity owes to company's advanced engineering and manufacturing capabilities. Facilities incorporate dedicated yards equipped with the most advanced equipment and cutting edge quality control facilities. Testing facilities comply with the strictest requirements to materials testing, product performance, acceptance and full scale tests of the manufactured products.

High quality of the products is ensured by means of quality assurance and control system that fully complies with international standard ISO 9001. All products comply with the requirements of domestic and international standards.

Products and solutions for chemical, petrochemical oil & gas industry is one of the key expertise of “Sumy NPO” PJSC .

Equipment produced by the company operates at almost all chemical plants in CIS countries.

Heat exchangers were supplied for process lines of concentrated nitric acid, distillate, oil and gas refineries.

In recent years heat exchangers were supplied to the following chemical plants: GrodnoAzot JSC (Belarus), Alvigo JSC (Lithuania), Shchekinoazot JSC (Russia), oil and gas refineries of Surgutneftegaz JSC (Russia), CS Astara (Azerbaijan), BCS Zevardy, BCS Gazli (Uzbekistan), BCS Naiyp (Turkmenistan), etc.



<b>1. Spiral heat exchangers</b>	<b>5</b>
<b>2. Wound heat exchangers</b>	<b>11</b>
<b>3. Shell and tube heat exchangers with floating head, shell and tubes heat exchangers with U-shaped tubes and tube bundles to them as per TU 3612-023-00220302-01</b>	<b>14</b>
TPV and KhPV types heat exchangers with 3000 mm tubes length	22
KP type heat exchangers	23
TU type heat exchangers	25
Heat exchange surface of TP and KhP type heat exchangers	27
Heat exchange surface of KP type heat exchangers	28
Heat exchange surface of TU type heat exchangers	29
Materials for heat exchangers manufacturing	30
Weight of TP type heat exchangers	31
Weight of KhP type heat exchangers	35
Weight of KP type heat exchangers	39
Weight of TU type heat exchangers	41
Layout of foundation bolts holes in supports	42
Tube bundle of TP, KhP type heat exchangers	43
Basic dimensions of tube bundles of TP and KhP type heat exchangers	44
Tube bundle of KP type heat exchangers	46
Tube bundle of TU type heat exchangers	48
Basic dimensions of tube bundles of TU type heat exchangers	48
Weight of tube bundles for TP and KhP types heat exchangers at tubes holes layout at squares apexes	50
Weight of tube bundles for TP and KhP types heat exchangers at tubes holes layout at equilateral triangles corners	53
Weight of tube bundles for KP type heat exchangers at tubes holes layout at equilateral triangles corners	56
Weight of tube bundles for TU type heat exchangers at tubes holes layout at equilateral triangles corners	58
Order form for heat exchanger or tube bundle manufacturing	60
MO-53-4 type oil coolers	61
Materials for oil coolers assembly units and components manufacturing	62
<b>4. Shell and tube heat exchangers with fixed sheets and shell and tube heat exchangers with expansion pipe on shell as to Specification TU 3612-024-002203002-2</b>	<b>63</b>
TNG, TKG, KhNG, KhKG types one pass through tubes heat exchangers	66
TNV, TKV, KhKV types one pass through tubes heat exchangers	67
TNG, TKG types multi-pass through tubes heat exchangers	68
TNV, TKV types multi-pass through tubes heat exchangers	69
Basic parameters of TN and TK types heat exchangers	70
KhNG, KhKG types multi-pass through tubes heat exchangers	74
KhNV, KhKV types multi-pass through tubes heat exchangers	75
Basic parameters of KhN and KhK types heat exchangers	76
KNG, KKG types multi-pass through tubes heat exchangers	79
KNV, KKV types Multi-pass through tubes heat exchangers	80
Basic parameters of KN and KK types heat exchangers	81
IN-1, IK-1 types heat exchangers	83



IN-2, IK-2 heat exchangers	84
Basic parameters of IN and IK heat exchangers	85
Heat-exchange surface of TN, TK, KhN, KhK heat exchangers	87
Heat-exchange surface of KN and KK heat exchangers	89
Heat-exchange surface of IN and IK heat exchangers	91
Materials for heat exchangers manufacturing	93
Weight of TN, TK heat exchangers	95
Weight of KhK, KhN heat exchangers	99
Weight of KN, KK heat exchangers	102
Weight of IN, IK heat exchangers	105
Layout of Bolt Holes in Supports in TN, TK, KhN, KhK, KN, KK, IN, IK Heat Exchangers	106
Layout of Supports and Nozzles in TN, TK, KhN, KhK, KN, KK, IN, IK Heat Exchangers	107
Limit Working Pressure for Heat Exchangers	108
Order Form for heat exchanger manufacturing	109
<b>5. “Gas-gas” heat exchangers</b>	<b>111</b>
Materials for “Gas-Gas” type heat exchangers manufacturing	120
“Gas-Gas” heat exchanger of type 1	121
“Gas-Gas” heat exchanger of type 2	122
“Gas-Gas” heat exchanger of type 3	123
“Gas-Gas” heat exchanger of type 4	124
Table of Nozzles	125
<b>6. Vaporizers and Tube Bundles to Them</b>	<b>126</b>
IU Type Vaporizer	128
IP Type Vaporizer	129
Layout of Support Foundation Bolts Holes	130
Basic Parameters of Vaporizers with Vapor Space	131
Vaporizers and Tube Bundles to Them	132
Heat Transferring Surface of IP and IU Types Vaporizers	133
Weight of IP and IU Types Vaporizers	134
Materials for Vaporizers Manufacturing	135
Two-Passes Tube Bundles for Vaporizers of IU Type	136
Two-Passes Tube Bundles for Vaporizers of IP Type	137
Basic Dimensions of Tube Bundles for Vaporizers of IP and IU Types	138
Weight of Tube Bundles for Vaporizers of IP and IU Types	139
Questionnaire for Order of Heat Exchanger as to Specification TY 3612-013-00220302-99	140
Order Form for Heat Exchanger Manufacturing as to Specifications TY 3612-013-00220302-99	141
Order Form for Heat Exchanger Tube Bundles Manufacturing as to Specifications TY 3612-013-00220302-99	142
<b>7. Thermosyphon Vaporizers</b>	<b>143</b>
Thermosyphon Vaporizers	144
Basic Parameters of Thermosyphon Vaporizers	145
Thermosyphon Vaporizers of INT and IKT Types - Design 1	146
Thermosyphon Vaporizers of INT and IKT Types - Design 2	147
Basic Dimensions of INT-1, INT-2, IKT-1, IKT-2 Vaporizers	148
IPT Vaporizers with Tube Length 3000 mm	150



IPT Vaporizers with Tube Length 6000 mm	151
Basic Dimensions of IPT Vaporizer with Tubes Length 3000 mm, 6000 mm	152
Heat Exchange Surface of INT and IKT Vaporizers	154
Heat Exchange Surface Along the Outside Pipe Diameter and the Area of Clear Openings in the Pipes of Floating Head Thermosyphon Evaporators (FHTE)	155
Layout of Nozzles, Foundation Bolts Holes for INT and IKT Vaporizers	156
Materials for Vaporizers Manufacturing	157
Weight of INT and IKT Vaporizers	159
Weight of IPT Vaporizers	161
Order Form for Vaporizer Manufacturing as to Specifications TU 3612-005-00220802-98	165
<b>8. Steam-Water and Water-to-Water Heaters for Heat Supply Networks</b>	<b>167</b>
Steam-Water Single-Stage Heater	169
Basic Dimensions of Heaters	170
Heat Exchange Surface of Heaters	171
Layout of Foundation Bolts Holes in Supports	172
Water-to-Water Single-Stage Heater	173
Water-to-Water Multi-Stage Heater	174
Heat Exchange Surface of Water-to-Water Heaters	175
<b>9. Certificates and Approvals</b>	<b>176</b>



# Spiral Heat Exchangers

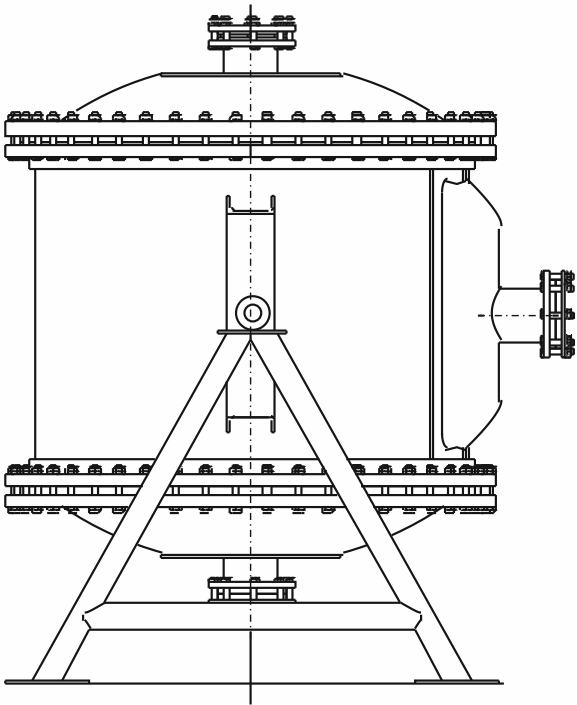

Spiral heat exchangers are recuperative heat-exchange apparatus designed for heat transfer from hot medium to a cold one through heat-transfer surface made of coiled strip spirally wound forming two non-intercommunicating rectangular cross-section spiral. In order to provide spirals with sufficient buckling strength under linear external pressure, as well as to fix the distance between the spirals, the carrier pins and spacers are installed.

Heat exchangers are applied for heat exchange between operating media: liquid-liquid, gas-gas and gas-liquid, as well as vapor and vapor-gas mixture condensation. Heat exchangers can operate both under vacuum and under pressure of operating medium up to 10 kgf/cm<sup>2</sup>, within the temperature range of operating medium from minus 20°C to +200°C. Spiral heat exchangers can be made of any rolled material subjected to cold treatment and welding.

Spiral heat exchangers are heavy-duty apparatus, they show high and relatively stable heat transfer coefficient, structure compactability, increased coolant rate, uniformity of coolant flow area in the canal operating space; due to this heat exchanger has low radiation surface contamination is less than in apparatus of another type that enables to operate heat exchanger for prolonged period without cleaning.

Operating medium contra-flow motion is performed in the spiral heat exchanger. Cold medium enters the apparatus at the periphery and is located in the external channel; due to this heat exchanger has low radiation losses. Hydraulic resistance of spiral heat exchangers is lower than of tube-and-shell heat exchangers given the same liquid flow rate.

By the method of channel sealing the heat exchangers can be manufactured:

type 1 – with dead channels

type 2 – with end-to-end channel.

Spiral heat exchangers with dead channels are the most commonly used. Each of two channels of such heat exchanger is welded by one end from mutually opposite sides. Such sealing method prevents coolant mixing in case of gasket joint leakage. After heat exchanger covers removal both channels can be easily cleaned.

Heat exchangers with dead channels can be made in the following versions:

version 1 – with flat covers, applied for heat exchange between operating media: liquid-liquid, gas-gas and gas-liquid;

version 2 – with conical cover, applied for heat exchange between operating media that change their aggregative state in the apparatus – during vapor and vapor-gas mixture condensation.

Heat exchangers used for steam condensing (condensers) are installed in a vertical position only. Steam or steam-gas mixture goes through the conical cover of the heat exchanger and into most of the spiral curves of the open channel simultaneously, except for a few external curves. The vertical position of channels excludes the possibility of condensate plugs and fluid hammers. The produced condensate flows down along the vertical channel walls, is collected in the bottom part of the heat exchanger and flows through the spiral into the condensate drain nozzle located in the bottom part of the overflow chamber. The remaining non-condensed part of the medium goes through a few of the external channel curves via a spiral, becomes cooled and is drained away through a nozzle.

In type 2 heat exchangers (with end-to-end channels), one channel is produced to be open on both sides, which allows to carry out its cleaning while the covers are removed, and the second one, the so-called “blind” channel, is welded on both ends. The “blind” channel cannot be cleaned via mechanical means, so it is used for the supply of mediums that do not leave any residue.

Heat exchangers with an end-to-end channel can be manufactured in the following makes:

make 1 – used for pre-heating of waste water and other polluted mediums. They are coiled with channels of varying breadth: the steam or water supply channel is narrow and is called “blind”, and the channel for polluted medium is wide, end-to-end. The machines have two flat covers, one of which is screw-on and easy to remove, allowing to reduce the disassembly time of the heat exchanger for the end-to-end channel cleaning;

make 2 – used for pre-heating or cooling of high-viscosity liquids and gases. The machines are furnished with two spherical covers, allowing the high-viscosity medium to go into all the curves of the end channel at the same time.



# 7 Spiral Heat Exchangers

Spiral heat exchanger of 1 type, design 1,2

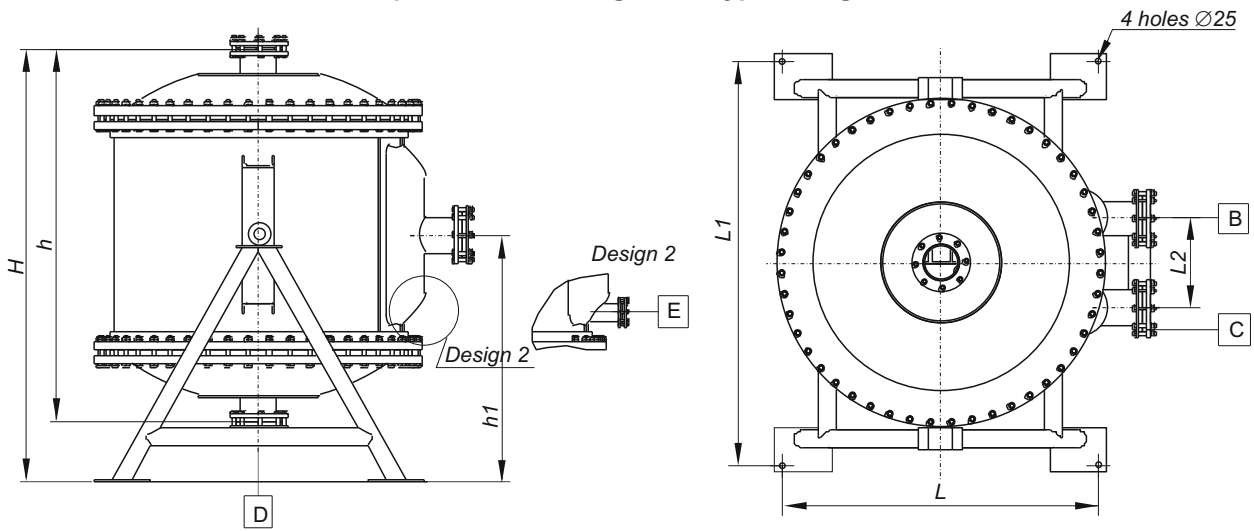

Spiral heat exchanger of 2 type, design 1

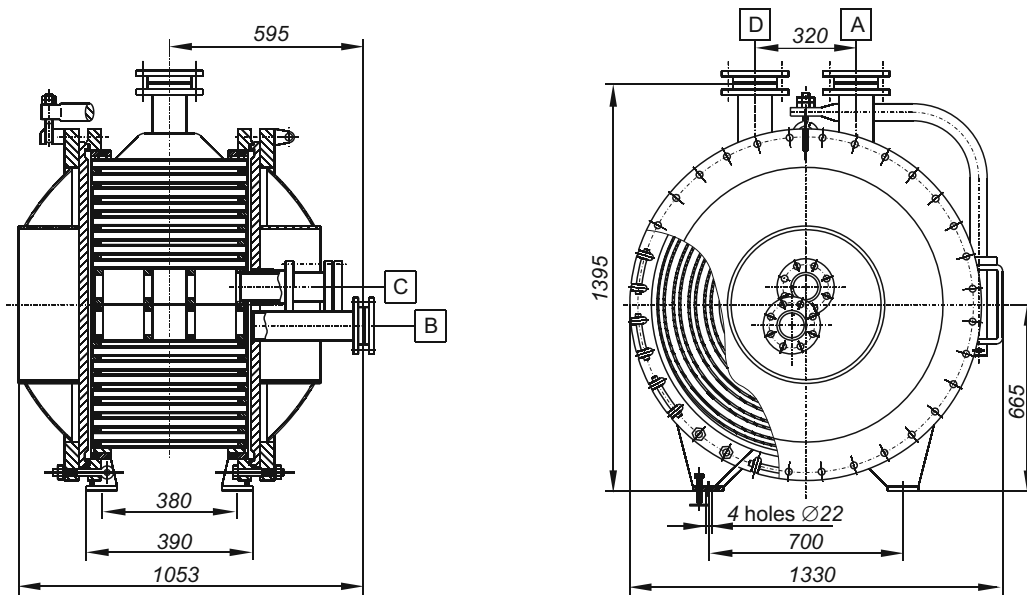

Spiral heat exchanger of 2 type, design 2

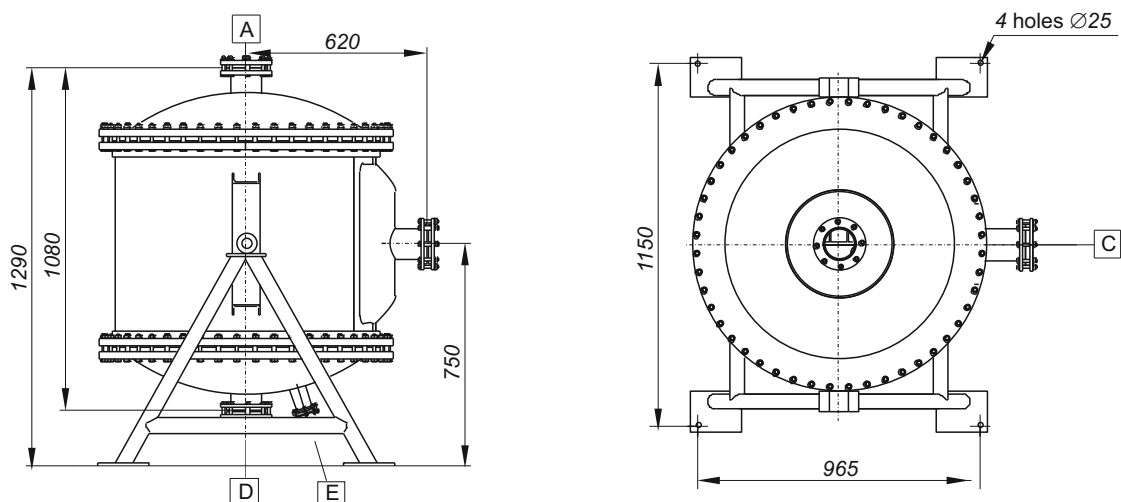



## 8 Spiral Heat Exchangers

Types and basic parameters of spiral heat exchangers are listed in the Table 1.1.

For spiral heat exchangers manufacturing besides of steel, specified in steel grades catalog, another materials can be used as well.

Basic dimensions and characteristics of spiral heat exchangers are given in corresponding tables.

Spiral heat exchangers with dimensions which are not specified in the catalog, if necessary can be designed and manufactured in accordance with State Standard GOST 12067.

The example of designation:

**Heat exchanger S1-31.5-6-1K**

Legend:

- S – spiral;
- 1 – type of heat exchanger;
- 31.5 – heat exchange surface, m<sup>2</sup>;
- 6 – nominal pressure, kgf/cm<sup>2</sup>;
- 1 – design;
- K – material  
(K – corrosion-resistant,  
U – carbon).

Types and basic parameters of spiral heat exchangers

Table 1.1

Type	Design	Purpose	Nominal heat exchange surface, m <sup>2</sup>	Pressure, MPa (kgf/cm <sup>2</sup> )		Working media temperature, °C
				Excess	Residual	
1 - with dead-end channels	1 – with plain cover	For heat-exchanging between media: liquid-liquid, gas-gas, liquid-gas	10; 20; 31.5; 40; 50; 63; 80; 100	to 1.0 (10)	not lower 0.08 (0.8)	From -20 to +20
	2 – with cone-shaped cover	For steam condensation and steam-and-gas mix heat exchanging				
2 -with end-to-end channels	1 – with plain flap cover	For sewage water and other polluted media heating	20	0.8 (8)	-	
	2 – with spherical cover	For high-viscosity liquids and gases				

Basic dimensions (mm) and characteristics of heat exchangers of type 1, design 1 made of stainless steel

Table 1.2

Heat exchange surface, m <sup>2</sup>	Channel width, mm	H	h	h <sub>1</sub>	l	A	A <sub>1</sub>	A <sub>2</sub>	DN	Width of strip, mm	Length of channel, m	Channel cross-sectional area, m <sup>2</sup>	Flow capacity at velocity 1 m/s, m <sup>3</sup> /h	Weight, kg		Strip material (as to GOST 5632-72)
														P, MPa		
														0.6	1.0	
10	12	1170	940	700	560	900	1060	250	65	400	12.5	0.0048	17.28	970	1170	Steel 12X18H10T
20		1230	1000	730	620	960	1380	320	100	400	25	0.0048	17.28	1720	1770	Steel 12X18H10T
31.5		1350	1100	800	770					1485	500	31.5	0.006	21.6	2300	2560
40		1850	1600	1050	700	1330	1300	400	150	1000	20	0.012	43.2	2430	2760	Steel 12X18H10T
50		1930	1660	1100	720	1400	1460				25			2990	3460	
63					810		1640				31.5			3800	4260	
80					900		1800				40			4700	5450	
100		2180	1910	1225	900	1960	1250	40	0,015	54	6050	6680				



Basic dimensions (mm) and characteristics of heat exchangers of type 1, design 1 made of carbon steel

Table 1.3

Heat exchange surface, m <sup>2</sup>	Channel width, mm	H	h	h <sub>1</sub>	l	A	A <sub>1</sub>	A <sub>2</sub>	DN	Width of strip, mm	Length of channel, m	Channel cross-sectional area, m <sup>2</sup>	Flow capacity at velocity 1 m/s, m <sup>3</sup> /h	Weight, kg		Strip material (as to GOST 5632-72)
														P, MPa		
														0.6	1.0	
20	12	1610	1300	960	630	1230	1150	250	100	700	14.3	0.0084	30.24	1650	1680	Ст3сп4
31.5							1350	320			22.5			2600	2630	
40							1450	320			28.6			3200	3230	
50		2030	1760	1150	720	1525	1500	400	150	1100	22.7	0.0138	49.68	3800	3960	Ст3сп5
63							1585				28.6			4740	4760	
80		1930	1660	1100	900	1400	1800	400	150	1000	40	0.012	43.2	5430	5450	
100		2180	1910	1225			1960			1250				0.015	54	

Basic dimensions (mm) and characteristics of heat exchangers of type 1, design 2 made of corrosion-resistant steel

Table 1.4

Heat exchange surface, m <sup>2</sup>	Channel width, mm	H	h	h <sub>1</sub>	l	L	L <sub>1</sub>	L <sub>2</sub>	A	B, C, D	E	Width of strip, mm	Length of channel, m	Channel cross-sectional area, m <sup>2</sup>	Flow capacity at velocity 1 m/s, m <sup>3</sup> /h	Weight, kg		Strip material (as to GOST 5632-72)	
																P, MPa			
																0.6	1.0		
10	12	1230	1000	700	560	900	1060	250	200	65	50	400	12.5	0.123	0.0048	17.28	960	1160	Steel 12X18H10T
20							1290	1060	730				620				960	1380	25
31.5		1410	1160	800	770	960	1485	320	250	100	65	500	31.5	0.337	0.006	21.6	2200	2470	Steel 10X17H13M2T
40		1910	1660	1050	700	1330	1300	400	300	150	80	1000	20	0.208	0.012	43.2	2420	2700	Steel 12X18H10T
50		1990	1720	1100	720	1460	25						0.264	2920			3400		
63					810	1640	31.5	0.337	3700	4200									
80					900	1800	40	0.432	4550	5000									
100		2250	2000	1270	900	1960	1250	40	0.432	0.015	54	5700	5900						



# 10 Spiral Heat Exchangers

Basic dimensions (mm) and characteristics of heat exchangers of type 1, design 2 made of carbon steel

Table 1.5

Heat exchange surface, m <sup>2</sup>	Channel width, mm		H	h	h <sub>1</sub>	l	L	L <sub>1</sub>	L <sub>2</sub>	A	B, C, D	E	Width of strip, mm	Length of channel, m	Channel cross-sectional area, m <sup>2</sup>		Flow capacity at velocity 1 m/s, m <sup>3</sup> /h	Weight, kg		Strip material (as to GOST 5632-72)	
	For I working medium	For II working medium													P, MPa						
															0.6	1.0					
20	12	1610	1360	900	630	1230	1150	250	250	100	65	700	14.3	0.123	0.0084	30.24	1580	1650	Ст3сп4		
31.5							1350	320					22.5	0.236			2500	2600			
40							1450	28.6					0.34	3050			3200				
50	12	2090	1820	1150	720	1525	1500	400	300	150	80	1100	22.7	0.275	0.0138	49.68	3750	3940	Ст3сп5		
63							1585						28.6	0.336			4720	4740			
80							1800						1000	31.5			0.012	5420		5430	
100							1960						1250	40			0.43	54		5910	5940
							2250														

Basic dimensions (mm) and characteristics of heat exchangers of type 2, design 1

Table 1.6

Heat exchange surface, m <sup>2</sup>	Channel width, mm		A, B, C, D	Width of strip, mm	Length of channel, m	Channel cross-sectional area, m <sup>2</sup>		Flow capacity at velocity 1 m/s, m <sup>3</sup> /h		Weight, kg	Strip material (as to GOST 5632-72)
	Wide	Narrow				Wide	Narrow	Wide	Narrow		
20	25	12	100	500	20	0.0125	0.006	45	21.6	2400	Steel 10X17H13M2T

Basic dimensions (mm) and characteristics of heat exchangers of type 2, design 2

Table 1.7

Heat exchange surface, m <sup>2</sup>	Channel width, mm	A, B	C, D	Width of strip, mm	Length of channel, m	Channel cross-sectional area, m <sup>2</sup>		Flow capacity, m <sup>3</sup> /h		Weight, kg	Strip material (as to GOST 5632-72)
						End-to-end	Spiral	at velocity 0.01 m/s			
20	8	150	70	500	20	0.16	0.006	45	21.6	1200	Steel 10X17H13M2T



# Wound Heat Exchangers

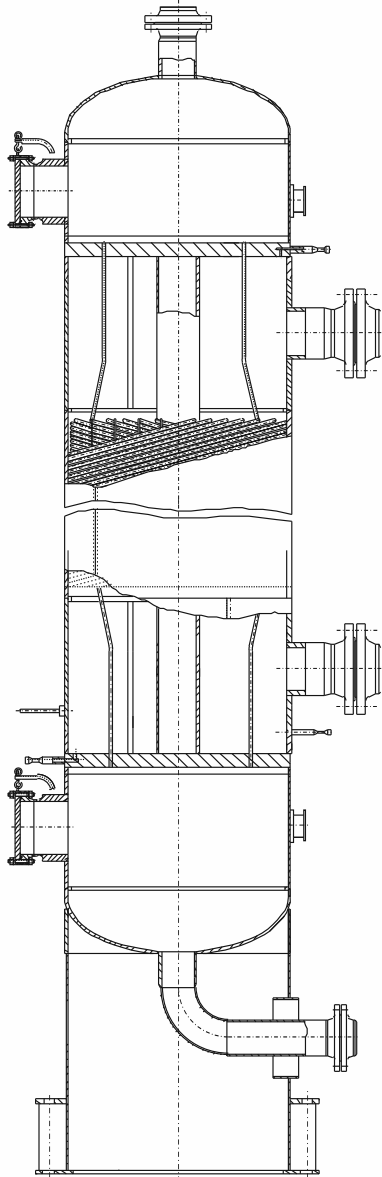

## 12 Wound Heat Exchangers

Heat exchangers with wound tubes are vertical all-welded steel shell and tube heat-exchanging units with wound tubes and hard core. They are designed for heat-exchanging between the liquid, gas or vapour-liquid media that do not require mechanical cleaning of tube and shell sides surface. These units are applied in chemical, petrochemical, gas and other related industries.

General view and components of units are shown on Figure 2.1.

Heat exchangers with wound tubes can be manufactured of the following design:

- single-flow and multi-flow as to the tube side;
- single-section and multi-section (packaged) as to arrangement.

Production capabilities of PJSC “Sumy NPO” makes it possible to fulfill complete cycle of heat exchangers manufacturing, including tests and all kinds of basic material and welding joints non-destructive testing.

Basic parameters of heat exchangers can vary in wide range and are listed in Table 2.1.

Table 2.1

Parameter	Measuring unit	Parameter value
Nominal pressure at tube and shell side	MPa	From 1.6 to 16
Working media temperature at tube and shell side	°C	From -196 to +425
Nominal area of heat exchange surface	Sq.m	from 40 to 10000
Internal diameter of unit ( $D$ )	mm	Up to 3000
Coil length ( $H_1$ )	mm	Up to 10000
Length of wound part ( $H_2$ )	mm	Up to 8000
Unit weight	Tn	Up to 100

More detailed information on the geometry of heat exchangers with wound tubes with heat exchange surface area from 40 to 1250 sq.m is specified in Industrial Standard OST 26-01-1130.

Heat exchangers with dimensions which are not specified in Industrial Standard OST 26-01-1130, if necessary can be designed by the specialists of PJSC “Sumy NPO”

Heat exchanger material is defined on material of heat-exchange tubes as the most metal-intensive part of the unit, and depending on medium temperature and corrosive power in accordance with Table 2.2.

Table 2.2

Medium	Temperature, °C	Material		Unit material design
		Grade	GOST	
Non-aggressive	From -40 to +425	Steel 10	1050-74	Carbon
	From -60 to +41	10Г2	4543-71	
	From -196 to -61	12X18H10T	5632-72	
Aggressive*	From -196 to +425			Corrosion-proof



# 13 Wound Heat Exchangers

\* Working media should not cause stress-corrosion cracking, pitting and pit corrosion of structural materials; corrosion rate should not exceed 0.05 mm per year.

For wound heat exchangers manufacturing besides of steel, specified in steel grades catalog, another materials can be used as well.

Heat exchangers with wound tubes are units of intensive action, which are characterized by high and relatively stable heat exchange coefficient, a compact design, increased rate of coolant, section coolant flow path consistency within working area.

As a rule working media running is carried out against the flow in the heat exchanger.

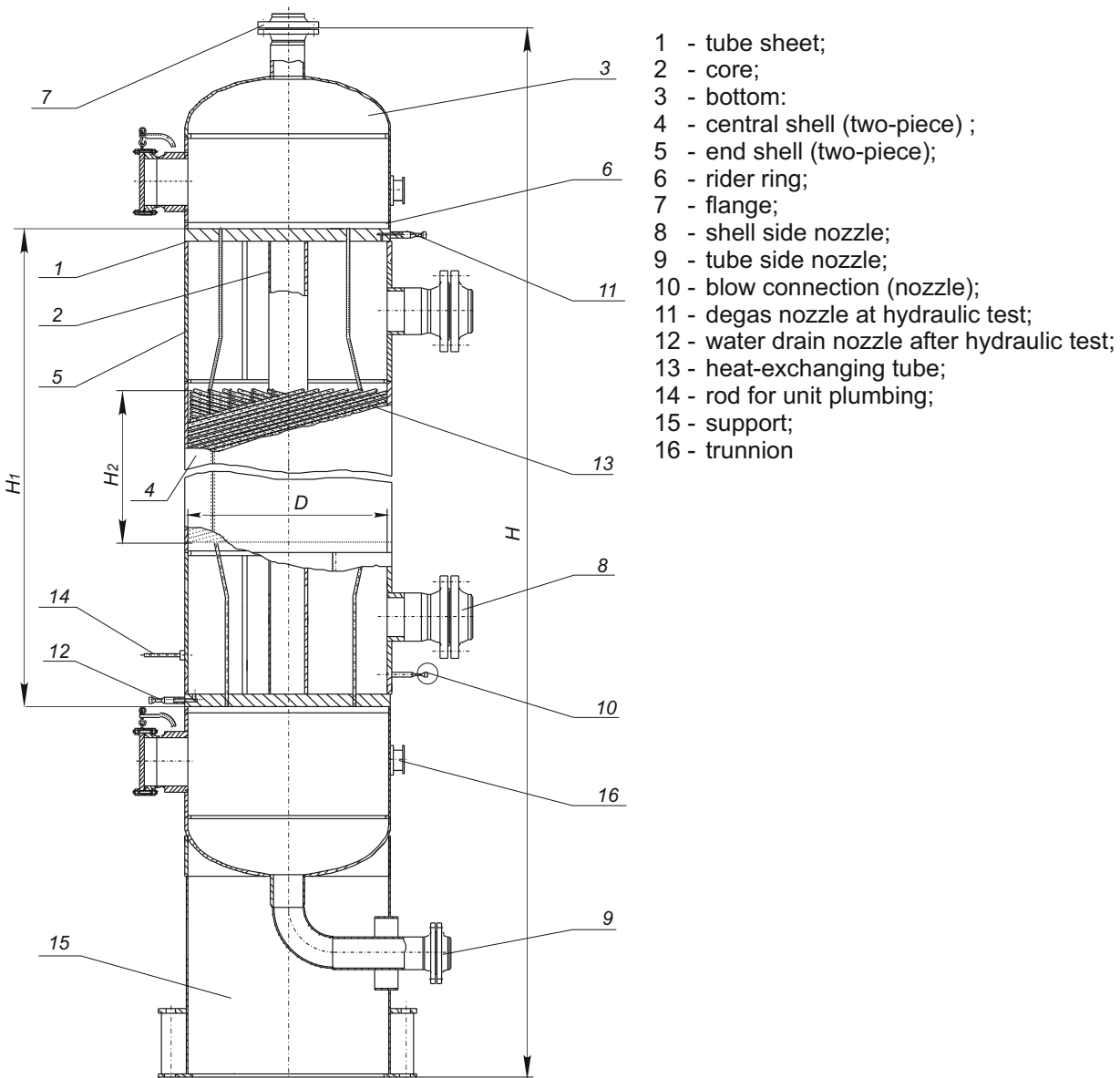

Fig. 2.1



# Heat Exchangers

Shell and Tube Heat Exchangers with Floating Head,  
Shell and Tube Heat Exchangers with “U”-Shaped Tubes  
and Tube Bundles to them  
as to Specification TU 3612-023-00220302-01



## Shell and Tube Heat Exchangers with Floating Head, Shell and Tube Heat Exchangers with “U”-Shaped Tubes

These heat exchangers are designed for heat exchanging of liquid and gaseous media in processing of oil refining, petrochemical, chemical, oil, gas and other branches of industry. They are manufactured for national and international supply.

Water or other non-toxic, non-explosive and non-fire hazard liquid with 60°C boiling temperature at pressure 0.07 MPa serves as cooling agency in coolers and condensing apparatus.

These heat exchangers can be operated in temperate and tropical climatic conditions. Climatic design “U” and “T”, item category 1 according to GOST 15150.

The heat exchangers are designed for installation in geographic areas with seismicity up to 7 points on the highest 12-point scale.

Technical requirements to materials, manufacture, acceptance, testing methods and preservation of apparatuses per SOU MPP 71.120-217:2009, GOST R 52630 and Technical Regulation of Customs Union 032/2013.

The example of heat exchanger designation when ordering:

Horizontal floating-head heat exchanger (TPG), with shell diameter 1000 mm, nominal pressure in tubes and shell 2.5 MPa, material version M1, with plain heat-transferring tubes (G) of 20 mm diameter and 6 m length, located at corners of equilateral triangles (T), 4-passes through tube side, climatic version (U), with components for heat-insulator fixing.

### Heat exchanger

**1000 TPG-2.5-M1/20ГG6-T-4-U-I**

**Specifications TU 3612-023-00220302-01**

Vertical floating-head heat exchanger (TPV), with shell diameter 325 mm, nominal pressure in tubes and shell 2.5 MPa, material version M1, with plain heat-transferring tubes (G) of 25 mm diameter and 3 m length, located at apexes of squares (K), 2-passes through tube side, climatic version (T), without components for heat-insulator fixing.

### Heat exchanger

**325 TPV-2.5-M1/25G-3-K-2-T**

**Specifications TU 3612-023-00220302-01**

Horizontal floating-head cooler (KhPG), with shell diameter 800 mm, nominal pressure in tubes 1.0 MPa and in shell 4.0 MPa, material version M3, with plain heat-transferring tubes (G) of 20 mm diameter and 6 m length, located at corners of equilateral triangles (T), 4-passes through tube side, climatic version (U), with components for heat-insulator fixing.

### Cooler

**800 KhPG-1.0-4.0-M3/20G-6-T-4-U-I**

**Specifications TU 3612-023-00220302-01**

Vertical floating-head cooler (KhPV), with shell diameter 325 mm, nominal pressure in tubes 0.6 MPa and in shell 4.0 MPa, material version M1, with plain heat-transferring tubes (G) of 25 mm diameter and 3 m length, located at apexes of squares (K), 2-passes through tube side, climatic version (T), without components for heat-insulator fixing.

### Cooler

**325 KhPV-0.6-4.0-M1/25G-3-K-2-T**

**Specifications TU 3612-023-00220302-01**

Floating-head condensing apparatus (KP), with shell diameter 600 mm, nominal pressure in tubes 1.0 MPa and in shell 2.5 MPa, material version M12, with plain heat-transferring tubes (G) of 25 mm diameter and 6 m length, located at corners of equilateral triangles (T), 6-passes through tube side, climatic version (U), with components for heat-insulator fixing.

### Condensing apparatus

**600 KP-1,0-2,5-M 12/25Г-6-T-6-Y-I**

**Specifications TU36 12-023-00220302-01**

### For heat exchangers with U-shaped tubes

Heat exchanger with U-shaped tubes (TU), with shell diameter 1400 mm, nominal pressure in tubes and shell 1.6 MPa, material version M1, with plain heat-transferring tubes (G) of 25 mm diameter and 6 m length, located at corners of equilateral triangles (T), 2-passes through tube side, climatic version (U), with components for heat-insulator fixing.

### Heat exchanger

**1400 TU-1.6-M1/25G-6-T-2-U-I**

**Specifications TU 3612-023-00220302-00**





The example of tube bundle designation when ordering (in the case of individual supply):

Tube bundle for horizontal floating-head heat exchanger (TPG), with shell diameter 1000 mm, nominal pressure in tubes and shell 2.5 MPa, material version M1, with plain heat-transferring tubes (G) of 25 mm diameter and 6 m length, located at apexes of squares (K), 4-passes through tube side, climatic version (T).

**Tube bundle**

**1000 TPG-2.5-M1/20ГG6-K-4-T**

**Specifications TU 3612-023-00220302-00**

Tube bundle for vertical floating-head cooler (KhPV), with shell diameter 500 mm, nominal pressure in tubes 1.0 MPa and in shell 2.5 MPa, material version M3, with plain heat-transferring tubes (G) of 25 mm diameter and 3 m length, located at apexes of squares (K), 2-passes through tube side, climatic version (U).

**Tube bundle**

**500KhPV-1.0-2.5-M3/25G-3-K-2-U**

**Specifications TU 3612-023-00220302-00**

Tube bundle for floating-head condensing apparatus (KP), with shell diameter 1200 mm, nominal pressure in tubes 1.0 MPa and in shell 2.5 MPa, material version M1, with plain heat-transferring tubes (G) of 25 mm diameter and 6 m length, located at corners of equilateral triangles (T), 2-passes through tube side, climatic version (U).

**Tube bundle**

**1200 KP-1.0-2.5-M1/25G-6-T-2-U**

**Specifications TU 3612-023-00220302-00**

Tube bundles for heat exchanger with “U”-shaped tubes, with shell diameter 1400 mm, nominal pressure in tubes and in shell 2.5 MPa, material version M1, with plain heat-transferring tubes (G) of 25 mm diameter and 6 m length, located at corners of equilateral triangles (T), 2-passes through tube side, climatic version (U).

**Tube bundle**

**1400 TU-2.5-M1/25G-6-T-2-U**

**Specifications TU 3612-023-00220302-00**

When choosing units, thermotechnical calculations are carried out, as well as materials, providing resistance against media corrosion effects, are selected. The heat exchangers choice is carried out by the contractor of current specifications according to the order form which is in the annex.

It is allowed to choose the heat exchangers of that design contractor which applies this type of equipment. Thereby this contractor is responsible for correct choice of the heat exchangers.

When ordering heat exchangers and tube bundles (at their individual supply), it is necessary to submit order form contained in the annex.



## Basic parameters of heat exchangers of TP, KhP, KP, TU types

Parameter	Parameter value for heat exchangers of the type			
	TP	KhP	KP	TU
Heat exchange surface, m <sup>2</sup>	10-915		84-610	12-1370
Shell diameter	Outer	325	-	325
	Inner	400*; 500*; 600*; 700*; 800; 900; 1000; 1200	600*; 700*; 800; 900; 1000; 1200	400*; 500*; 600*; 700*; 800; 900; 1000; 1200; 1400
Temperature of heat transferring media, °C	In tubes	From -30 to +450	From -20 to +400	From -30 to +450
	In casing			
Nominal pressure, MPa, in shell for heat exchangers of diameter, mm	325	4.0; 6.3	-	2.5; 4.0
	400	4.0; 6.3	-	2.5; 4.0; 6.3
	500	4.0; 6.3	-	2.5; 4.0; 6.3
	600 and 700	2.5; 4.0; 6.3; 8.0	1.0; 1.6; 2.5	1.6; 2.5; 4.0; 6.3
	800	1.6; 2.5; 4.0; 6.3; 8.0	1.0; 1.6; 2.5	1.6; 2.5; 4.0; 6.3
	900 and 1000	1.6; 2.5; 4.0; 6.3	1.0; 1.6; 2.5	1.6; 2.5; 4.0
	1200	1.6; 2.5; 4.0; 6.3	1.0; 1.6; 2.5	1.6; 2.5
	325	2.5; 4.0	-	2.5; 4.0
	400	2.5; 4.0; 6.3	-	2.5; 4.0; 6.3
	500	2.5; 4.0; 6.3; 8.0	-	2.5; 4.0; 6.3
Nominal pressure, MPa, in tubes for heat exchangers of diameter, mm	600 and 700	1.6; 2.5; 4.0; 6.3; 8.0	-	1.6; 2.5; 4.0; 6.3
	800	1.6; 2.5; 4.0; 6.3; 8.0	Up to 1.0	1.6; 2.5; 4.0; 6.3
	900 and 1000	1.6; 2.5; 4.0; 6.3	Up to 1.0	1.6; 2.5; 4.0
	1200	1.6; 2.5; 4.0; 6.3	Up to 1.0	1.6; 2.5
	1400	-	-	1.6; 2.5
	3000; 6000	-	-	1.6; 2.5
Length of heat exchanging tubes straight run, mm, for heat exchangers of diameter, mm	325; 400; 500	3000; 6000	-	3000; 6000
	600 and 700	6000	6000	6000
	800; 900; 1000; 1200	6000; 9000	6000	6000; 9000
Outer diameter and wall thickness of heat exchanging tubes (diameter and thickness)	1400	-	-	6000; 9000
	325; 400; 500	2	20x2; 25x2; 25x2.5	2
Number of passes through tubes for heat exchangers of diameter, mm	600; 700; 800; 900; 1000; 1200	2; 4	2; 4; 6	2
	1400	-	-	2
Heat exchanging tubes layout in tube sheets and partition walls	At apexes of squares and corners of equilateral triangles		At corners of equilateral triangles	

\*It is allowed to make heat exchangers shell of tubes with outer diameter 426, 530, 630, 720 mm



# Shell and Tube Heat Exchangers with Floating Head, Shell and Tube Heat Exchangers with "U"-Shaped Tubes

Heat exchanger of KhPG type

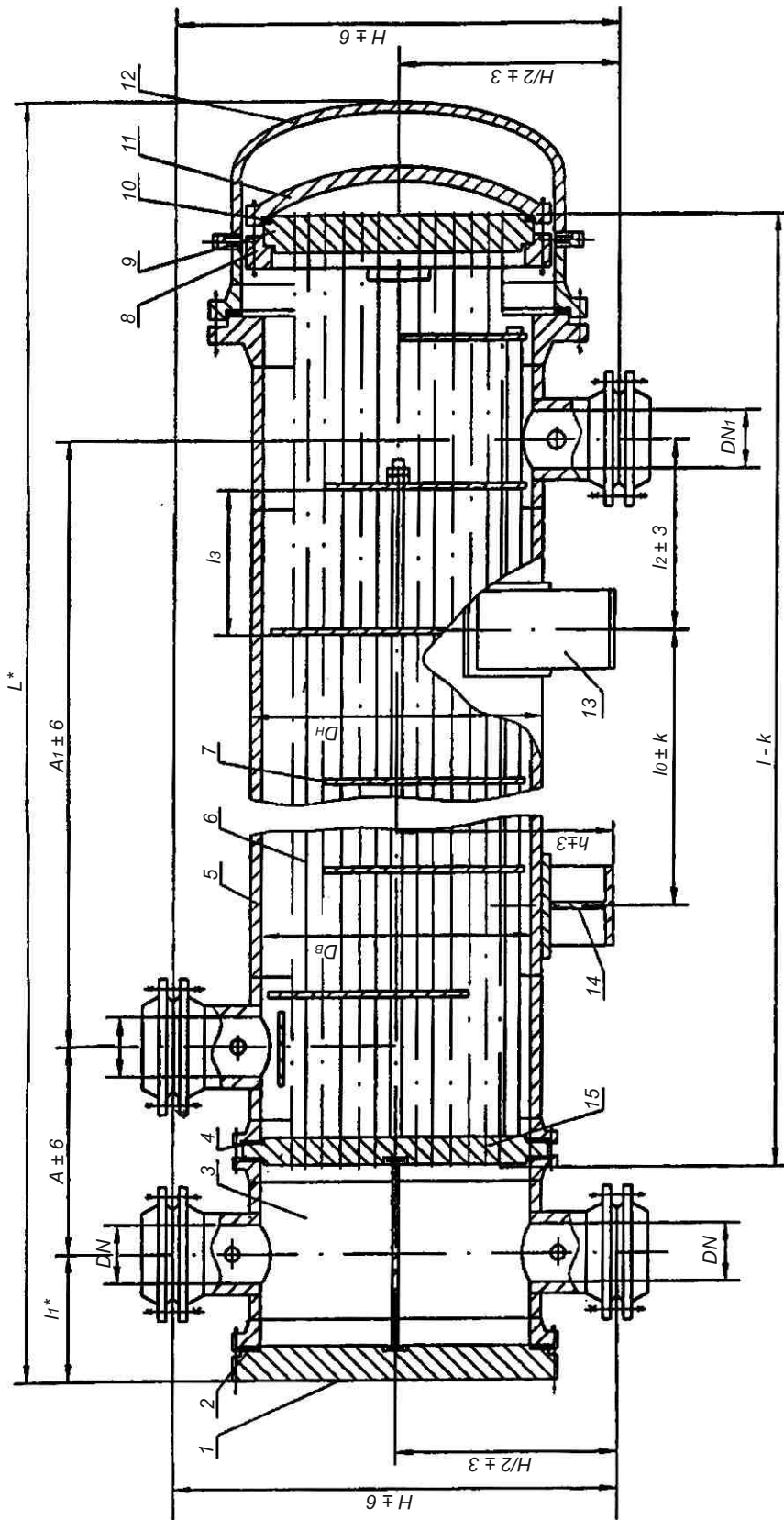

- 1 - distributing chamber cover; 2 - gasket of distributing chamber; 3 - distributing chamber; 4 - shell gasket; 5 - shell; 6 - heat exchanging tube; 7 - partition wall; 8 - semi-rings; 9 - movable tube sheet; 10 - floating head gasket; 11 - floating head cover; 12 - shell cover; 13 - movable support; 14 - fixed support; 15 - fixed tube sheet



Аппарат типа ТПГ

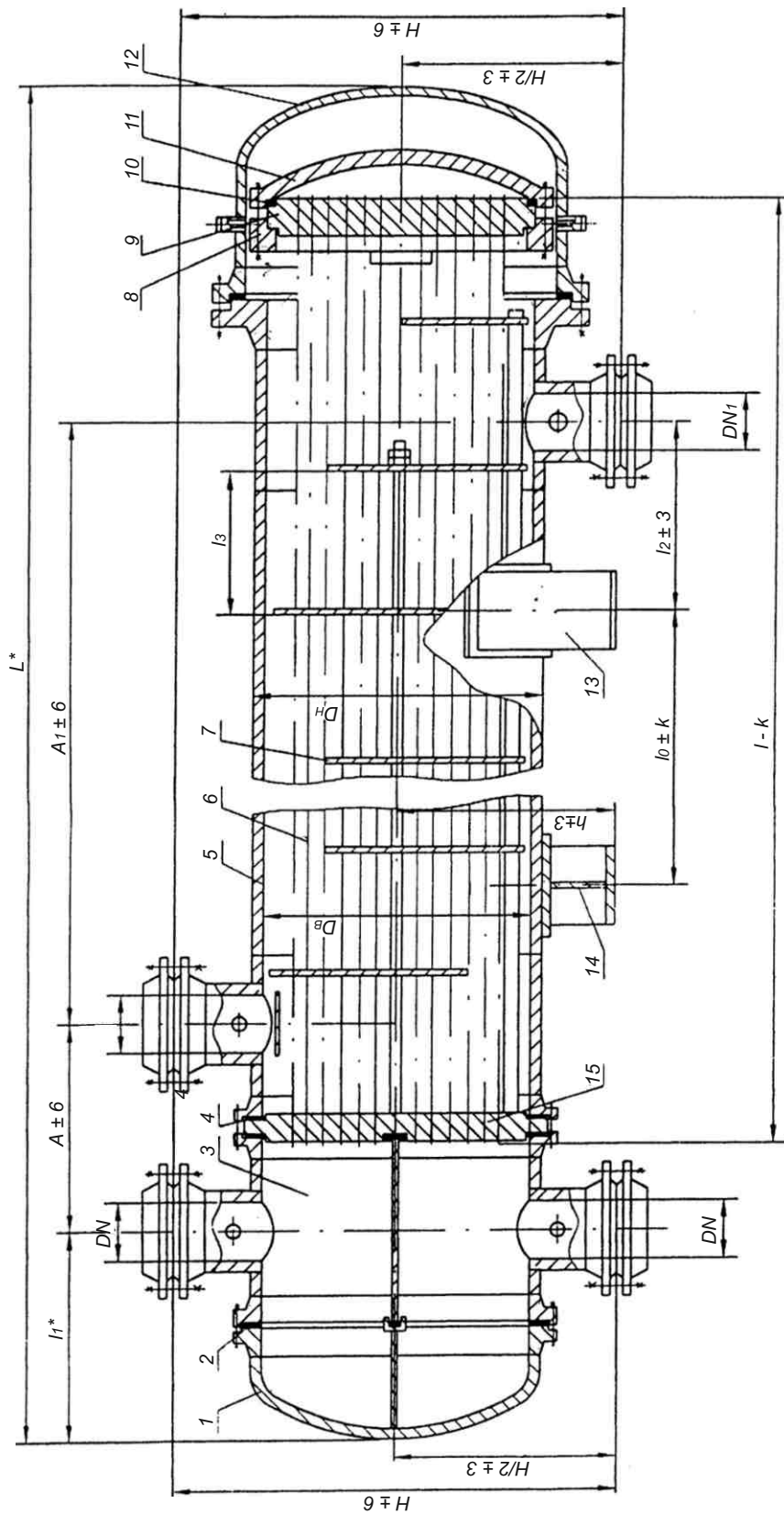

- 1 - distributing chamber cover; 2 - gasket of distributing chamber; 3 - distributing chamber; 4 - shell gasket; 5 - shell; 6 - heat exchanging tube; 7 - partition wall; 8 - semi-rings; 9 - movable tube sheet; 10 - floating head gasket; 11 - floating head cover; 12 - shell cover; 13 - movable support; 14 - fixed support; 15 - fixed tube sheet.



## Basic dimensions of TP and KhP types heat exchangers

Dimensions, mm

Shell ID $D_i$	Pressure PN, MPa, max	$L^*$	Tubes length $l$	$l_0$	Partition walls layout		$H$	DN at passes number through tubes		$DN_r$	$A$	$A_1$
					$l_3$	Number		2	4			
325**	2.5	3690	3000	1500	140	16	600	100	-	100	450	2350
		6690	6000	3000		38					5350	
400	4.0	3730	3000	1500	210	16	714	-	-	500	490	2330
		6730	6000	3000		38					5330	
400	2.5	3720	3000	1500	210	10	714	-	-	500	2250	2250
		6720	6000	3000		24					5250	
400	4.0	3750	3000	1500	210	10	714	-	-	500	2250	2250
		6750	6000	3000		24					5250	
400	6.3	3800	3000	1500	210	10	810	-	-	550	2150	2150
		6800	6000	3000		24					5150	
500	2.5	3835	3000	1500	260	8	954	150	-	150	550	2200
		6835	6000	3000		20					5200	
500	4.0	3960	3000	1500	260	8	954	150	-	150	550	2200
		6960	6000	3000		20					5200	
500	6.3	4020	3000	1500	260	8	1130	-	-	150	650	2060
		7020	6000	3000		18					5060	
500	8.0	4150	3000	1500	260	6	1130	-	-	150	800	1700
		7150	6000	3000		18					4700	
600	1.6	6900	6000	3000	320	16	1060	200	150	200	600	5100
		6950										
600	4.0	7150	6000	3000	320	14	1106	200	150	200	640	5060
		7300										
600	6.3	7300	6000	3000	320	14	1300	-	-	200	770	4760
		7380										
600	8.0	7380	6000	3000	320	14	1156	200	150	200	1000	4560
		6950										
700	1.6	7100	6000	3000	360	14	1198	200	150	200	600	5100
		7100										
700	4.0	7280	6000	3000	360	12	1262	200	150	200	720	5000
		7460										
700	6.3	7460	6000	3000	360	12	1324	-	-	200	850	4750
		7580										
700	8.0	7580	6000	3000	360	12	1396	-	-	200	1050	4450



# Shell and Tube Heat Exchangers with Floating Head, Shell and Tube Heat Exchangers with “U”-Shaped Tubes

Shell ID $D_i$	Pressure PN, MPa, max	$L^*$	Tubes length $l$	$l_0$	Partition walls layout		$H$	DN at passes number through tubes		DN <sub>r</sub>	A	A1		
					$l_3$	Number		2	4					
													Dimensions, mm	
800	1.6	7465	6000	3000	390	12	250	200	250	700	5100			
		10465	9000	6000		20					8100			
	2.5	7550	6000	3000	390	1354					12	250	750	5100
		10550	9000	6000										20
	4.0	7600	6000	3000	385	1430					12	250	890	4900
		10600	9000	6000										20
6.3	7800	6000	3000	390	1684	12	250	1250	4670					
	10800	9000	6000						20	7670				
900	1.6	8100	6000	3000	445	10	250	200	720	5000				
		11100	9000	6000						18	8000			
	2.5	7560	6000	3000		10				1374	10	250	750	4950
		10560	9000	6000										18
	4.0	7680	6000	3000		16				1492	10	250	840	7750
		10680	9000	6000										16
6.3	7840	6000	3000	16	1542	10	250	1100	4400					
	10840	9000	6000						16	7400				
1000	1.6	7615	6000	3000	500	10	300	200	750	5000				
		10615	9000	6000						16	8000			
	2.5	7720	6000	3000		10				1558	10	300	840	5000
		10720	9000	6000										16
	4.0	7870	6000	3000		8				14	10	300	1330	4800
		10870	9000	6000										16
6.3	8250	6000	3000	615	1780	8	250	820	4760					
	11250	9000	6000						14	7200				
1200	1.6	7800	6000	3000	615	8	300	250	820	4760				
		10800	9000	6000						12	7760			
	2.5	7900	6000	3000		12				1900	8	300	870	4760
		10900	9000	6000										12
	4.0	8100	6000	3000		6				12	6	250	1130	4350
		11100	9000	6000										12
6.3	8450	6000	3000	10	1900	6	250	1400	3800					
	11450	9000	6000						10	6800				

\* Recommended dimensions. They are specified at the development of detail design documentation.

\*\* Shell outer diameter (OD),  $D_o$ .

Note: Dimension 4\* for heat exchangers with shell diameter 325-700 mm is calculated inclusive of application of distributing chamber plain cover



## Heat Exchangers of TPV and KhPV Types with Tube Length 3000 mm

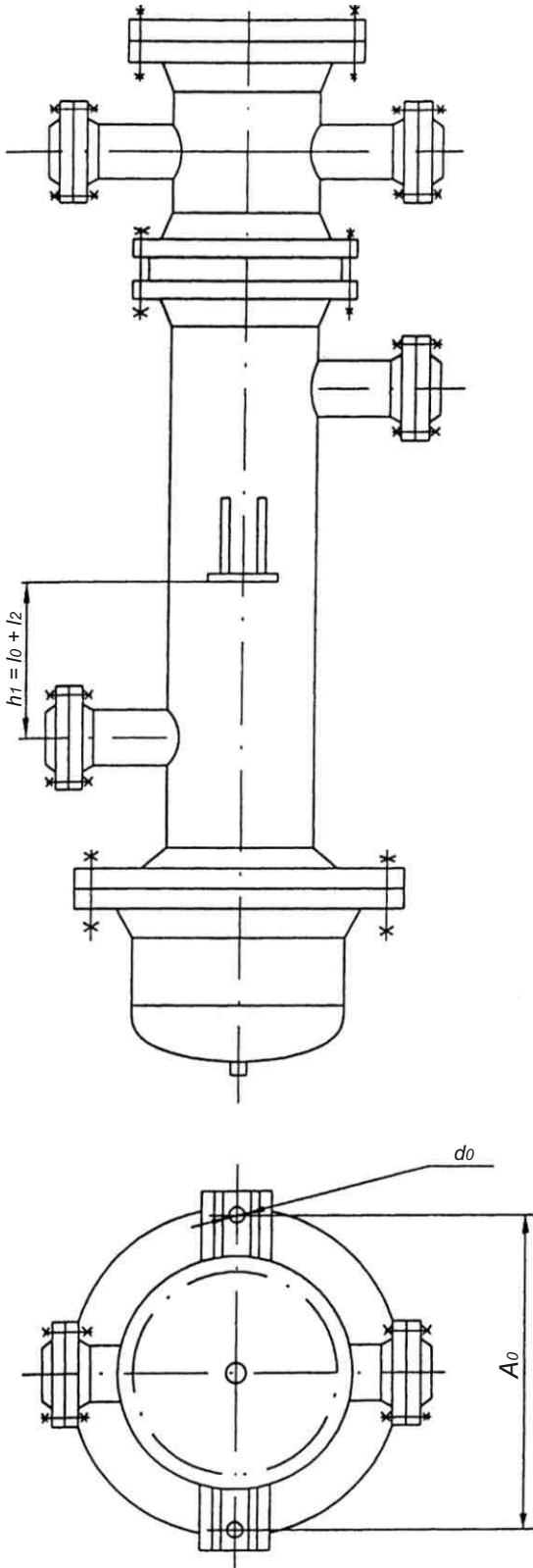

Dimensions, mm

Shell inner diameter	Supports number	$A_0$	$d_0$
325*	2	562	24
400		674	
500		830	

\* shell outer diameter

### Note:

1. Two oppositely facing midfeathers are installed at floating head on the tube bundle.
2. Heat exchangers and coolers of TPV and KhPV types should be installed indoor with temperature which is not below  $0^{\circ}\text{C}$ .
3.  $d_0$ - diameter of support foundation bolt hole
4.  $l_0$  and  $l_2$ - in accordance with figures and tables



# 23 Heat Exchangers of KP Type

Heat exchanger of KP type

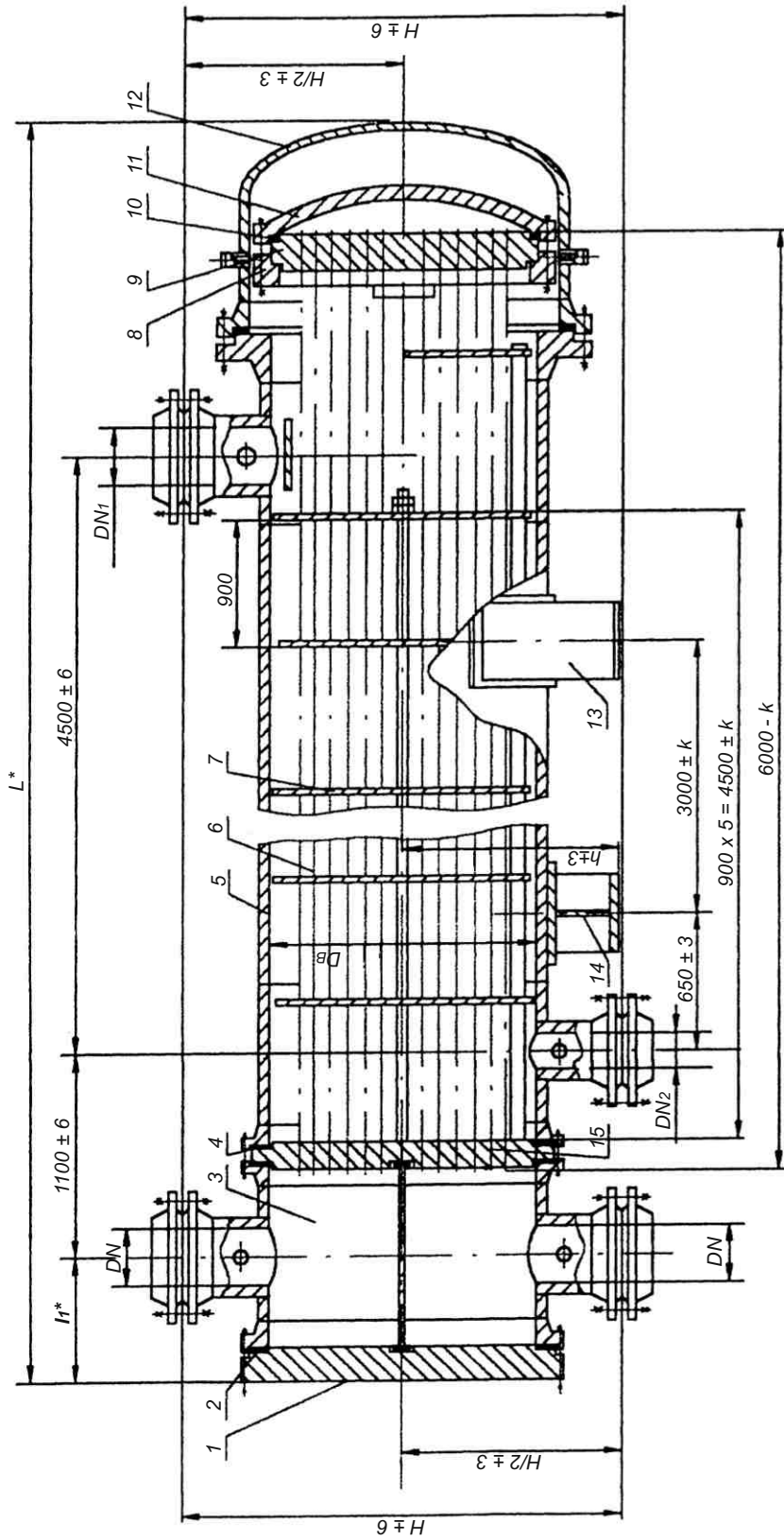

- 1 - distributing chamber cover; 2 - gasket of distributing chamber; 3 - distributing chamber; 4 - shell gasket; 5 - shell; 6 - heat exchanging tube; 7 - partition wall; 8 - semi-rings; 9 - movable tube sheet; 10 - floating head gasket; 11 - floating head cover; 12 - shell cover; 13 - movable support; 14 - fixed support; 15 - fixed tube sheet





## 24 Heat Exchangers of KP Type

### Basic dimensions of heat exchangers of KP type

Dimensions, mm

Shell ID <i>D<sub>i</sub></i>	Pressure PN, MPa, max	<i>L</i> *	<i>l<sub>1</sub></i> *	<i>H</i>	DN at passes number through tubes			<i>DN<sub>1</sub></i>	<i>DN<sub>2</sub></i>
					2	4	6		
600	1.0	6800	290	1060	200	150	100	300	100
	1.6							250	
	2.5							200	
700	1.0	6930	320	1156	200	150	100	350	100
	1.6							250	
	2.5							200	
800	1.0	7050	340	1354	250	200	150	400	150
	1.6							300	
	2.5							250	
900	1.0	7140	360	1374	250	200	150	400	150
	1.6							300	
	2.5							250	
1000	1.0	7290	410	1558	300	200	150	400	200
	1.6							300	
	2.5							300	
1200	1.0	7550	430	1780	300	250	200	500	250
	1.6							400	
	2.5							350	

\* Recommended dimensions. They are specified at the development of detail design documentation.



Heat exchanger of TU type

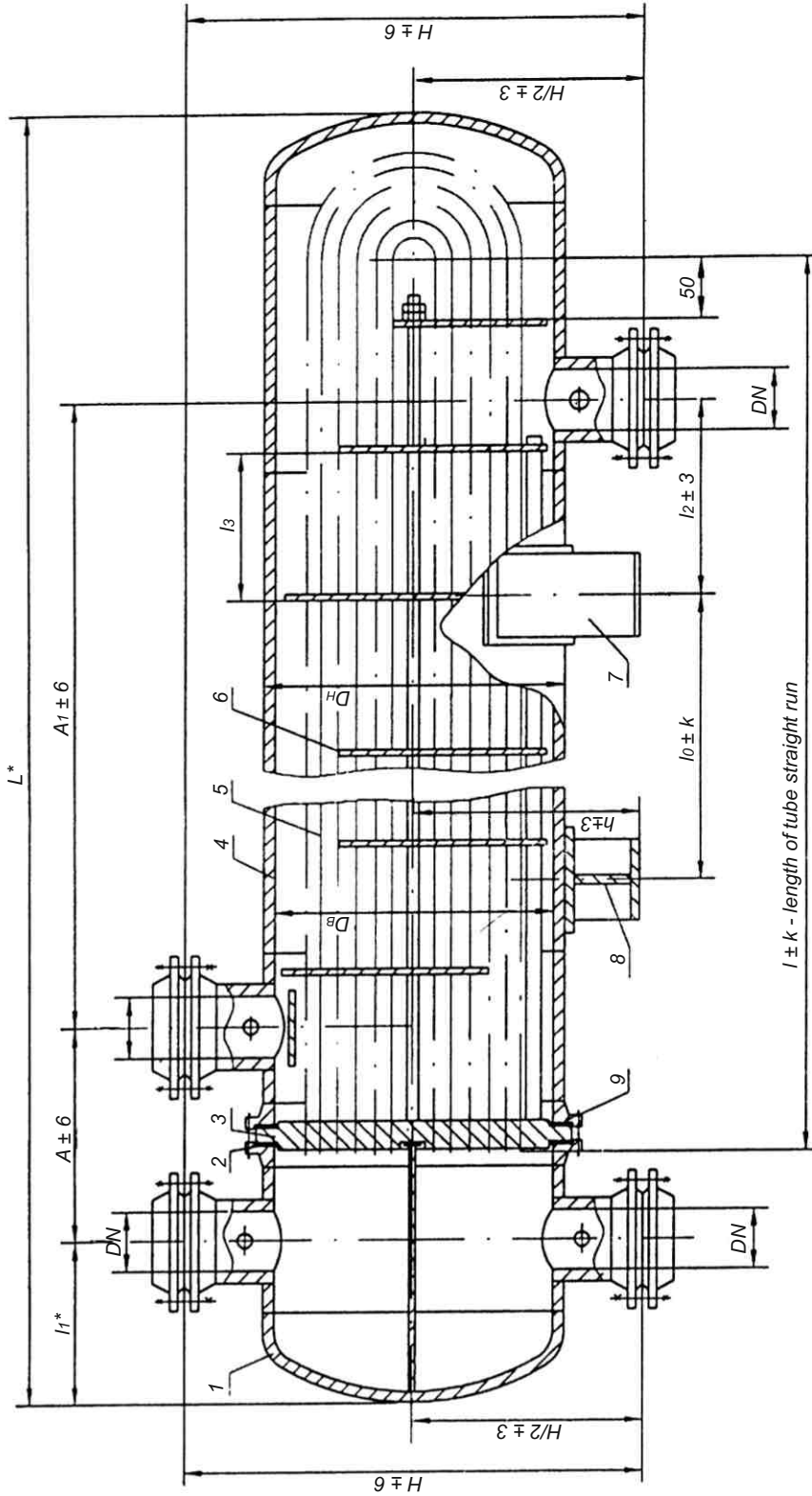

- 1 - distributing chamber; 2 - distributing chamber gasket; 3 - tube sheet; 4 - shell; 5 - heat exchanging tube; 6 - partition wall; 7 - movable support; 8 - fixed support; 9 - shell gasket



## 26 Heat Exchangers of TU Type

Basic dimensions of heat exchangers of TU type

Dimensions, mm

Shell ID, $D_i$	Pressure PN, MPa, max	$L^*$	Tubes length $l$	$l_0$	Partition walls layout		$H$	Nozzles DN	$A$	$A_1$
					$l_3$	Number				
325**	2.5	3800 6800	3000 6000	1500 3000	230	16 36	600	100	450	2500 5500
	4.0	3800 6800	3000 6000	1500 3000		16 36			490	2460 5460
400	2.5	3940 6940	3000 6000	1500 3000	270	12 26	714		500	2500 5500
	4.0	4120 7120	3000 6000	1500 3000		12 26				2500 5500
	6.3	4010 7010	3000 6000	1500 3000	280	12 26	810	2460 5460		
500	2.5	4070 7070	3000 6000	1500 3000	325	10 22	954	150	550	2500 5500
	4.0	4095 7095	3000 6000	1500 3000		10 22			2500 5500	
	6.3	4170 7170	3000 6000	1500 3000	345	10 22			650	2460 5460
600	1.6	7200	6000	3000	370	16	1060		200	600
	2.5	7240			400			640		
	4.0	7260			440			770		
	6.3	7370						1106		
700	1.6	7260	6000	3000	380	14	1156 1198 1262 1324	200	600	5400
	2.5	7300							640	
	4.0	7320							720	
	6.3	7450							850	
800	1.6	7300 10300	6000 9000	3000 6000	420	12 20	1354	250	700	5400 8400
	2.5	7315 10315	6000 9000	3000 6000		12 20			750	5360 8360
	4.0	7360 10360	6000 9000	3000 6000		12 20			910	5360 8360
	6.3	7550 10550	6000 9000	3000 6000		12 20			1430	720
900	1.6	7450 10450	6000 9000	3000 6000	445	12 18	1374	300	750	5400 8400
	2.5	7450 10450	6000 9000	3000 6000		12 18	1398		750	5400 8400
	4.0	7540 10540	6000 9000	3000 6000		12 18	1492		840	5360 8360
1000	1.6	7625 10625	6000 9000	3000 6000	500	10 16	1558	300	750	5400 8400
	2.5	7625 10625	6000 9000	3000 6000		10 16			880	5360 8360
	4.0	7660 10660	6000 9000	3000 6000		10 16			820	5400 8400
1200	1.6	7720 10720	6000 9000	3000 6000	615	8 14	1780	300	820	5400 8400
	2.5	7800 10800	6000 9000	3000 6000		8 14			870	5360 8360
1400	1.6	8055 11055	6000 9000	3000 6000	670	8 12	1980	350	1000	5200 8200
	2.5	8075 11075	6000 9000	3000 6000		8 12			5200 8200	

\* Recommended dimensions. They are specified at the development of detail design documentation.

\*\* Shell outer diameter,  $D_o$ .



Heat exchange surface as to tubes outer diameter and clear opening area as to tube and shell side for heat exchangers of TP and KhP types

Shell ID, mm	Tubes OD, mm	Number of passes through tubes	Heat exchange surface, m <sup>2</sup> , at layout of tubes in sheet				Clear opening area of one pass through tubes, m <sup>2</sup> , min, at layout of tubes in sheet						Clear opening area as to shell side, m <sup>2</sup> , at layout of tubes in sheet					
			At square apexes		At triangle corners		On square apexes		On triangle corners		In partition wall slot		Between partition walls*		In partition wall slot		Between partition walls**	
			At tubes straight run, mm				2.0		2.5		2.0		2.5		0.040		0.044	
			3000	6000	9000	6000	9000	2.0	2.5	2.0	2.5	0.040	0.044	0.045	0.042	0.042	0.042	0.042
325*	20	2	13.2	26.4	-	-	0.0070	-	-	-	-	0.010	0.024	-	-	-	-	
	25	2	10.4	20.7	-	-	0.0076	0.0069	-	-	-	0.011	0.028	-	-	-	-	
400	20	2	23.4	46.7	-	-	0.0125	-	-	-	-	0.020	0.041	-	-	-	-	
	25	2	19.3	38.6	-	-	0.0142	0.0129	-	-	-	0.020	0.043	-	-	-	-	
500	20	2	38.8	77.6	-	-	0.0207	-	-	-	-	0.032	0.064	-	-	-	-	
	25	2	31.1	62.2	-	-	0.0228	0.0207	-	-	-	0.032	0.063	-	-	-	-	
600	20	2	-	115.3	-	130.4	0.0301	-	0.0340	-	-	0.040	0.095	0.044	0.064	0.064	0.064	
	25	4	-	105.5	-	116.8	0.0131	-	0.0143	-	-	0.040	0.095	0.044	0.064	0.064	0.064	
700	20	2	-	95.1	-	106.5	0.0343	0.0311	0.0381	0.0345	-	0.045	0.090	0.042	0.064	0.064	0.064	
	25	4	-	85.7	-	92.3	0.0149	0.0135	0.0159	0.0144	-	0.045	0.090	0.042	0.064	0.064	0.064	
800	20	2	-	166.2	-	183.1	0.0436	-	0.0490	-	-	0.063	0.108	0.056	0.094	0.094	0.094	
	25	4	-	155.6	-	171.8	0.0201	-	0.0211	-	-	0.063	0.108	0.056	0.094	0.094	0.094	
900	20	2	-	129.0	-	147.4	0.0464	0.0421	0.0526	0.0477	-	0.061	0.115	0.056	0.090	0.090	0.090	
	25	4	-	118.7	-	132.4	0.0190	0.0173	0.0201	0.0182	-	0.061	0.115	0.056	0.090	0.090	0.090	
1000	20	2	-	213.7	320.5	251.7	0.0567	-	0.0661	-	-	0.077	0.136	0.073	0.094	0.094	0.094	
	25	4	-	200.8	301.3	233.6	0.0261	-	0.0281	-	-	0.077	0.136	0.073	0.094	0.094	0.094	
1200	20	2	-	176.2	264.2	200.2	0.0640	0.0581	0.0724	0.0656	-	0.073	0.135	0.059	0.098	0.098	0.098	
	25	4	-	163.0	244.0	182.3	0.0270	0.0245	0.0277	0.0251	-	0.073	0.135	0.059	0.098	0.098	0.098	
1000	20	2	-	284.1	426.2	324.1	0.0752	-	0.0856	-	-	0.097	0.120	0.088	0.129	0.129	0.129	
	25	4	-	270.5	405.8	303.0	0.0154	-	0.0380	-	-	0.097	0.120	0.088	0.129	0.129	0.129	
1000	20	2	-	224.2	336.3	258.6	0.0817	0.0741	0.0942	0.0854	-	0.073	0.169	0.093	0.129	0.129	0.129	
	25	4	-	210.1	315.1	238.8	0.0339	0.0308	0.0433	0.0393	-	0.073	0.169	0.093	0.129	0.129	0.129	
1000	20	2	-	351.2	526.8	405.4	0.0930	-	0.1071	-	-	0.123	0.200	0.111	1.140	1.140	1.140	
	25	4	-	335.4	503.0	383.6	0.0438	-	0.0492	-	-	0.123	0.200	0.111	1.140	1.140	1.140	
1000	20	2	-	285.0	427.4	325.0	0.1025	0.0929	0.1174	0.1065	-	0.119	0.216	0.112	0.150	0.150	0.150	
	25	4	-	268.9	403.4	302.4	0.0478	0.0433	0.0505	0.0458	-	0.119	0.216	0.112	0.150	0.150	0.150	
1200	20	2	-	523.4	785.1	609.7	0.1389	-	0.1610	-	-	0.161	0.309	0.154	0.197	0.197	0.197	
	25	4	-	503.0	754.5	581.8	0.0661	-	0.0768	-	-	0.161	0.309	0.154	0.197	0.197	0.197	
1200	20	2	-	429.6	644.3	499.3	0.1568	0.1422	0.1817	0.1649	-	0.161	0.311	0.144	0.185	0.185	0.185	
	25	4	-	409.8	614.7	470.1	0.0741	0.0672	0.0843	0.0757	-	0.161	0.311	0.144	0.185	0.185	0.185	

\* Shell outer diameter, mm

\*\* Clear opening is specified for row 1.



Heat - exchange surface as to tubes outer diameter  
and clear opening area as to tube and shell side for heat exchangers of KP type

Shell ID, mm	Tubes OD, mm	Pressure in shell, PN, MPa, max	Heat exchange surface, m <sup>2</sup> , at number of passes through tubes			Clear opening area of one pass through tubes, m <sup>2</sup> , min, at tube thickness, mm						
			2	4	6	2.0						
						At number of passes through tubes						
			2	4	6	2	4	6	2	4	6	
600	20	1.0	126.2	112.7	107.4	0.024	0.012	0.009	-	-	-	-
		1.6;2.5	130.4	116.8	111.5	0.024	0.014	0.008	-	-	-	-
		1.0	102.2	88.1	83.4	0.035	0.013	0.008	0.032	0.012	0.007	0.007
700	25	1.6;2.5	106.4	92.3	87.6	0.038	0.016	0.010	0.035	0.014	0.009	0.009
		1.0	182.7	166.9	157.1	0.046	0.018	0.013	-	-	-	-
		1.6;2.5	187.6	171.8	162.0	0.049	0.021	0.013	-	-	-	-
800	25	1.0	141.8	125.8	120.1	0.048	0.020	0.010	0.044	0.019	0.009	0.009
		1.6;2.5	147.4	132.4	125.8	0.153	0.020	0.014	0.048	0.018	0.013	0.013
		1.0	240.0	221.2	212.1	0.060	0.027	0.017	-	-	-	-
900	20	1.6	246.1	228.0	218.2	0.063	0.028	0.020	-	-	-	-
		2.5	251.7	233.6	223.8	0.066	0.028	0.018	-	-	-	-
		1.0	194.5	174.7	169.1	0.068	0.30	0.017	0.062	0.028	0.015	0.015
1000	25	1.6;2.5	200.2	180.4	174.7	0.072	0.30	0.021	0.066	0.028	0.019	0.019
		1.0	317.6	296.5	288.3	0.082	0.038	0.022	-	-	-	-
		1.6;2.5	324.0	302.9	294.7	0.085	0.038	0.026	-	-	-	-
1200	20	1.0	252.9	233.1	224.7	0.090	0.039	0.024	0.082	0.035	0.022	0.022
		1.6;2.5	258.6	238.8	228.4	0.094	0.043	0.027	0.085	0.039	0.025	0.025
		1.0	399.0	377.2	365.9	0.104	0.049	0.030	-	-	-	-
1200	25	1.6;2.5	405.4	382.8	372.3	0.107	0.049	0.033	-	-	-	-
		1.0; 1.6; 2.5	325	302.4	293.9	0.117	0.051	0.034	0.106	0.046	0.030	0.030
		1.0	592.7	564.8	552.0	0.164	0.068	0.044	-	-	-	-
1200	20	1.6	601.7	573.5	561.1	0.164	0.073	0.048	-	-	-	-
		2.5	609.7	580.3	569.0	0.161	0.076	0.048	-	-	-	-
		1.0	481.8	452.6	441.3	0.151	0.075	0.043	0.137	0.068	0.039	0.039
1200	25	1.6	491.3	462.0	450.7	0.176	0.082	0.050	0.160	0.074	0.045	0.045
		2.5	499.3	470.0	458.8	0.182	0.083	0.055	0.165	0.075	0.050	0.050



Heat-exchange surface as to tubes outer diameter  
and clear opening area as to tube and shell side for heat exchangers of TU type

Shell ID, mm	Tubes OD, mm	Heat exchange surface, m <sup>2</sup> , at length of tube straight run, mm			Clear opening area of one pass through tubes, m <sup>2</sup> , min, at tube wall thickness, mm		Clear opening area as to shell side, m <sup>2</sup>	
		3000	6000	9000	2.0	2.5	In partition wall slot	Between partition walls**
325*	20	16.3	32.2	-	0.0084	-	0.0101	0.0151
	25	12.1	23.9	-	0.0087	0.0079	0.0129	0.0150
400	20	31.4	61.6	-	0.0161	-	0.0178	0.0280
	25	23.0	45.2	-	0.0163	0.0148	0.0255	0.0250
500	20	52.0	101.3	-	0.0263	-	0.0265	0.0400
	25	41.7	81.2	-	0.0291	0.0264	0.0269	0.0438
600	20	-	144.4	-	0.0374	-	0.0414	0.0603
	25	-	115.5	-	0.0412	0.0374	0.0397	0.0586
700	20	-	202.0	-	0.0521	-	0.0531	0.0720
	25	-	160.0	-	0.0568	0.0515	0.0801	0.0810
800	20	-	274.5	406.4	0.0703	-	0.0693	0.0880
	25	-	212.5	314.7	0.0751	0.0681	0.0772	0.0900
900	20	-	353.7	522.9	0.0902	-	0.0849	0.1032
	25	-	286.9	423.9	0.01007	0.0914	0.0875	0.1183
1000	20	-	450.0	664.0	0.1141	-	0.1049	0.1300
	25	-	354.2	522.8	0.1239	0.1124	0.1063	0.1375
1200	20	-	662.4	974.4	0.1664	-	0.1496	0.2091
	25	-	554.5	800.7	0.1883	0.1708	0.1385	0.1999
1400	20	-	934.1	1369.7	0.2323	-	0.1981	0.2546
	25	-	758.8	1112.5	0.2600	0.2358	0.1953	0.2513

\* Shell outer diameter, mm

\*\* Clear opening is specified for row 1.

Heat exchange surface is shown excluding tube sheets thickness.



## Materials for TP, KhP, KP, TU types heat exchangers assembly units and main components manufacturing

Heat exchanger type	Heat exchanger material design	Material						
		Shell and cover	Distributing chamber and cover	Heat exchanging tubes	Tube sheet	Partition wall	Shell gaskets	Distributing chamber gaskets
TP, TU, KhP, KP	M1	Steel Ct3cn as to GOST 380, GOST 14637 tubes - steel 20 as to GOST 1050, GOST 8731, gr. B or Steel Ct3cn as to GOST 380, GOST 10706, gr.B	Steel Ct3cn, Ct3nc <sup>1)</sup> as to GOST 380, GOST 14637 steel 09Г2C as to GOST 5520 tubes - steel 20 as to GOST 1050, GOST 8731, gr. B or Steel Ct3cn as to GOST 380, GOST 10706, gr.B	Steel 10 and 20 as to GOST 1050, GOST 550 gr.A, GOST 8733 <sup>2)</sup> gr.B and electric welded tubes as to duly approved technical documentation <sup>3)</sup>	Steel 09Г2C as to GOST 5520 and GOST 19281, GOST 8479 gr. IV-KП.245	Cт 3cn as to GOST 380, GOST 14637	Asbestos-free gasket materials of "Frenzleit" Company	Aluminium of grade АД as to GOST 21631. Brass Л63 as to GOST 2208. Steel 08 as to GOST 1577, GOST 9045 BF. Gr. Ш
		See material design M1	See material design M1	Brass ЛАМлу 77-2-0.5 GOST 15527, GOST 21646	Steel 09Г2C as to GOST 5520 and GOST 19281, GOST 8479 ЛЮ 62-1 or Л63 brass surfacing as to GOST 15527, GOST 931	See material design M1	Asbestos-free gasket materials of "Frenzleit" Company	Brass Л63 As to GOST 2208
KhP, KP	M12	See material design M1	Steel 08X22H6Г as to GOST 5632, GOST 9941, steel 12X18H10T3 as to GOST 5632, GOST 9941	Steel 09Г2C as to GOST 5520 and GOST 19281, GOST 8479	See material design M1	See material design M1	See material design M1	Steel 08X18H10 As to GOST 7350 Or GOST 5949
TP, TU, KhP, KP	M13	See material design M1	Steel 12X18H10T, 18X18H10T as to GOST 5632, GOST 9941	Steel 12X18H10T, 08X18H10T as to GOST 5632, GOST 7350, gr. M26, GOST 25054, gr. IV and duly approved technical documentation	See material design M1	See material design M1	See material design M1	Steel 08X18H10 As to GOST 7350 Or GOST 5949

1) Apply for KhP, KP types only.

2) Apply for TP, TU types.

3) Apply by the agreement with Customer only.

4) Apply by the agreement with Customer at nominal pressure up to 4.0 MPa and temperature up to 4000°C.

Notes:

1. It is allowed to make assembly units of another grades materials, described in the Industrial Standard OST 26-291. These materials should be of the same technical properties and corrosion resistance as those which are listed in the table.
2. Materials limitation and specifications should comply with the Industrial Standard OST 26-291.
3. Gasket material should be selected considering working medium, parameters and corrosivity.
4. It is allowed to use spiral-wound gaskets as to OST 265.240.453.

Shell inner diameter	Pressure PN, MPa, max	Tubes 20x2, length						Tubes 25x2, length						Tubes 25x2.5, length						
		3000		6000		9000		3000		6000		9000		3000		6000		9000		
		Steel	Brass	Steel	Brass	Steel	Brass	Steel	Brass	Steel	Brass	Steel	Brass	Steel	Brass	Steel	Brass	Steel	Brass	
325*	2.5	950	1000	1400	1470	1470	920	960	1330	1390	1390	950	950	1400						
	4.0	1150	1180	1600	1670	1670	1070	1150	1530	1560	1560	1150	1150	1600						
	2.5	1390	1420	2050	2150	2150	1340	1370	1940	2050	2050	1400	1400	2070						
	4.0	1690	1740	2340	2430	2430	1640	1680	2240	2300	2300	1700	1700	2360						
	6.3	2190	-	2880	-	-	2140	-	2770	-	-	2200	2200	2900						
	2.5	2080	2140	3030	3140	3140	1970	2000	2800	2880	2880	2070	2070	3000						
500	4.0	2510	2600	3680	3790	3790	2410	2450	3450	3530	3530	2500	2500	3650						
	6.3	3310	-	4480	-	-	3200	-	4270	-	-	3300	3300	4450						
	8.0	4270	-	5680	-	-	4160	-	5500	-	-	-	-	5650						
	Pressure PN, MPa, max	6000		9000		9000		6000		9000		6000		9000		6000		9000		
600	2 passes	Steel		Brass		Steel		Brass		Steel		Brass		Steel		Brass		Steel		
		1.6	3940	4100	-	-	3700	3840	-	-	3990	-	-	3990	-	-	-	-	-	-
		2.5	4180	4300	-	-	3880	4010	-	-	4200	-	-	4200	-	-	-	-	-	-
		4.0	5050	5210	-	-	4750	4880	-	-	5100	-	-	5100	-	-	-	-	-	-
		6.3	6720	-	-	-	6500	-	-	-	6750	-	-	6750	-	-	-	-	-	-
		8.0	8100	-	-	-	7830	-	-	-	8150	-	-	8150	-	-	-	-	-	-
	4 passes	Steel		Brass		Steel		Brass		Steel		Brass		Steel		Brass		Steel		
		1.6	3820	3960	-	-	3600	3720	-	-	3920	-	-	3920	-	-	-	-	-	-
		2.5	4100	4170	-	-	3780	3900	-	-	4100	-	-	4100	-	-	-	-	-	-
		4.0	4880	5020	-	-	4700	4820	-	-	5000	-	-	5000	-	-	-	-	-	-
		6.3	6480	-	-	-	6400	-	-	-	6620	-	-	6620	-	-	-	-	-	-
		8.0	7980	-	-	-	7730	-	-	-	8020	-	-	8020	-	-	-	-	-	-
700	2 passes	Steel		Brass		Steel		Brass		Steel		Brass		Steel		Brass		Steel		
		1.6	5550	5780	-	-	5100	5280	-	-	5550	-	-	5550	-	-	-	-	-	
		2.5	4100	6410	-	-	5730	5910	-	-	6180	-	-	6180	-	-	-	-	-	-
		4.0	4880	7560	-	-	6880	7060	-	-	7330	-	-	7330	-	-	-	-	-	-
		6.3	6480	-	-	-	9300	-	-	-	9720	-	-	9720	-	-	-	-	-	-
		8.0	7980	-	-	-	11870	-	-	-	12290	-	-	12290	-	-	-	-	-	-
	4 passes	Steel		Brass		Steel		Brass		Steel		Brass		Steel		Brass		Steel		
		1.6	5400	5600	-	-	5000	5170	-	-	5400	-	-	5400	-	-	-	-	-	-
		2.5	6050	6250	-	-	5650	5820	-	-	6050	-	-	6050	-	-	-	-	-	-
		4.0	7160	7360	-	-	6750	6920	-	-	7150	-	-	7150	-	-	-	-	-	-
		6.3	9570	-	-	-	9180	-	-	-	9580	-	-	9580	-	-	-	-	-	-
		8.0	12110	-	-	-	11720	-	-	-	12120	-	-	12120	-	-	-	-	-	-
800	2 passes	Steel		Brass		Steel		Brass		Steel		Brass		Steel		Brass		Steel		
		1.6	7000	7400	9350	9340	6790	7040	8750	9080	7100	9550								
		2.5	7500	7900	10100	10650	7150	7450	9300	9680	7600	10270								
		4.0	9150	9450	11700	12200	9100	9350	10990	11370	9250	18870								
		6.3	11590	-	14580	-	11120	-	13870	-	14750	-	-	14750	-	-	-	-	-	-
		8.0	16650	-	20200	-	16120	-	19490	-	20370	-	-	20370	-	-	-	-	-	-





Continuation sheet

Dimensions, mm

Shell inner diameter	Pressure PN, MPa, max	Tubes 20x2, length						Tubes 25x2, length						Tubes 25x2.5, length			
		6000		9000		9000		6000		9000		9000		6000	9000		
		Steel	Brass	Steel	Brass	Steel	Brass	Steel	Brass	Steel	Brass	Steel	Brass	Steel	Steel		
800	4 passes	1.6	6850	7150	9150	9570	6620	6860	8550	8800	6900	9300					
		2.5	7400	7850	9950	10370	7050	7350	9150	9400	7450	10100					
		4.0	9100	9360	11500	11920	8930	9170	10740	11090	9100	11650					
		6.3	11440	-	14350	-	109200	-	13600	-	-	11500	14550				
		8.0	16500	-	20000	-	15950	-	19240	-	-	16500	20060				
	2 passes	1.6	8500	11500	8890	12090	7710	10290	8030	10760	8450	11420					
		2.5	9670	12950	10060	13540	8880	11740	9200	12210	9620	12870					
		4.0	11730	15110	12120	15700	10880	13900	11200	14340	11610	15030					
		6.3	15800	-	16190	-	15030	-	15350	-	15750	19470					
		4 passes	1.6	8350	11260	8750	11820	7590	10070	7890	10520	8290	11140				
900	2 passes	2.5	9540	12720	9920	13820	8760	11520	9060	11970	9460	12590					
		4.0	11500	14860	11880	15420	10730	13660	11030	14110	11420	14720					
		6.3	15620	-	16000	-	14850	-	15160	-	15550	19140					
		4 passes	1.6	10700	11200	14770	15500	9950	10550	13480	14250	10780	14900				
		2.5	11370	11850	15470	16200	10500	11100	14180	14900	11450	15600					
	4 passes	4.0	13920	14400	18100	18900	13050	13650	16900	17650	14000	18200					
		6.3	18900	-	24250	-	18040	-	23050	-	18980	24400					
		1.6	10480	10950	14420	15100	9700	10300	13150	13850	10500	14500					
		2.5	11150	11600	15120	15800	10300	10850	13860	14550	11300	15160					
		4.0	13690	14150	17750	18550	12850	13450	16600	17300	13750	17800					
1000	2 passes	6.3	18670	-	23900	-	17800	-	22700	-	18690	23960					
		4 passes	1.6	14720	15450	20040	21140	13470	14080	18500	19400	14900	20370				
		2.5	16690	17600	21900	23000	15550	16200	20100	21100	16900	22230					
		4.0	21200	21930	26680	27800	19970	20800	25100	26000	21400	27000					
		6.3	28300	-	35500	-	27100	-	33700	-	28500	35830					
	4 passes	1.6	14560	15270	19600	20700	131180	13900	18100	18970	14640	19830					
		2.5	16280	17100	21500	22600	15290	15870	19900	20770	16500	21700					
		4.0	20900	21600	26300	27400	19680	20500	24800	25670	21100	26700					
		6.3	28000	-	35060	-	26800	-	33300	-	28220	35290					
		4 passes	1.6	14560	15270	19600	20700	131180	13900	18100	18970	14640	19830				

\* shell outer diameter



Weight of TP type heat exchangers at tube holes layout at triangles corners

Shell inner diameter	Pressure PN, MPa, max	Dimensions, mm											
		Tubes 20x2, length				Tubes 25x2, length				Tubes 25x2.5, length			
		6000		9000		6000		9000		6000		9000	
		Steel	Brass	Steel	Brass	Steel	Brass	Steel	Brass	Steel	Brass	Steel	Brass
Weight, kg													
600		<b>2 passes</b>											
	1.6	4450	4650	-	-	4170	4350	-	-	4500	4500	-	-
	2.5	4550	4750	-	-	4250	4400	-	-	4600	4600	-	-
	4.0	5450	5650	-	-	5150	5300	-	-	5500	5500	-	-
	6.3	6900	-	-	-	6600	-	-	-	6960	6960	-	-
	8.0	9450	-	-	-	9100	-	-	-	9500	9500	-	-
		<b>4 passes</b>											
	1.6	4280	4430	-	-	4020	4160	-	-	4280	4280	-	-
	2.5	4380	4530	-	-	4110	4200	-	-	4380	4380	-	-
	4.0	5280	5430	-	-	4990	5100	-	-	5280	5280	-	-
6.3	6700	-	-	-	6430	-	-	-	6740	6740	-	-	
8.0	9280	-	-	-	8950	-	-	-	9280	9280	-	-	
700		<b>2 passes</b>											
	1.6	5810	4430	-	-	5390	5600	-	-	5900	5900	-	-
	2.5	6440	4530	-	-	6020	6230	-	-	6530	6530	-	-
	4.0	7590	5430	-	-	7170	7380	-	-	7680	7680	-	-
	6.3	10000	-	-	-	9590	-	-	-	10070	10070	-	-
	8.0	12570	-	-	-	12160	-	-	-	12640	12640	-	-
		<b>4 passes</b>											
	1.6	5620	5840	-	-	5150	5330	-	-	5580	5580	-	-
	2.5	6270	6490	-	-	5800	5980	-	-	6230	6230	-	-
	4.0	7380	7600	-	-	6900	7080	-	-	7330	7330	-	-
6.3	9790	-	-	-	9330	-	-	-	9760	9760	-	-	
8.0	12330	-	-	-	11870	-	-	-	12300	12300	-	-	
800		<b>2 passes</b>											
	1.6	7500	7950	10150	10850	6900	7300	9250	9700	7530	7530	10200	
	2.5	8450	8800	10850	11500	7820	8100	9900	10300	8480	8480	10900	
	4.0	9870	10220	12550	13500	9250	9530	11600	12120	9900	9900	12600	
	6.3	12200	-	15450	-	11570	-	14500	-	12230	12230	15500	
	8.0	17100	-	20800	-	16470	-	19860	-	17130	17130	20850	
		<b>4 passes</b>											
	1.6	7280	7700	9800	10450	6700	7150	8900	9300	7240	7240	9800	
	2.5	8230	8560	10600	11100	7600	7850	9550	9900	8190	8190	10460	
	4.0	9650	9980	12250	13100	9000	9280	11240	11700	9600	9600	12200	
6.3	11980	-	15200	-	11300	-	14140	-	11940	11940	15100		
8.0	16880	-	20600	-	16230	-	19500	-	16840	16840	20400		



Shell inner diameter	Pressure PN, MPa, max	Dimensions, mm												Continuation sheet			
		Tubes, 20x2, length				Tubes 25x2, length				Tubes 25x2.5, length							
		6000		9000		6000		9000		6000		9000				6000	9000
		Steel	Brass	Steel	Brass	Steel	Brass	Steel	Brass	Steel	Brass	Steel	Brass			Steel	Brass
900	2 passes	1.6	9060	12340	9500	13010	8220	11060	8590	11600	9080	12360					
		2.5	10230	13790	10670	14460	9390	12510	9760	13050	10250	13810					
		4.0	12290	15950	12730	16620	11390	14670	11760	15180	12240	15970					
		6.3	16360	-	16800	-	15540	-	15910	-	-	16380	20410				
		1.6	8820	11970	9270	12600	8020	10710	8360	11220	8820	11930					
		2.5	10010	13430	10440	14060	9190	12160	9530	12670	9990	13380					
	4 passes	4.0	11970	15570	12400	16200	11160	14300	11500	14810	11950	15510					
		6.3	16090	-	16520	-	15280	-	15630	-	16080	19930					
		1.6	11550	12100	15900	16750	10530	11150	14350	15150	11600	15950					
		2.5	12000	12650	16650	17490	11100	11750	15060	15850	12050	16680					
		4.0	14650	15200	19350	20200	13650	14300	17780	18600	14700	19400					
		6.3	19550	-	24800	-	18530	-	23950	-	19600	24850					
1000	2 passes	1.6	11230	11750	15420	16250	10190	10800	13850	14600	11200	15350					
		2.5	11750	12300	16170	16970	10760	11380	14560	15300	11750	16060					
		4.0	14350	14850	18870	19680	13300	13950	17300	18050	14350	18800					
		6.3	19230	-	24320	-	18190	-	23450	-	19200	24200					
		1.6	16700	17550	23300	24600	15150	15900	21160	22200	16800	23650					
		2.5	18600	19450	24900	26200	17040	17750	22750	23800	18700	25250					
	4 passes	4.0	20600	21450	28500	29800	19350	20370	27150	28200	20800	28850					
		6.3	28950	-	36050	-	27490	-	33900	-	29150	36400					
		1.6	16350	17200	22690	23400	14800	15440	20530	21500	16290	22880					
		2.5	18200	19000	24300	25500	16620	17290	22100	23100	18190	24480					
		4.0	20190	21000	27890	29250	18930	19900	26500	27600	20300	28080					
		6.3	28550	-	35500	-	27070	-	33270	-	28600	35600					
1200	2 passes	1.6	16700	17550	23300	24600	15150	15900	21160	22200	16800	23650					
		2.5	18600	19450	24900	26200	17040	17750	22750	23800	18700	25250					
		4.0	20600	21450	28500	29800	19350	20370	27150	28200	20800	28850					
		6.3	28950	-	36050	-	27490	-	33900	-	29150	36400					
		1.6	16350	17200	22690	23400	14800	15440	20530	21500	16290	22880					
		2.5	18200	19000	24300	25500	16620	17290	22100	23100	18190	24480					
	4 passes	4.0	20190	21000	27890	29250	18930	19900	26500	27600	20300	28080					
		6.3	28550	-	35500	-	27070	-	33270	-	28600	35600					



Weight of KhP type heat exchangers at tube holes layout at squares apexes

Dimensions, mm

Shell inner diameter	Pressure PN, MPa, max	Tubes 20x2, length						Tubes 25x2, length						Tubes 25x2.5, length						
		3000			6000			3000			6000			3000			6000			
		Steel	Brass	Steel	Brass	Steel	Brass	Steel	Brass	Steel	Brass	Steel	Brass	Steel	Brass	Steel	Brass	Steel	Brass	
325*	4.0	1030	1070	1520	1570	1000	1050	1450	1490	1030	1030	1520	1570	1000	1050	1450	1490	1030	1030	
	6.3	1360	-	-	-	-	1150	1530	1560	-	-	-	-	-	1150	1530	1560	1150	1600	
	4.0	1640	1700	2250	2350	1590	1640	2150	2210	1650	1650	2250	2350	1590	1640	2150	2210	1650	2270	
	6.3	2000	-	2750	-	1950	-	2600	-	2010	2010	2750	-	1950	-	2600	-	2010	2770	
	4.0	2400	2460	3430	3540	2300	2350	3300	3380	2390	2390	3430	3540	2300	2350	3300	3380	2390	3400	
	6.3	3000	-	4180	-	2890	-	3980	-	2990	2990	4180	-	2890	-	3980	-	2990	4150	
Shell inner diameter	Pressure PN, MPa, max	Tubes 20x2, length						Tubes 25x2, length						Tubes 25x2.5, length						
		6000			9000			6000			9000			6000			9000			
		Steel	Brass	Steel	Brass	Steel	Brass	Steel	Brass	Steel	Brass	Steel	Brass	Steel	Brass	Steel	Brass	Steel	Brass	
600	2.5	4150	4310	-	-	3880	4010	-	-	4200	4200	-	-	3880	4010	-	-	4200	-	
	4.0	4800	4960	-	-	4500	4630	-	-	4850	4850	-	-	4500	4630	-	-	4850	-	
	6.3	6260	-	-	-	6000	-	-	-	6290	6290	-	-	6000	-	-	-	6290	-	
	2 хода																			
	2.5	4050	4190	-	-	3780	3900	-	-	4070	4070	-	-	3780	3900	-	-	4070	-	
	4.0	4680	4820	-	-	4400	4520	-	-	4720	4720	-	-	4400	4520	-	-	4720	-	
6.3	6140	-	-	-	5900	-	-	-	6160	6160	-	-	5900	-	-	-	6160	-		
4 хода																				
700	2.5	6030	6260	-	-	5580	5760	-	-	6030	6030	-	-	5580	5760	-	-	6030	-	
	4.0	6930	7160	-	-	6480	6660	-	-	6930	6930	-	-	6480	6660	-	-	6930	-	
	6.3	9030	-	-	-	8590	-	-	-	9010	9010	-	-	8590	-	-	-	9010	-	
	2 хода																			
	2.5	5870	6070	-	-	5470	5640	-	-	5870	5870	-	-	5470	5640	-	-	5870	-	
	4.0	6700	6900	-	-	6290	6460	-	-	6690	6690	-	-	6290	6460	-	-	6690	-	
6.3	8750	-	-	-	8360	-	-	-	8760	8760	-	-	8360	-	-	-	8760	-		
4 хода																				
800	1.6	6690	7000	9200	9700	6220	6550	8490	8870	6800	6800	9200	9700	6220	6550	8490	8870	6800	9370	
	2.5	7180	7480	9780	10220	6700	6950	9070	9450	7290	7290	9780	10220	6700	6950	9070	9450	7290	9950	
	4.0	8150	8450	10700	11200	7750	7920	9990	10500	8250	8250	10700	11200	7750	7920	9990	10500	8250	10870	
	6.3	10400	-	13050	-	9910	-	12340	-	10490	10490	13050	-	9910	-	12340	-	10490	13220	
	2 хода																			
	1.6	6540	6850	8970	9390	6050	6400	8240	8590	6650	6650	8970	9390	6050	6400	8240	8590	6650	9060	
2.5	7030	7350	9550	9970	6530	6770	8820	9170	7090	7090	9550	9970	6530	6770	8820	9170	7090	9640		
4.0	8050	8400	10500	10950	7600	7840	9740	10100	8050	8050	10500	10950	7600	7840	9740	10100	8050	10560		
6.3	10300	-	12850	-	9790	-	12090	-	10300	10300	12850	-	9790	-	12090	-	10300	12910		
4 хода																				



Continuation sheet

Shell inner diameter	Pressure PN, MPa, max	Dimensions, mm											
		Tubes 20x2, length						Tubes 25x2, length					
		9000			6000			9000			6000		
		Steel	Brass	Steel	Brass	Steel	Brass	Steel	Brass	Steel	Brass	Steel	Brass
Tubes material													
Weight, kg													
900	2 passes	1.6	8400	11400	8790	11990	7610	10190	7930	10660	8350	11320	
		2.5	9720	13000	10110	13590	8930	11790	9250	12260	9670	12920	
		4.0	11510	14890	11900	15480	10660	13680	10980	14120	11390	14810	
		6.3	15090	-	15480	-	14320	-	14680	-	1504	18760	
		4 passes											
		1.6	8240	11150	8640	11710	7480	9960	7780	10410	8180	11030	
	2.5	9540	12720	9920	13280	8760	11520	9060	11970	9460	12590		
	4.0	11190	14550	11570	15110	10420	13350	10720	13800	11110	14410		
	6.3	14760	-	15140	-	13990	-	14300	-	14690	18280		
	1000	2 passes	1.6	10220	10750	13920	14650	9400	9900	12630	13300	10300	14050
			2.5	11020	11500	14770	15500	10160	10600	13480	14200	11100	14900
			4.0	13220	13700	16920	17680	12360	12760	15630	16350	13300	17050
6.3			18900	-	13960	-	18040	-	22670	-	18980	24090	
4 passes													
1.6			10050	10600	13550	14350	9250	9750	12400	13100	10150	13750	
2.5		10800	11300	14450	15200	10000	10450	13250	13960	10950	14650		
4.0		12990	13450	16570	17270	12120	12500	15270	15850	13150	16600		
6.3		18670	-	23610	-	17800	-	22310	-	18700	23650		
1200		2 passes	1.6	15000	15750	20270	21400	13870	15000	18500	19400	15200	20600
			2.5	16750	17500	22100	23200	15470	16100	20200	21100	16900	22400
			4.0	21400	22200	26950	28100	20170	20800	25100	26000	21600	27240
	6.3		28300	-	35400	-	27100	-	33500	-	28500	35730	
	4 passes												
	1.6		14750	15460	19830	20900	13580	14160	18100	18970	14840	20060	
	2.5	16550	17250	21700	22800	15290	15870	19900	10770	16540	21860		
	4.0	21200	22000	26700	27800	19880	20460	24800	25670	21240	26700		
	6.3	28000	-	35150	-	26800	-	33100	-	28220	35200		

\* shell outer diameter



## Weight of KhP type heat exchangers at tube holes layout at equilateral triangles corners

Dimensions, mm

Shell inner diameter	Pressure PN, MPa, max	Tubes 20x2, length						Tubes 25x2, length						Tubes 25x2.5, length					
		6000		9000		9000		6000		9000		9000		6000		9000			
		Steel	Brass	Steel	Brass	Steel	Brass	Steel	Brass	Steel	Brass	Steel	Brass	Steel	Brass	Steel	Brass		
Tubes material																			
Weight, kg																			
600	2.5	2 passes																	
		4290	4500	-	-	3980	4150	-	-	4330	-	-	-	-	4330	-	-		
		4800	5000	-	-	4500	4650	-	-	4850	-	-	-	-	4850	-	-		
	6.3	6300	-	-	6000	-	-	-	6350	-	-	-	-	6350	-	-			
	2.5	4 passes																	
		4160	4300	-	-	3840	4000	-	-	4150	-	-	-	-	4150	-	-		
		4700	4800	-	-	4390	4600	-	-	4700	-	-	-	-	4700	-	-		
	6.3	6200	-	-	5830	-	-	-	6200	-	-	-	-	6200	-	-			
	700	2.5	2 passes																
6290			6540	-	-	5870	6080	-	-	6380	-	-	-	-	6380	-	-		
7190			7440	-	-	6770	6980	-	-	7280	-	-	-	-	7280	-	-		
6.3		9290	-	-	8880	-	-	-	9360	-	-	-	-	9360	-	-			
2.5		4 passes																	
		6090	6310	-	-	5620	5800	-	-	6050	-	-	-	-	6050	-	-		
		6920	7140	-	-	6440	6620	-	-	6870	-	-	-	-	6870	-	-		
6.3		8970	-	-	8510	-	-	-	8940	-	-	-	-	8940	-	-			
800		1.6	2 passes																
	7200		7560	9650	10170	6580	6860	8600	8600	9050	9050	7240	7240	9600					
	7550		7900	10150	10670	7000	7280	9100	9100	9550	9550	7590	7590	10100					
	4.0	8600	9000	11450	12050	7980	8260	10400	10400	10900	10900	8640	8640	11400					
	6.3	10600	-	13800	-	9980	-	12750	-	10640	-	13750							
	1.6	4 passes																	
		7000	7320	9300	9790	6370	6640	8280	8280	8670	8670	9690	9690	9100					
		7380	7700	9800	10290	6770	7040	8750	8750	9150	9150	7360	7360	9400					
	4.0	8470	8850	11150	11670	7750	8100	10150	10150	10570	10570	8430	8430	11000					
6.3	10470	-	13500	-	9750	-	12500	-	10430	-	13350								



Shell inner diameter		Dimensions, mm										Continuation sheet			
		Tubes 20x2, length		Tubes 25x2, length		Tubes 25x2.5, length		Tubes 20x2, length		Tubes 25x2, length				Tubes 25x2.5, length	
		6000	9000	6000	9000	6000	9000	6000	9000	6000	9000			6000	9000
Pressure PN, MPa, max	Weight, kg	Tubes material													
		Steel	Brass	Steel	Brass	Steel	Brass	Steel	Brass	Steel	Brass	Steel	Brass		
900	2 passes	1.6	8960	9400	12240	12910	8120	8490	10960	11500	8980	12260			
		2.5	10280	10720	13840	14510	9440	9810	12560	13100	10300	13860			
		4.0	12070	12510	15730	16400	11170	11540	14450	14960	12020	15750			
		6.3	15650	-	19680	-	14830	-	18400	-	15670	19700			
		1.6	8710	9160	11860	12490	7910	8250	10600	11110	8710	11820			
		2.5	10010	10440	13430	14060	9190	9530	12160	12670	9990	13380			
	4 passes	4.0	11660	12090	15260	15890	10850	11190	13990	14500	11640	15200			
		6.3	15230	-	19120	-	14420	-	17860	-	15220	19070			
		1000	2 passes	1.6	10990	11600	14980	15900	9950	10750	13380	14300	11000	15000	
				2.5	11640	12300	15830	16750	10600	11250	14230	15150	11650	15850	
				4.0	13430	14050	17680	18650	12350	13000	16080	17050	13450	17700	
			4 passes	6.3	19790	-	25170	-	18730	-	23570	-	19800	25190	
1.6	10730			11350	14700	15500	9650	10300	13000	13900	10650	14600			
2.5	11480			12050	15500	16350	10500	11000	13850	14750	11400	15400			
1200	2 passes	4.0	13180	13800	17350	18250	12100	12750	15700	16650	13100	17250			
		6.3	19470	-	24700	-	18360	-	22880	-	19360	24590			
		1.6	16650	17750	23200	24500	15200	16050	21060	22120	16870	23550			
	4 passes	2.5	17850	18800	24550	25850	16400	17100	22400	23460	18070	24900			
		4.0	22170	-	29820	-	20700	-	27680	-	22390	30170			
		6.3	27940	-	36410	-	26500	-	34270	-	28160	36760			
1.6	16300	17550	22850	23600	14820	15800	20400	21430	16360	22780					
2.5	17550	18600	24300	24900	15980	16850	21770	22750	17560	24130					
4.0	21760	-	29200	-	20280	-	27050	-	21880	29400					
6.3	27530	-	35800	-	26080	-	33640	-	27650	35900					



Weight of KP type heat exchangers at tube holes layout at equilateral triangles corners  
Dimensions, mm

Shell inner diameter	Pressure PN, MPa, max	Tubes 20x2, length		Tubes 25x2, length		Tubes 25x2.5, length				
		6000								
		Steel		Brass		Steel		Brass		
Weight, kg										
600	1.0	2 passes						4000	4100	
		4080		4300		3760				
		4250		4450		3940				
		4300		4500		4050		4300		
		4 passes						3780	4060	
		3880		4100		3600				
		4060		4230		3750				
		4100		4300		3860		4150		
		6 passes						3700	3980	
	3800		4020		3550					
	3980		4150		3700					
	4030		4220		3800		4050			
	700	1.0	2 passes						5050	5340
			5260		5520		4850			
			5660		5910		5240			
			6230		6480		5810		6020	
			4 passes						4780	5020
			5090		5310		4610			
5450			5670		4980					
6010			6230		5540		5970			
6 passes						4760	5010			
5000		5230		4590						
5390		5610		4970						
5950		6170		5530		5970				
800		1.0	2 passes						6670	7040
			6960		7290		6400			
			7330		7670		6760			
			7480		7830		6820		7100	
			4 passes						6390	6720
			6710		7010		6140			
	7080		7390		6500					
	7230		7550		6560		6820			
	6 passes						6280	6590		
	6610		6900		6040					
	6980		7280		6400					
	7130		7440		6460		6710			





Shell inner diameter	Pressure PN, MPa, max	Dimensions, mm						Tubes 25x2.5, length	Continuation sheet
		Tubes 20x2, length			Tubes 25x2, length				
		Steel	Brass	Weight, kg	Steel	Brass	Weight, kg		
900	6000	Tubes material							
		2 passes							
		1.0	8880	9310	8040	8410	8890		
		1.6	9260	9700	8420	8790	9280		
		2.5	9940	10380	9100	9470	9960		
		4 passes							
		1.0	8580	9020	7790	8120	8570		
		1.6	8960	9410	8160	8500	8960		
		2.5	9660	10090	8840	9180	9640		
	6 passes								
	1.0	8500	8890	7640	7970	8390			
	1.6	8880	9280	8020	8350	8780			
2.5	9570	9970	8710	9040	9470				
1000		2 passes							
		1.0	104150	11050	9450	10100	10500		
		1.6	11500	12100	10400	10860	11500		
		2.5	12000	12600	10900	11360	12000		
		4 passes							
		1.0	10150	10700	9150	9800	10100		
		1.6	11200	11800	10100	10490	11100		
		2.5	11700	12250	10570	10990	11600		
		6 passes							
	1.0	10000	10550	9100	9600	10100			
	1.6	11050	11600	9950	10370	10950			
	2.5	11550	12100	10450	10870	11460			
1200		2 passes							
		1.0	16450	17300	15000	15700	16600		
		1.6	17300	18100	15900	16600	17450		
		2.5	18000	18830	16500	17400	18200		
		4 passes							
		1.0	16040	16850	14570	15200	16050		
		1.6	16900	17700	15470	16100	16900		
		2.5	17600	18400	16100	16950	17700		
		6 passes							
	1.0	15860	16600	14400	15040	15860			
	1.6	16700	17460	15300	15900	16700			
	2.5	17400	18200	15950	16500	17500			



## Weight of TU type heat exchangers at tube holes layout at equilateral triangles corners

Dimensions, mm

Shell inner diameter	Pressure PN, MPa, max	Tubes, 20x2, length			Tubes 25x2, length			Tubes 25x2.5, length		
		3000	6000	9000	3000	6000	9000	3000	6000	9000
		Tubes material								
		Steel	Steel	Steel	Steel	Steel	Steel	Steel	Steel	Steel
Weight, kg										
325*	2.5	730	1180	-	700	1100	-	720	1170	-
	4.0	780	1230	-	750	1200	-	770	1220	-
400	2.5	1110	1910	-	1000	1700	-	1080	1880	-
	4.0	1210	1990	-	1100	1780	-	1180	1950	-
	6.3	1460	2350	-	1350	2150	-	1450	2300	-
500	2.5	1630	2700	-	1500	2450	-	1650	2780	-
	4.0	1930	3130	-	1800	2900	-	1950	3210	-
	6.3	2370	3700	-	2250	3450	-	2400	3790	-
600	1.6	-	3980	-	-	3600	-	-	4000	-
	2.5	-	4030	-	-	3700	-	-	4050	-
	4.0	-	4430	-	-	4100	-	-	4450	-
	6.3	-	5480	-	-	5150	-	-	5500	-
700	1.6	-	5340	-	-	4790	-	-	5330	-
	2.5	-	5720	-	-	5170	-	-	5710	-
	4.0	-	6400	-	-	5850	-	-	6390	-
	6.3	-	7740	-	-	7190	-	-	7730	-
800	1.6	-	6650	9450	-	5850	8250	-	6550	9300
	2.5	-	7250	10050	-	6450	8850	-	7150	9900
	4.0	-	7950	11100	-	7150	9900	-	7850	10950
	6.3	-	9460	12850	-	8660	11660	-	9370	12700
900	1.6	-	8540	11860	-	7660	10570	-	8630	11990
	2.5	-	9660	13230	-	8780	11940	-	9750	13360
	4.0	-	10380	14120	-	9500	12830	-	10470	14250
1000	1.6	-	10370	14500	-	9200	12650	-	10300	14390
	2.5	-	11020	15450	-	9850	13580	-	10950	15350
	4.0	-	12370	17000	-	11200	15130	-	12300	16890
1200	1.6	-	14800	20880	-	13300	18620	-	15100	21300
	2.5	-	15800	22200	-	14300	20000	-	16100	22620
1400	1.6	-	20150	27960	-	17850	24600	-	20380	28300
	2.5	-	21730	31000	-	19420	27630	-	21960	31340

\* Shell outer diameter.

**Notes:**

- Heat exchangers weight is calculated for steels with density of 7.85 g/cm<sup>3</sup>.
- Tubes 25x2 should be made of high alloy steels and brass.
- Tubes 25x2.5 should be made of carbon and low alloy steels.
- Weight tolerance should not exceed +8%.
- Weight was calculated for nominal thickness of heat exchange tubes and sheet metal excluding weight of hanger for distributing chambers and covers to them.



## Layout of Foundation Bolts Holes in Supports for Horizontal Heat Exchangers

For shells with 325 - 600 mm diameter

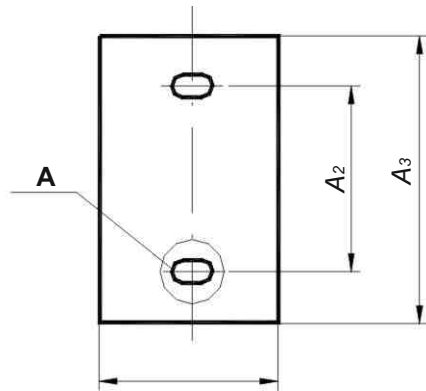

For shells with 700 - 1400 mm diameter

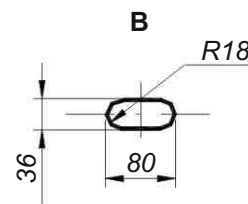
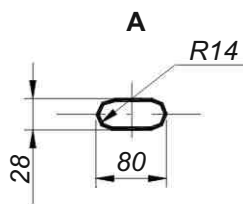
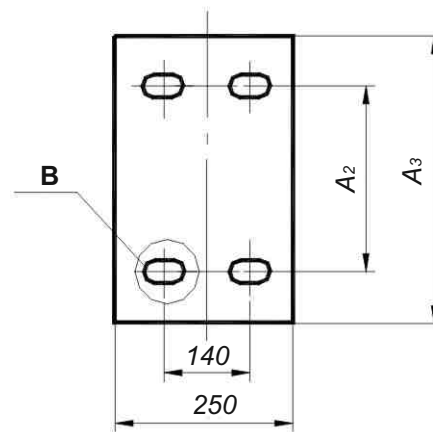

### Notes:

1. For supports of heat exchangers of 700 and 800 mm diameter, groove in base plate should be 80x30 mm.
2. It is allowed to make holes of the same dimensions as for movable support instead of foundation bolts grooves for fixed support in base plate.

Dimensions, mm

Heat exchanger type	Shell inner diameter, Di	A <sub>2</sub>	A <sub>3</sub>
TP, KhP, TU	325*	330	400
	400		450
	500	380	500
TP, KhP, KP, TU	600	450	600
	700	480	700
	800	500	740
	900	600	850
	1000	650	1000
	1200	800	1100
TU	1400	950	1250

\* shell outer diameter



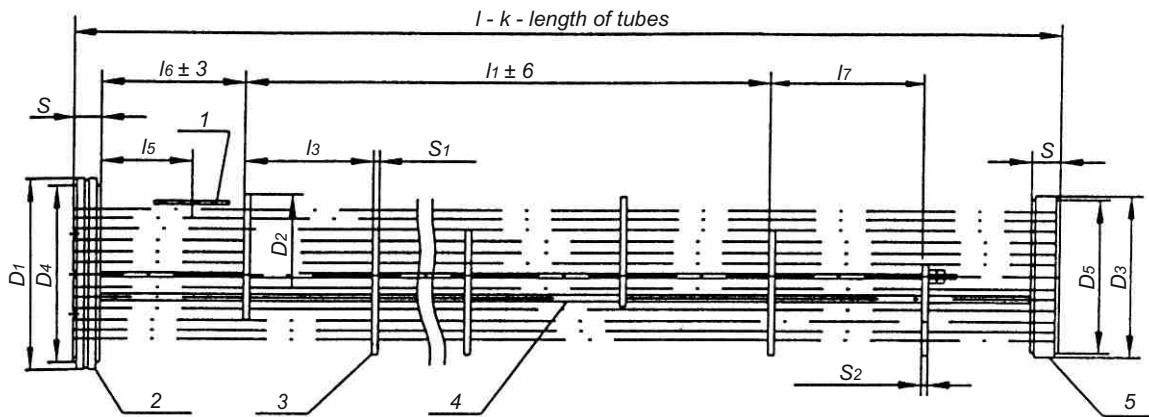

1 - baffle plate; 2 - fixed sheet; 3 - partition wall; 4 - heat exchange tube; 5 - movable sheet

## Basic Dimensions of Tube Bundles for TP and KhP Types Heat Exchangers

Basic dimensions of tube bundles for TP and KhP types heat exchangers

Shell inner diameter	Pressure, PN, MPa, max	Dimensions, mm													
		D <sub>1</sub>	D <sub>2</sub>	D <sub>3</sub>	D <sub>4</sub>	D <sub>5</sub>	Tube length l	l <sub>3</sub>	l <sub>4</sub>	~l <sub>5</sub>	~l <sub>6</sub>	~l <sub>7</sub>	S	S <sub>1</sub>	S <sub>2</sub>
325*	2.5	363	D <sub>2</sub> **	294	D <sub>4</sub> ***	276	3000	140	2100	205	330	200	40	4	6
	6000						5180		290	40					
	4.0	3000	2100	225	340	300	400	50							
400	6.3	410	397	396	372	3000	210	1890	225	410	330	45	6	8	
	2.5	6000				4830		440		40					
	4.0	3000	395	372	405	435	380	50							
500	6.3	490	497	496	470	3000	260	1890	250	410	310	55	6	8	
	2.5	6000				1820		440		50					
	4.0	3000	495	470	440	380	440	55							
600	6.3	590	592	592	568	3000	320	1820	290	410	360	70	6	8	
	8.0	6000				4420		610		45					
	1.6	3000	4800	280	430	275	425	55							
700	2.5	663	696	690	660	6000	360	4800	290	420	420	65	6	8	
	4.0	657				59		568		290		420			80
	6.3	710	696	690	660	345	645	85							
800	8.0	741	796	790	760	3000	385	4160	455	655	670	90	8	10	
	1.6	6000				4290		275		485		730			55
	2.5	9000	7410	325	500	670	60								
800	4.0	868	796	790	760	6000	390	4290	320	725	670	65	8	10	
	6.3	935				4290		320		665		75			
	8.0	974	796	790	760	3960	4290	340	480	725	670	95			
800	1.6	865	796	790	760	6000	385	4235	400	620	670	105	8	10	
	2.5	9000				7410		325		575		860			
	4.0	875	796	790	760	4290	7410	340	480	725	670	95			



# Basic Dimensions of Tube Bundles for TP and KhP Types Heat Exchangers

Shell inner diameter	Pressure, PN, MPa, max	Dimensions, mm										Continuation sheet																
		D <sub>1</sub>	D <sub>2</sub>	D <sub>3</sub>	D <sub>4</sub>	D <sub>5</sub>	Tube length	I <sub>3</sub>	I <sub>4</sub>	~I <sub>5</sub>	~I <sub>6</sub>	~I <sub>7</sub>	S	S <sub>1</sub>	S <sub>2</sub>													
700	1.6	763	696	690	695	660	6000	360	4680	275	485	420	50															
	2.5	773								290	500					65												
	4.0	757								325	485																	
	6.3	825								385	780																	
	8.0	859								480	725																	
800	1.6	865	796	790	795	760	6000	385	4290	730	670	55																
	2.5	875							390	4290					7410	320	665	620	580									
		868																		4290	7410	340	695					
		935																						4235	7315	400	620	
		974																										3510
900	1.6	965	895	890	895	862	6000	390	4005	830	400	60																
	2.5	977							445	4005					7565	340	810	530	830	550								
		968																			4005	7500	380	920				
		1060																							4005	6675	495	690
		1064																										
1000	1.6	1064	995	990	995	962	6000	500	4500	590	590	65																
	2.5	1078							490	4500					7500	340	590	6000	500									
		1073																		4410	7350	375	605					
		1163																						3500	6500	605	955	
		1266																										4305
1200	1.6	1266	1195	1190	1195	1158	6000	615	4305	620	570	70																
	2.5	1294							615	4305					6765	390	890	6000	620									
		1287																		3075	6765	515	805					
		1385																						3075	6765	635	1000	
																												5535

\* shell outer diameter Do

\*\* D<sub>2</sub> is calculated as per D<sub>i actual</sub> minus 3 mm.\*\*\* D<sub>4</sub> is calculated as per D<sub>i actual</sub> minus 5 mm.

# 46 Tube Bundle of KP Type Heat Exchangers

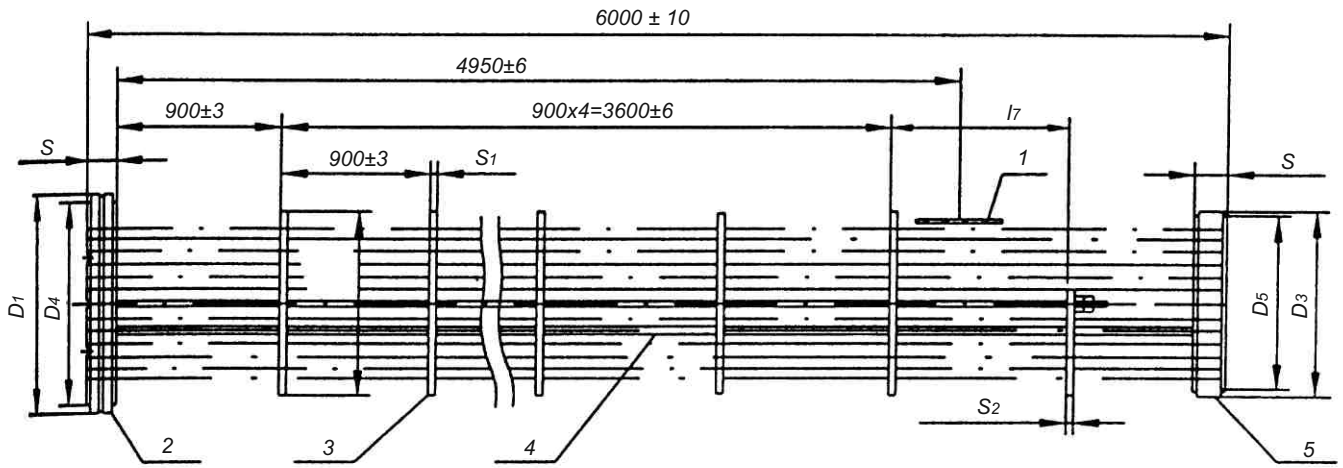

1 - baffle plate; 2 - fixed sheet; 3 - partition wall; 4 - heat exchange tube; 5 - movable sheet

Basic dimensions of tube bundles for KP type heat exchangers

Dimensions, mm

Shell inner diameter	Pressure PN, MPa, max	$D_1$	$D_2$	$D_3$	$D_4$	$D_5$	S	$S_1$	$S_2$	$\sim l_7$		
600	1.0	663	597	592	595	568	40	10	12	690		
	1.6						45					
	2.5						55					
700	1.0	763	696	690	695	660	45	12	14			
	1.6	50										
	2.5	60										
800	1.0	865	796	790	795	760	50			12	14	
	1.6	55										
	2.5	65										
900	1.0	965	895	890	895	862	55	12	14			740
	1.6	60										
	2.5	70										
1000	1.0	1064	995	990	995	962	55			12	14	
	1.6	65										
	2.5	75										
1200	1.0	1266	1195	1190	1195	1158	60	12	14			840
	1.6	70										
	2.5	85										



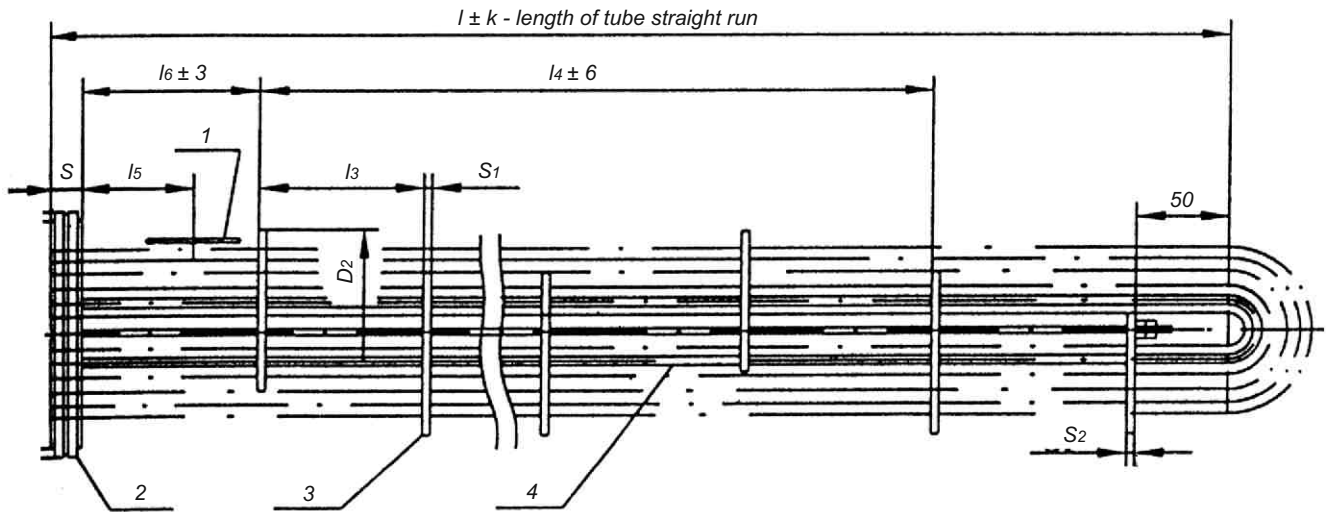

1 - baffle plate; 2 - fixed sheet; 3 - partition wall; 4 - heat exchange tube;



## Basic Dimensions of Tube Bundles for TU Type Heat Exchangers

Dimensions, mm

Shell inner diameter	Pressure PN, MPa, max	$D_1$	$D_2$	$D_4$	Tubes length $l$	$l_3$	$l_4$	$\sim l_5$	$\sim l_6$	S	$S_1$	$S_2$	
325*	2.5	363	298**	296**	3000	150	2250	205	330	45	4	6	
					6000		5250						
	4.0				3000		2250	220	32	55			
					6000		5250						
400	2.5	457	397	395	3000	200	2200	225	375	55	6	8	
					6000		5000		475				
	4.0				3000		2200	220	370	65			
					6000		5000		470				
	6.3	490			3000		2200	240	370	75			
					6000		500		470				
500	2.5	563	479	495	3000	250	2250	245	370	60	6	8	
					6000		5220						
	4.0				3000		2250	240	365	75			
					6000		5220						
	6.3	590			3000		2250	280	385	90			
					6000		5220						
600	1.6	663	597	595	6000	335	5025	270	455	60	6	8	
	2.5							265		70			
	4.0							280	85				
	6.3							335	105				
700	1.6	763	696	695	6000	380	4940	270	500	65	6	8	
	2.5							280		80			
	4.0							315	95				
	6.3							370	115				
800	1.6	865	796	795	6000	420	4620	315	705	75	8	10	
					9000		7980		525				
					6000		4620	305	695	90			
					9000		7980		515				
	2.5				6000		4620	320	690	110			
					9000		7980		510				
					4.0		6000	4620	390	760			135
							9000	7980		580			
900	1.6	965	895	895	6000	445	4895	320	570	85	6	8	
					9000		7565		735				
					2.5		6000	4895	330	580			95
							9000	7565		745			
	4.0				968		6000	4895	360	595			120
							9000	7565		760			



## Basic Dimensions of Tube Bundles for TU Type Heat Exchangers

Dimensions, mm

Continuation sheet

Shell inner diameter	Pressure PN, MPa, max	$D_1$	$D_2$	$D_4$	Tubes length $l$	$l_3$	$l_4$	$\sim l_5$	$\sim l_6$	S	$S_1$	$S_2$			
1000	1.6	1064	995	995	6000	500	4500	335	785	85	8	10			
					9000		7500								
	2.5	1078			6000		4500	325	775	105					
					9000		7500								
	4.0	1073			6000		4500	375	805	135					
					9000		7500								
1200	1.6	1266	1195	1195	6000	615	4305	360	910	100	10	12			
					9000		7995		565						
					2.5		1294	600	4305	375			905	120	
	9000	7995						560							
	1.6	1468						1395	1395	6000			670	4690	445
					9000		7370			860					
2.5			1504	6000	4690	430	685			140					
	9000	7370		845											

\* Shell outer diameter.

\*\* Dimension is specified for heat exchangers with tubes  $\varnothing 325 \times 12$ .  
Thickness of sheet S for material design M3 should be increased by 5 mm.



## Weight of Tube Bundles for TP and KhP Types Heat Exchangers at Tubes Holes Layout at Squares Apexes

Dimensions, mm

Shell inner diameter	Pressure in shell PN, MPa, max	Tubes 20x2, length		Tubes 25x2, length				Tubes 25x2.5, length			
		3000	6000	3000	6000	3000	6000	3000	6000		
		Tubes material									
		Steel	Brass	Steel	Brass	Steel	Brass	Steel	Brass	Steel	Steel
		Weight, kg									
325*	2.5***	260	280	500	540	230	250	430	460	260	500
	4.0	270	290	510	550	240	260	440	470	270	510
	6.3**	300	320	540	580	270	290	470	500	300	540
400	2.5***	480	510	890	950	430	460	780	840	490	910
	4.0	490	520	900	960	440	470	790	850	500	920
	6.3	510	-	920	-	460	-	810	-	520	940
500	2.5***	780	840	1520	1630	670	710	1290	1370	770	1490
	4.0	810	870	1550	1660	700	740	1320	1400	800	1520
	6.3	850	-	1590	-	740	-	1360	-	840	1560
	8.0***	890	-	1630	-	780	-	1400	-	880	1600

Dimensions, mm

Shell inner diameter	Pressure in shell PN, MPa, max	Tubes 20x2, length		Tubes 25x2, length				Tubes 25x2.5, length			
		6000	9000	6000	9000	6000	9000	6000	9000		
		Tubes material									
		Steel	Brass	Steel	Brass	Steel	Brass	Steel	Brass	Steel	Steel
		Weight, kg									
600	<b>2 passes</b>										
	1.6***	2090	2250	-	-	1820	1950	-	-	2140	-
	2.5	2130	2290	-	-	1860	1990	-	-	2180	-
	4.0	2150	2310	-	-	1880	2010	-	-	2200	-
	6.3	2230	-	-	-	1960	-	-	-	2280	-
	8.0***	2270	-	-	-	2000	-	-	-	2320	-
	<b>4 passes</b>										
	1.6***	1970	2110	-	-	1720	1840	-	-	2010	-
	2.5	2010	2150	-	-	1760	1880	-	-	2050	-
	4.0	2030	2170	-	-	1780	2000	-	-	2070	-
	6.3	2110	-	-	-	1860	-	-	-	2150	-
	8.0***	2150	-	-	-	1900	-	-	-	2190	-



# Weight of Tube Bundles for TP and KhP Types Heat Exchangers at Tubes Holes Layout at Squares Apexes

Dimensions, mm

Continuation sheet

Shell inner diameter	Pressure in shell PN, MPa, max	Tubes 20x2, length				Tubes 25x2, length				Tubes 25x2.5, length	
		6000		9000		6000		9000		6000	9000
		Tubes material									
		Steel	Brass	Steel	Brass	Steel	Brass	Steel	Brass	Steel	Steel
		Weight, kg									
700	<b>2 passes</b>										
	1.6***	2980	3210	-	-	2530	2710	-	-	2980	-
	2.5	3030	3260	-	-	2580	2760	-	-	3030	-
	4.0	3060	3290	-	-	2610	2790	-	-	3060	-
	6.3	3180	-	-	-	2740	-	-	-	3160	-
	8.0***	3260	-	-	-	2820	-	-	-	3240	-
	<b>4 passes</b>										
	1.6***	2790	2990	-	-	2390	2560	-	-	2790	-
	2.5	2840	3040	-	-	2440	2610	-	-	2840	-
	4.0	2880	3080	-	-	2470	2640	-	-	2870	-
6.3	3000	-	-	-	2610	-	-	-	3010	-	
8.0***	3080	-	-	-	2690	-	-	-	3090	-	
800	<b>2 Passes</b>										
	1.6	3780	4080	5560	6000	3310	3560	4850	5230	3890	5730
	2.5	3840	4140	5620	6060	3370	3620	4910	5290	3950	5790
	4.0	389	4190	5670	6110	3420	3670	4960	5340	4000	5840
	6.3	4070	-	5850	6290	3600	-	5140	-	4180	6020
	8.0***	4180	-	5960	6400	3710	-	525	-	4290	6130
	<b>4 Passes</b>										
	1.6	3630	3920	5330	5750	3140	3380	4600	4950	3690	5420
	2.5	3690	3980	5390	5810	3200	3440	4660	5010	3750	5480
	4.0	3740	4030	5440	5860	3250	3490	4710	5060	3800	5530
6.3	3920	-	5620	6040	3430	-	4890	-	3980	5710	
8.0***	4030	-	5730	6150	3540	-	5000	-	4090	5820	
900	<b>2 passes</b>										
	1.6	4950	5340	7250	7840	4160	4480	6040	6510	4900	7170
	2.5	5030	5420	7330	7920	4240	4560	6120	6590	4980	7250
	4.0	5130	5520	7390	7980	4280	4600	6180	6620	5010	7310
	6.3	5380	-	7720	-	4610	-	6510	-	5330	7640
	<b>4 Passes</b>										
	1.6	4720	5120	6930	7490	3960	4260	5740	6190	4660	6810
	2.5	4820	5200	7020	7580	4040	4340	5820	6270	4740	6890
4.0	4850	5230	7090	7650	4080	4380	5890	6340	4770	6950	
6.3	5180	-	7420	-	4410	-	6230	-	5110	7290	



# Weight of Tube Bundles for TP and KhP Types Heat Exchangers at Tubes Holes Layout at Squares Apexes

Dimensions, mm

Continuation sheet

Shell inner diameter	Pressure in shell PN, MPa, max	Tubes 20x2, length				Tubes 25x2, length				Tubes 25x2.5, length	
		6000		9000		6000		9000		6000	9000
		Tubes material									
		Steel	Brass	Steel	Brass	Steel	Brass	Steel	Brass	Steel	Steel
		Weight, kg									
1000	<b>2 passes</b>										
	1.6	6060	6540	8850	9580	5200	5600	7560	8170	6140	8980
	2.5	6160	6640	8950	9680	5300	5700	7660	8270	6240	9080
	4.0	6280	6760	9070	9800	5420	5820	7780	8390	6360	9200
	6.3	6580	-	9370	-	5720	-	8080	-	6660	9500
	<b>4 passes</b>										
	1.6	5830	6290	8500	9200	4960	5340	7200	7780	5850	8540
	2.5	5930	6390	8600	9300	5060	5440	7300	7880	5950	8640
	4.0	6050	6510	8720	9420	5180	5560	7420	8000	6070	8760
	6.3	6350	-	9020	-	5480	-	7720	-	6370	9060
1200	<b>2 passes</b>										
	1.6	8930	9660	12980	14100	7710	8320	11170	12080	9140	13310
	2.5	9140	9870	13190	14310	7920	8530	11380	12290	9350	13520
	4.0	9310	10040	13360	14480	8090	8700	11550	12460	9520	13690
	6.3	9800	-	13850	-	8580	-	12040	-	10010	14180
	<b>4 passes</b>										
	1.6	8360	9340	12540	13610	7420	8000	10730	11600	8780	12770
	2.5	8840	9550	12750	13820	7630	8210	10940	11810	8990	12980
	4.0	9010	9720	12920	13990	7800	8380	11110	11980	9160	13150
	6.3	9500	-	13410	-	8290	-	11600	-	9650	13640

\* shell outer diameter

\*\* for KhP type heat exchangers only

\*\*\* for TP type heat exchangers only



## Weight of Tube Bundles for TP and KhP Types Heat Exchangers at Tubes Holes Layout at Equilateral Triangles Corners

		Dimensions, mm									
Shell inner diameter	Pressure in shell PN, MPa, max	Tubes 20x2, length				Tubes 25x2, length				Tubes 25x2.5, length	
		6000		9000		6000		9000		6000	9000
		Tubes material									
		Steel	Brass	Steel	Brass	Steel	Brass	Steel	Brass	Steel	Steel
		Weight, kg									
600	<b>2 passes</b>										
	1.6*	2310	2490	-	-	1990	2140	-	-	2350	-
	2.5	2350	2530	-	-	2030	2180	-	-	2390	-
	4.0	2370	2550	-	-	2050	2200	-	-	2410	-
	6.3	2450	-	-	-	2130	-	-	-	2490	-
	8.0*	2490	-	-	-	2170	-	-	-	2530	-
	<b>4 passes</b>										
	1.6*	2140	2290	-	-	1820	1950	-	-	2130	-
	2.5	2180	2330	-	-	1860	1990	-	-	2170	-
	4.0	2200	2350	-	-	1880	2110	-	-	2190	-
6.3	2280	-	-	-	1960	-	-	-	2270	-	
8.0*	2320	-	-	-	2000	-	-	-	2310	-	
700	<b>2 passes</b>										
	1.6*	3240	3490	-	-	2820	3030	-	-	3330	-
	2.5	3290	3540	-	-	2870	3080	-	-	3380	-
	4.0	3320	3570	-	-	2900	3110	-	-	3410	-
	6.3	3440	-	-	-	3030	-	-	-	3510	-
	8.0*	3520	-	-	-	3110	-	-	-	3590	-
	<b>Passes</b>										
	1.6	3010	3230	-	-	2540	2720	-	-	2970	-
	2.5	3060	3280	-	-	2590	2770	-	-	3020	-
	4.0	3100	3320	-	-	2620	2800	-	-	3050	-
6.3	3220	-	-	-	2760	-	-	-	3190	-	
8.0*	3300	-	-	-	2840	-	-	-	3270	-	
800	<b>2 passes</b>										
	1.6	4300	4650	6340	6860	3670	3950	5390	5820	4330	6390
	2.5	4360	4710	6400	6920	3730	4010	5450	5880	4390	6450
	4.0	4410	4760	6450	6970	3780	4060	5500	5930	4440	6500
	6.3	4590	-	6630	-	3960	-	5680	-	4620	6680
	8.0*	4700	-	6740	-	4070	-	5790	-	4730	6790



# Weight of Tube Bundles for TP and KhP Types Heat Exchangers at Tubes Holes Layout at Equilateral Triangles Corners

Dimensions, mm

Continuation sheet

Shell inner diameter	Pressure in shell PN, MPa, max	Tubes 20x2, length				Tubes 25x2, length				Tubes 25x2.5, length	
		6000		9000		6000		9000		6000	9000
		Tubes material									
		Steel	Brass	Steel	Brass	Steel	Brass	Steel	Brass	Steel	Steel
		Weight, kg									
800	<b>4 passes</b>										
	1,6	4080	4410	6000	6480	3430	3700	5030	5420	4040	5950
	2,5	4140	4470	6060	6540	3490	3760	5090	5480	4100	6010
	4,0	4190	4520	6110	6590	3540	3810	5140	5530	4150	6060
	6,3	4370	-	6290	-	3720	-	5320	-	4330	6240
	8,0*	4480	-	6400	-	3830	-	5430	-	4440	6350
900	<b>2 passes</b>										
	1,6	5510	5950	8090	8760	4670	5040	6810	7350	5530	8110
	2,5	5590	6030	8170	8840	4750	5120	6890	7430	5610	8190
	4,0	5690	6130	8230	8900	4790	5160	6950	7460	5640	8250
	6,3	5940	-	8560	-	5120	-	7280	-	5960	8580
	<b>4 Passes</b>										
	1,6	5190	5640	7640	8270	390	4730	6380	6890	5190	7600
	2,5	5290	5720	7730	8360	4470	4810	6460	6970	5270	7680
	4,0	5320	5750	7800	8430	4510	4850	6530	7040	5300	7740
	6,3	5650	-	8130	-	4840	-	6870	-	5640	8080
1000	<b>2 passes</b>										
	1,6	6840	7400	10020	10860	5780	6240	8430	9130	6850	10050
	2,5	6940	7500	10120	10960	5880	6340	8530	9230	6950	10150
	4,0	7060	7620	10240	11080	6000	6460	8650	9350	7070	10270
	6,3	7360	-	10540	-	6300	-	8950	-	7370	10570
	<b>4 Passes</b>										
	1,6	6520	7050	9540	10340	5440	5870	7930	8580	6440	9430
	2,5	6620	7150	9640	10440	5540	5970	8030	8680	6540	9530
	4,0	6740	7270	9760	10560	5660	6090	8150	8800	6660	9650
	6,3	7040	-	10060	-	5960	-	8450	-	6960	9950



## Weight of Tube Bundles for TP and KhP Types Heat Exchangers at Tubes Holes Layout at Equilateral Triangles Corners

Dimensions, mm

Continuation sheet

Shell inner diameter	Pressure in shell PN, MPa, max	Tubes 20x2, length				Tubes 25x2, length				Tubes 25x2.5, length	
		6000		9000		6000		9000		6000	9000
		Tubes material									
		Steel	Brass	Steel	Brass	Steel	Brass	Steel	Brass	Steel	Steel
		Weight, kg									
1200	<b>2 passes</b>										
	1.6	10190	11040	14870	16170	8750	9460	12730	13790	10410	15220
	2.5	10400	11250	15080	16380	8960	9670	12940	14000	10620	15430
	4.0	10570	11420	15250	16550	9130	9840	13110	14170	10790	15600
	6.3	11060	-	15740	-	9260	-	13600	-	11280	16090
	<b>4 Passes</b>										
	1.6	9780	10600	14260	15500	8330	9000	12100	13100	9900	14450
	2.5	9990	10810	14470	15710	8540	9210	12310	13310	10110	14660
	4.0	10160	10980	14640	15880	8710	9380	12480	13480	10280	14830
	6.3	10650	-	15130	-	9200	-	12970	-	10770	15320

\* for TP type heat exchangers only

Note: For heat exchangers of KhP type is specified in shell.



## Weight of Tube Bundles for KP Type Heat Exchangers at Tubes Holes Layout at Equilateral Triangles Corners

Dimensions, mm						
Shell inner diameter	Pressure in shell PN, MPa, max	Tubes 20x2, length		Tubes 25x2, length		Tubes 25x2.5, length
		6000				
		Tubes material				
		Steel	Brass	Steel	Brass	Steel
		Weight, kg				
600	<b>2 passes</b>					
	1.0	2220	2400	1900	2050	2240
	1.6	2280	2470	1960	2120	2320
	2.5	2310	2500	1990	2150	2350
	<b>4 passes</b>					
	1.0	2020	2180	1710	1830	2000
	1.6	2080	2250	1770	1900	2080
	2.5	2110	2280	1800	1930	2110
	<b>6 passes</b>					
	1.0	1950	2100	1640	1760	1920
	1.6	2010	2170	1720	1840	2010
	2.5	2040	2200	1750	1870	2040
700	<b>2 passes</b>					
	1.0	3130	3390	2720	2920	3210
	1.6	3240	3490	2820	3030	3330
	2.5	3290	3540	2870	3080	3380
	<b>4 passes</b>					
	1.0	2940	3160	2460	2630	2870
	1.6	3010	3230	2540	2720	2970
	2.5	3060	3280	2590	2770	3020
	<b>6 passes</b>					
	1.0	2820	3050	2410	2580	2830
	1.6	2930	3150	2510	2690	2950
	2.5	2980	3200	2560	2740	3000
800	<b>2 passes</b>					
	1.0	4070	4430	3480	3750	4120
	1.6	4180	4550	3580	3860	4240
	2.5	4320	4700	3630	3910	4290
	<b>4 passes</b>					
	1.0	3850	4210	3220	3470	3800
	1.6	3960	4330	3320	3580	3920
	2.5	4100	4480	3370	3630	3970
	<b>6 passes</b>					
	1.0	3720	4040	3120	3360	3670
	1.6	3830	4160	3220	3470	3790
	2.5	3970	4310	3270	3520	3840



# Weight of Tube Bundles for KP Type Heat Exchangers at Tubes Holes Layout at Equilateral Triangles Corners

Dimensions, mm

Continuation sheet

Shell inner diameter	Pressure in shell PN, MPa, max	Tubes 20x2, length		Tubes 25x2, length		Tubes 25x2.5, length	
		6000					
		Tubes material					
		Steel	Brass	Steel	Brass	Steel	
		Weight, kg					
900	<b>2 passes</b>						
	1.0	5390	5820	4550	4920	5400	
	1.6	5510	5950	4670	5040	5530	
	2.5	5590	6030	4750	5120	5610	
	<b>4 passes</b>						
	1.0	5070	5510	4280	4610	5060	
	1.6	5190	5640	4390	4730	5190	
	2.5	5290	5720	4470	4810	5270	
	<b>6 passes</b>						
	1.0	4970	5360	4110	4440	4860	
	1.6	5090	5490	4230	4560	4990	
	2.5	5170	5570	4310	4640	5070	
1000	<b>2 passes</b>						
	1.0	6590	7140	5610	6070	6680	
	1.6	6760	7310	5680	6140	6760	
	2.5	6850	7400	5770	6230	6850	
	<b>4 passes</b>						
	1.0	6270	6790	5270	5700	6270	
	1.6	6440	6960	5350	5770	6350	
	2.5	6530	7050	5440	5860	6440	
	<b>6 passes</b>						
	1.0	6120	6620	5160	5580	6140	
	1.6	6280	6800	5230	5650	6210	
	2.5	6370	6890	5320	5740	6300	
1200	<b>2 passes</b>						
	1.0	9760	10580	8290	8980	9890	
	1.6	10000	10820	8540	9230	10170	
	2.5	10300	11130	8840	9550	10500	
	<b>4 passes</b>						
	1.0	9350	10140	7860	8500	9360	
	1.6	9590	10380	8110	8750	9640	
	2.5	9890	10690	8440	9100	10000	
	<b>6 passes</b>						
	1.0	9170	9930	7690	8320	9150	
	1.6	9410	10170	7940	8570	9430	
	2.5	9700	10470	8290	8940	9810	



## Weight of Tube Bundles for TU Type Heat Exchangers at Tubes Holes Layout at Equilateral Triangles Corners

Dimensions, mm

Shell inner diameter	Pressure in shell PN, MPa, max	Tubes 20x2, length			Tubes 25x2, length			Tubes 25x2.5, length		
		3000	6000	9000	3000	6000	9000	3000	6000	9000
		Tubes material								
		Steel								
		Weight, kg								
325*	2.5	330	620	-	280	510	-	320	600	-
	4.0	340	630	-	290	520	-	330	610	-
400	2.5	590	1090	-	480	880	-	550	1040	-
	4.0	600	110	-	490	890	-	560	1050	-
	6.3	610	1110	-	500	900	-	570	1060	-
500	2.5	920	1720	-	790	1460	-	930	1780	-
	4.0	940	1740	-	810	1480	-	950	1800	-
	6.3	960	1760	-	830	1500	-	970	1820	-
600	1.6	-	2370	-	-	2000	-	-	2390	-
	2.5	-	2390	-	-	2020	-	-	2410	-
	4.0	-	2420	-	-	2040	-	-	2430	-
	6.3	-	2500	-	-	2120	-	-	2510	-
700	1.6	-	3370	-	-	2820	-	-	3360	-
	2.5	-	3410	-	-	2860	-	-	3400	-
	4.0	-	3430	-	-	2880	-	-	3420	-
	6.3	-	3550	-	-	3000	-	-	3540	-
800	1.6	-	4530	6640	-	3730	5450	-	4440	6500
	2.5	-	4590	6700	-	3790	5510	-	4500	6560
	4.0	-	4650	6760	-	3850	5570	-	4560	6620
	6.3	-	4820	6930	-	4020	5740	-	4730	6790
900	1.6	-	5800	8420	-	4920	7130	-	5890	8550
	2.5	-	5850	8470	-	4970	7180	-	5940	8600
	4.0	-	5930	8550	-	5050	7260	-	6020	8680
1000	1.6	-	7330	10660	-	6060	8790	-	7250	10550
	2.5	-	7430	10760	-	6160	8890	-	7350	10650
	4.0	-	7550	10880	-	6280	9010	-	7470	10770
1200	1.6	-	10700	15500	-	9170	13240	-	10990	15920
	2.5	-	10860	15660	-	9330	13400	-	11150	16080
1400	1.6	-	15040	21670	-	12740	18300	-	15270	22010
	2.5	-	15320	21950	-	13000	18580	-	15550	22290

\* Shell outer diameter.

**Notes:**

- Heat exchangers weight is calculated for steels with density of 7.85 g/cm<sup>3</sup>.
- Tubes 25x2 should be made of high alloy steels and brass.
- Tubes 25x2.5 should be made of carbon and low alloy steels.
- Weight tolerance should not exceed +8%.



## Maximum Design Pressure Depending on Medium Design Temperature for Heat Exchangers of TP, KhP, KP, TU Types

Maximum design pressure depending on medium design temperature  
For heat exchangers of TP, KhP, KP, TU types

Pressure in shell PN, MPa, max	Maximum design pressure, MPa, at medium design temperature, °C							
	до 100	200	250*	300*	350*	400*	425*	450*
1.0	1.00	0.93	0.90	0.075	0.66	0.58	-	-
1.6	1.60	1.49	1.40	1.20	1.10	0.90	0.80	0.57
2.5	2.50	2.32	2.25	1.90	1.70	1.50	1.30	0.90
4.0	4.00	3.72	3.50	3.00	2.60	2.30	2.00	1.40
6.3	6.30	6.00	5.40	4.80	4.00	3.70	3.20	2.30
8.0	8.00	7.00	6.80	6.00	5.20	4.60	4.00	3.20

\* for heat exchangers with stainless tubes only



# Order Form for Manufacture of Heat Exchanger or Tube Bundle (at Individual Supply) as per TU 3612-023-00220302-00

1.	Designation		
2.	Design and operation conditions Medium parameters	In tubes	In shell
2.1.	Pressure, MPa P operating P design		
2.2.	Operating temperature, °C Outlet Inlet		
2.3.	Design temperature, °C		
2.4.	Minimum permissible (below freezing point) temperature of wall of heat exchanger which is under pressure, °C		
2.5.	Average air temperature of the coldest 5 days at heat exchanger installation site, °C (to be completed for heat exchangers which are installed outdoors or at unheated areas)		
2.6.	Boiling temperature of working medium at pressure 907 MPa, °C		
2.7.	Working medium description and per cent composition		
2.8.	Medium physical condition (gas, steam, liquid)		
2.9.	Working medium characteristics: - Hazard as per GOST 12.1.007 (including hazard class) - Ignition characteristic as per GOST 12.1.004 "yea", "no" - Explosion hazard as per GOST 12.1.011 (including category and group of mixture) - Does medium cause corrosion cracking? "Yes", "No". If "yes" - to be tested		
3.	Material of gaskets		
4.	Necessity of thermal insulating fixing components installation "yes", "no" (delete as appropriate) (components are installed for heat exchangers with shell diameter $\geq 500$ mm)		
5.	Necessity of base metal and welded joint intergranular corrosion testing "yes", "no"; if "yes" - specify the procedure as to GOST 6032, to be completed for heat exchangers made of steel of 08X18H10T; 12X18H10T; 10X17H13M2T; 08X22H6T grades		
6.	Specify: "Left", "right" hinges, "not required" (delete as appropriate). (Hinge devices are installed on horizontal heat exchangers $\varnothing 400-800$ mm at PN $\leq 6.3$ MPa, $\varnothing 1400$ mm at PN $\leq 2.5$ MPa)		
7.	Horizontal heat exchangers are installed: "on concrete base", "steelworks" (delete as appropriate)		
8.	Specify type of tubes fixing in tube sheets: "expansion", "seal welding with expansion" (delete as appropriate)		
9.	Seamless tubes "yes", "no" (delete as appropriate)		
10.	Drawing of heat exchanger with location dimensions of nozzles and supports (specified for heat exchangers, having differences from valid Specifications TU)		
Nozzles			
	Nozzle number as to drawing	Nozzles purpose	Nominal pressure, MPa
		Nozzles DN, mm	
Notes: 1. Drawing is given in accordance with valid Specifications TU. 2. Dimensions should be specify when they differ from those which are specified in valid Specifications TU. 3. Nominal diameters of nozzles are specified when they are smaller than in valid Specifications TU			
11.	Description of specified differences from heat exchanger prototype (differences, listed in valid Specifications are allowed)		

Order form for manufacturing of heat exchanger as to Specifications TU 3612-023-00220302-00 is not to be agreed.

Name of Customer Company and process unit or line \_\_\_\_\_  
 Name and postal address of the Company which completed the order form \_\_\_\_\_  
 Head of the Company which completed the order form \_\_\_\_\_

\_\_\_\_\_  
(Title)

\_\_\_\_\_  
(signature)

\_\_\_\_\_  
(printed name)

\_\_\_\_\_  
(date)



# 61 Oil Coolers of MO-53-4 Type

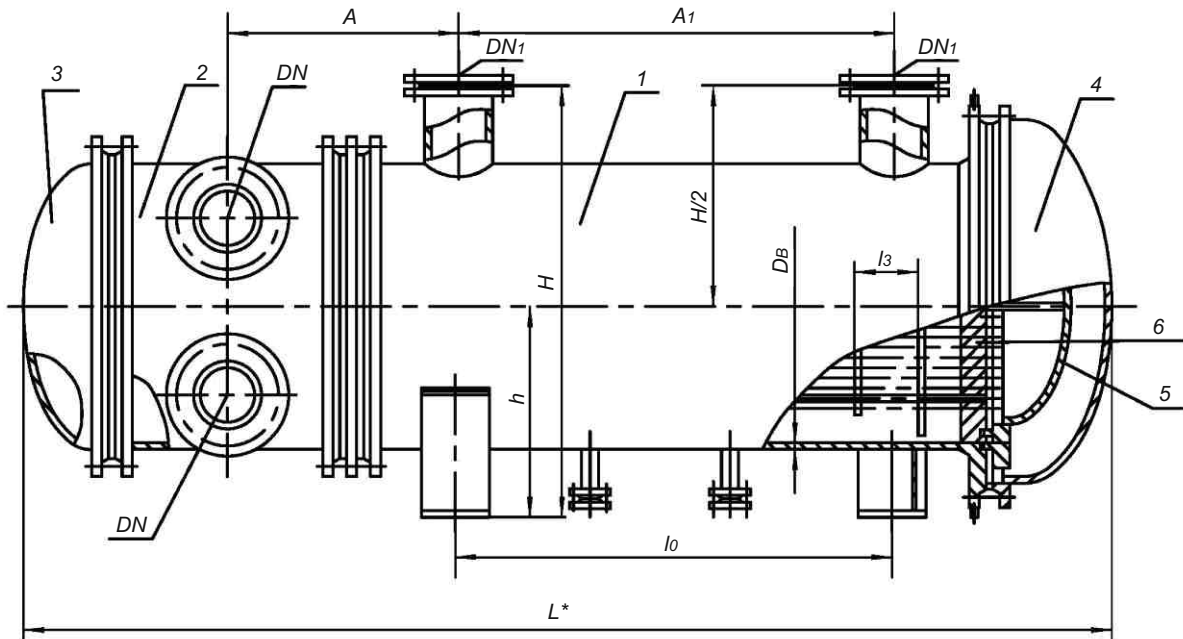

1 - shell; 2 - chamber; 3 - cover; 4 - cover; 5 - cover; 6 - tube-sheet

Oil coolers basic dimensions, mm

Shell inner diameter $D_i$	Pressure PN, MPa, max	$L^*$	Tubes length $l$	$l_o$	Partition walls layout		$H$	$H/2$	$h$	DN at number of passes through tubes	$DN_1$	$A$	$A_1$
					$l_3$	Number							
700	0.4	2660	1868	1370	88	19	1145	615	530	150	150	350	1450

Oil coolers basic parameters

Parameter	Parameter value	
Heat exchange surface, $m^2$	53	
Shell diameter, mm, inner	700	
Design temperature, $^{\circ}C$	In tubes	40
	In shell	95
Design pressure, MPa, in shell	0.4	
Design pressure, MPa, in tubes	0.4	
Length of heat exchange tube straight run, mm	1868	
Outer diameter and wall thickness of heat exchanging tubes (diameter and wall thickness), mm	16x1	
Number of passes through tubes	4	
Layout of heat exchanging tubes in tube sheets and partition walls	At equilateral triangles corners	



Material								
Shell and cover	Distributing chamber and cover	Heat exchanging tubes	Tube sheet	Partition wall	Shell gaskets	Distributing chamber gaskets	Floating head gasket	Weight, kg
Steel Ст 12X18H10T M26 as to GOST 5632	Titanium BT1-0 as to GOST 19807-74	Titanium BT1-0 as to OST 1-90050-72	Titanium BT1-0 as to GOST 19807-74	Steel Ст 12X18H10T-M26 as to GOST 5632-72	Compressed asbestos fibre sheets as to GOST 481-80		Compressed asbestos fibre sheets as to GOST 481-80	1460
Steel Ст3пс5 as to GOST 380-94; Forgings Ст20 Gr.IV КП195 as to GOST 8479	Steel Ст3пс5 as to GOST 380-94; steel Ст 20K as to GOST 5520-79	Cupronickel alloy МНЖ5-1 as to GOST 17217-79	Steel Ст 20K-5 as to GOST 5520-79	Steel Ст3пс5 as to GOST 380-94	Compressed asbestos fibre sheets as to GOST 481-80		Compressed asbestos fibre sheets as to GOST 481-80	1850
Titanium BT1-0 as to GOST 19807-74	Titanium BT1-0 as to GOST 19807-74	Titanium BT1-0 as to OST 1-90050-72	Titanium BT1-0 as to GOST 19807-74	Titanium BT1-0 as to GOST 19807-74	Compressed asbestos fibre sheets as to GOST 481-80		Compressed asbestos fibre sheets as to GOST 481-80	1042
Steel Ст 08X18H10T-M26 as to GOST 5632-72	Steel Ст 08X18H10T-M26 as to GOST 5632-72	Steel Ст 08X18H10T as to GOST 9941-81	Steel Ст 12X18H10T-M26 as to GOST 5632-72	Steel Ст 08X18H10T-M26 as to GOST 5632-72	Compressed asbestos fibre sheets as to GOST 481-80		Compressed asbestos fibre sheets as to GOST 481-80	1850



# Heat Exchangers

**Shell and Tube Heat Exchangers with Fixed Sheets  
and Shell and Tube Heat Exchangers with Expansion Pipe  
on Shell as to Specification TU 3612-024-002203002-02**





These heat exchangers are designed for heating and cooling of liquid and gaseous media in processing of oil refining, petrochemical, chemical, oil, gas industry.

Heat exchangers are classified by:

Purpose - heat exchangers (T), coolers (Kh), condensing apparatus (K), vaporizers (I);

Design - heat exchangers with fixed tube sheets (N type), with expansion pipe on shell (K type);

Location - horizontal (G), vertical (V).

Smooth-walls tubes are applied in the heat exchangers (G).

These heat exchangers can be operated in temperate and tropical climatic conditions.

Climatic design "U" and "T", item category 1 according to GOST 15150.

The heat exchangers are designed for installation in geographic areas with seismicity up to 7 points on the highest 12-point scale.

Technical requirements to materials, manufacture, acceptance, testing methods and preservation of apparatuses per SOU MPP 71.120-217:2009, GOST R 52630 and Technical Regulation of Customs Union 032/2013.

Depending on operation temperature limits heat exchangers can be manufactured of the following design:

- N – low-temperature from - 30 up to +100°C;
- N1 – low-temperature from - 40 up to +100°C;
- N2 – low-temperature from - 60 up to +100°C;
- N3 – low-temperature from - 70 up to +100°C;
- O – normal from -20 up to +100°C;
- S – average from -20 up to +200°C;
- V – high-temperature from - 20 up to +300°C;
- V1 – high-temperature from - 20 up to +350°C.

### The example of designation:

Heat exchanger (T) with fixed tube sheets (N), shell diameter 600 mm, horizontal (G), nominal pressure in tubes and shell 1.6 MPa, material version M1, temperature limit design "O", with plain heat-transferring tubes (G) of 25 mm diameter and 6 m length, 2-passes through tube side, climatic version (U), with components for heat-insulator fixing of group 4:

**Heat exchanger 600TNG-1.6-M1-O/25G-6-2-U-I gr.4**

**Specifications TU 3612-024-00220302-02**

Heat exchanger (T) with expansion pipe on shell, shell diameter 600 mm, vertical (V), nominal pressure 1.6 MPa, material version M1, temperature limit design "O", with plain heat-transferring tubes (G) of 25 mm diameter and 8 m length, 2-passes through tube side, climatic version (T), without components for heat-insulator fixing of group 4:

**Heat exchanger 600 TKV-1.6-M1-O/25G-6-2-T gr.4**

**Specifications TU 3612-024-00220302-02**

Vaporizer (I) with fixed tube sheets (N), shell diameter 600 mm, design 1, nominal pressure in tubes 1.0 MPa and in shell 1.6 MPa, material version M1, temperature limit design "V", with plain heat-transferring tubes (G) of 25 mm diameter and 4 m length, climatic version (U), with components for heat-insulator fixing of group 3:

**Vaporizer 600 IN-1-1.0-1.6-M1-V/25G-4-U-I gr.3**

**Specifications TU 3612-024-00220302-02**

Heat exchangers should be ordered in accordance with Data Sheets.



# Shell and Tube Heat Exchangers with Fixed Sheets and Shell and Tube Heat Exchangers with Expansion Pipe on Shell as to Specification TU 3612-024-002203002-02

Parameter		Parameter designation for heat exchanger							
		TN	TK	KhN	KhK	KN	KK	IN	IK
Temperature of heat-transferring medium, °C±5°C	In shell	From - 70 up to + 350							
	In tubes								
Nominal pressure in shell for heat exchangers with diameter 159, 273, 325 mm, MPa, max	400 mm	1.6; 2.5; 4.0	1.6	1.0; 1.6; 2.5; 4.0	1.0; 1.6	-	-	-	-
	600 mm	1.0; 1.6; 2.5; 4.0	1.0; 1.6	1.0; 1.6; 2.5; 4.0	1.0; 1.6	1.0; 1.6; 2.5	1.0; 1.6; 2.5; 4.0	1.0; 1.6	1.0; 1.6
	800 mm	0.6; 1.0; 1.6; 2.5; 4.0	0.6; 1.0; 1.6	0.6; 1.0; 1.6; 2.5; 4.0	0.6; 1.0; 1.6	0.6; 1.0; 1.6; 2.5	0.6; 1.0; 1.6; 2.5	0.6; 1.0; 1.6; 2.5	0.6; 1.0; 1.6
	1000 mm	0.6; 1.0; 1.6; 2.5	0.6; 1.0; 1.6	0.6; 1.0; 1.6; 2.5	0.6; 1.0; 1.6	0.6; 1.0; 1.6; 2.5	0.6; 1.0; 1.6; 2.5	0.6; 1.0; 1.6; 2.5	0.6; 1.0; 1.6
	1200 mm	1.6; 2.5; 4.0	1.6	1.6; 2.5; 4.0	1.6	-	-	-	-
Nominal pressure in tubes for heat exchangers with diameter 159, 273, 325 mm, MPa, max	400 mm	1.0; 1.6; 2.5; 4.0	1.0; 1.6	1.0; 1.6; 2.5; 4.0	1.0; 1.6	0.6	0.6	0.6; 1.0	0.6; 1.0
	600 mm	0.6; 1.0; 1.6; 2.5; 4.0	0.6; 1.0; 1.6	0.6; 1.0; 1.6; 2.5; 4.0	0.6; 1.0; 1.6	0.6; 1.0; 1.6; 2.5	0.6; 1.0; 1.6; 2.5	0.6; 1.0; 1.6; 2.5	0.6; 1.0; 1.6
	800 mm	0.6; 1.0; 1.6; 2.5	0.6; 1.0; 1.6	0.6; 1.0; 1.6; 2.5	0.6; 1.0; 1.6	0.6; 1.0; 1.6; 2.5	0.6; 1.0; 1.6; 2.5	0.6; 1.0; 1.6; 2.5	0.6; 1.0; 1.6
	1000 mm	20x2 25x2	20x2 25x2	20x2 25x2	20x2 25x2	20x2 25x2	20x2 25x2	20x2 25x2	20x2 25x2
Outer diameter and thickness of walls of heat-transferring tubes, mm	159, 273 mm	1	1	-	1	-	-	-	-
	325 mm	1.2	1.2	-	2	-	-	-	-
	400 mm	1.2	1.2	-	2	-	-	-	-
Number of passes through tubes for heat exchangers with the diameter	600, 800, 1000, 1200 mm	1; 2; 4	1; 2; 4	2; 4	2; 4	2; 4; 6	2; 4; 6	2; 4; 6	1



Heat exchangers of TNG, TKG, KhNG, KhKG types with one pass through tubes

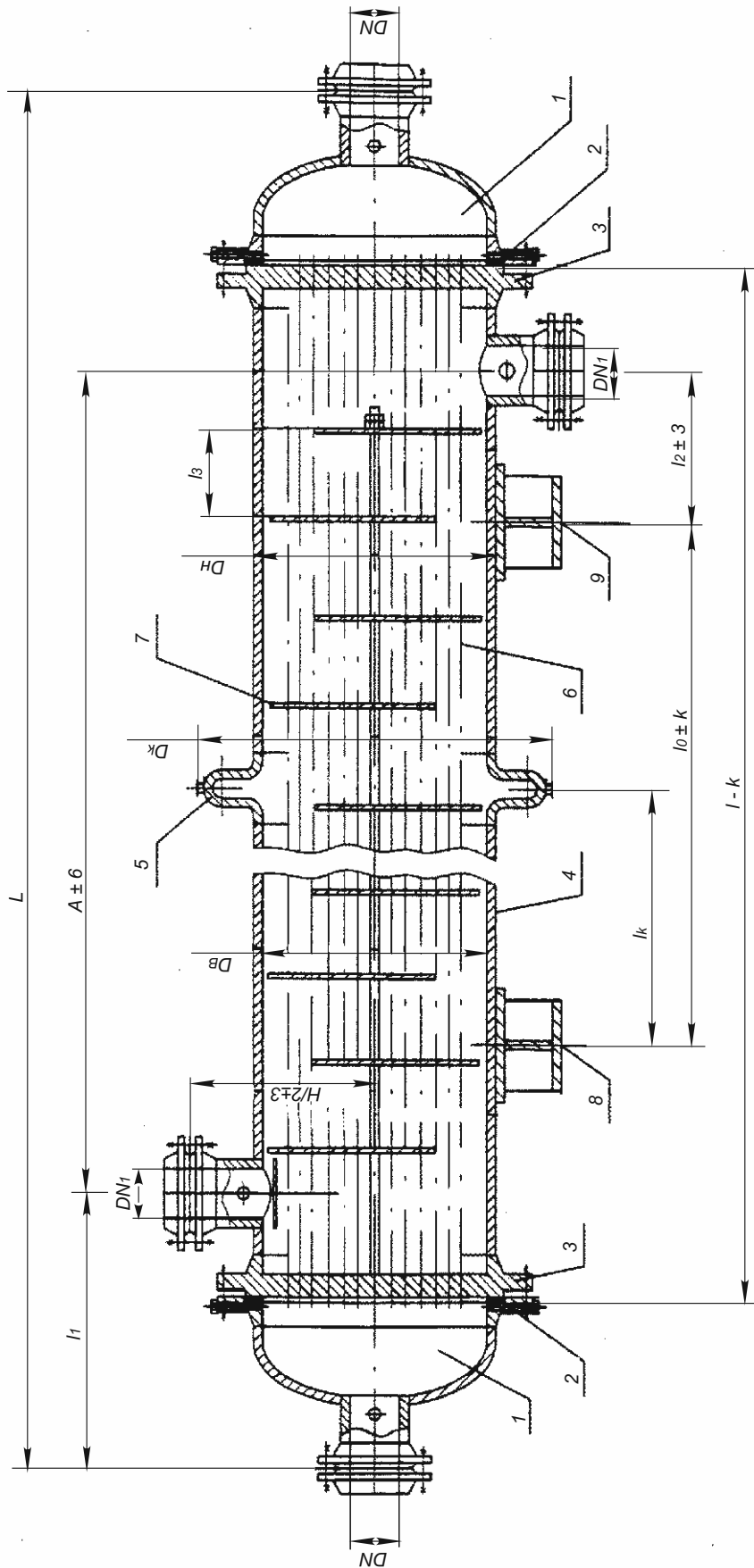

1- distributing chamber; 2 - distributing chamber gasket; 3 - tube sheet; 4 - shell; 5 - expansion pipe; 6 - heat-transferring tube; 7 - partition wall; 8 - fixed support; 9 - removable support; 10 - shell gasket; 11 - shell cover.

**Notes:**

1. The draw does not specify heat exchanger design.
2.  $k=5$  mm, if the length of tubes  $\leq 3000$  mm and  $k=10$ , if the length of tubes  $> 3000$  mm.
3. Dimensions  $l_1$ ,  $L$ ,  $l_k$ ,  $D_k$  are recommended, specified at detailed documentation development.

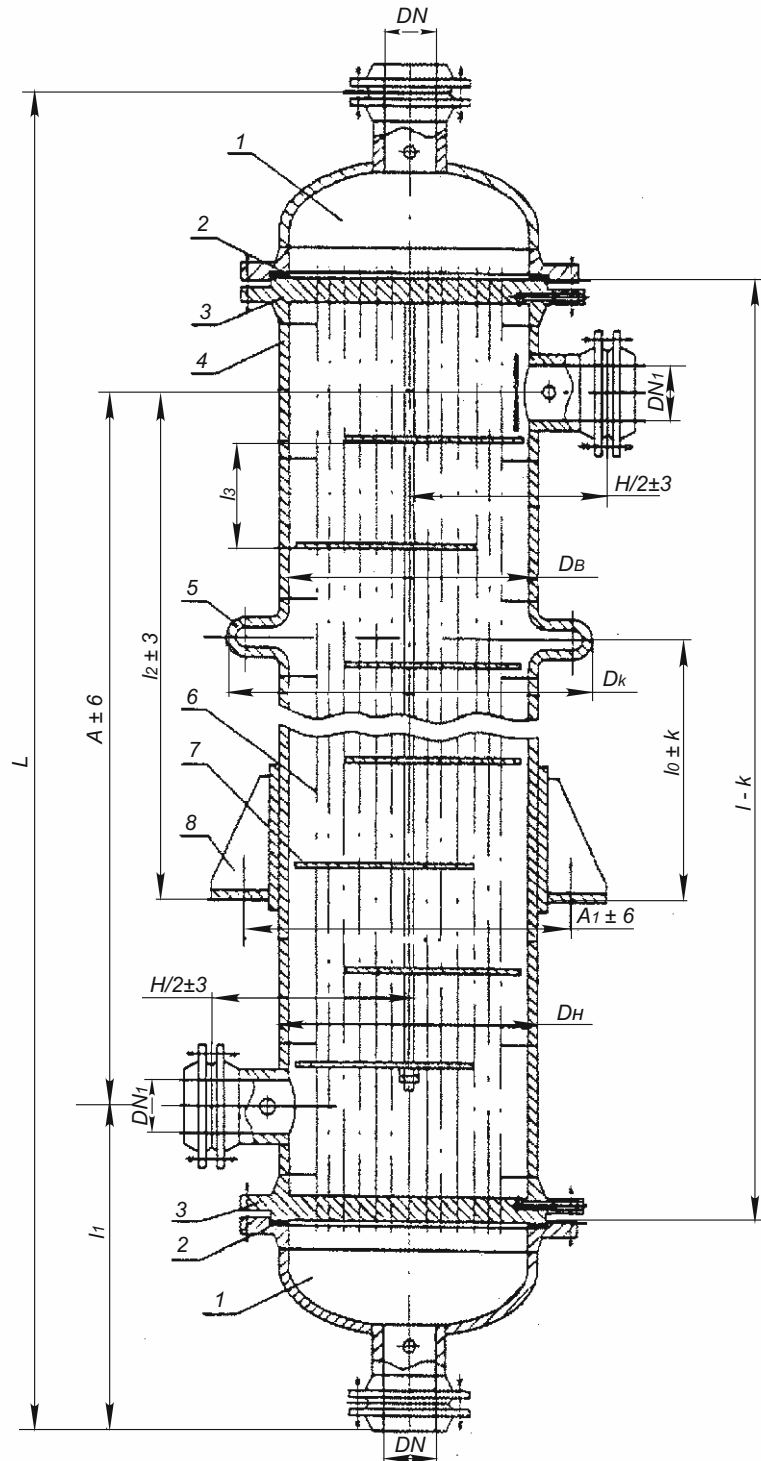

1- distributing chamber; 2 - distributing chamber gasket; 3 - tube sheet; 4 - shell; 5 - expansion pipe; 6 - heat-transferring tube; 7 - partition wall; 8 - removable support

#### Notes:

1. The draw does not specify heat exchanger design.
2.  $k=5$  mm, if the length of tubes  $\leq 3000$  mm and  $k=10$ , if the length of tubes  $> 3000$  mm.
3. Dimensions  $l_1$ ,  $L$ ,  $l_k$ ,  $D_k$  are recommended, specified at detailed documentation development.



Multi-pass through tubes heat exchangers of TNG, TKG types

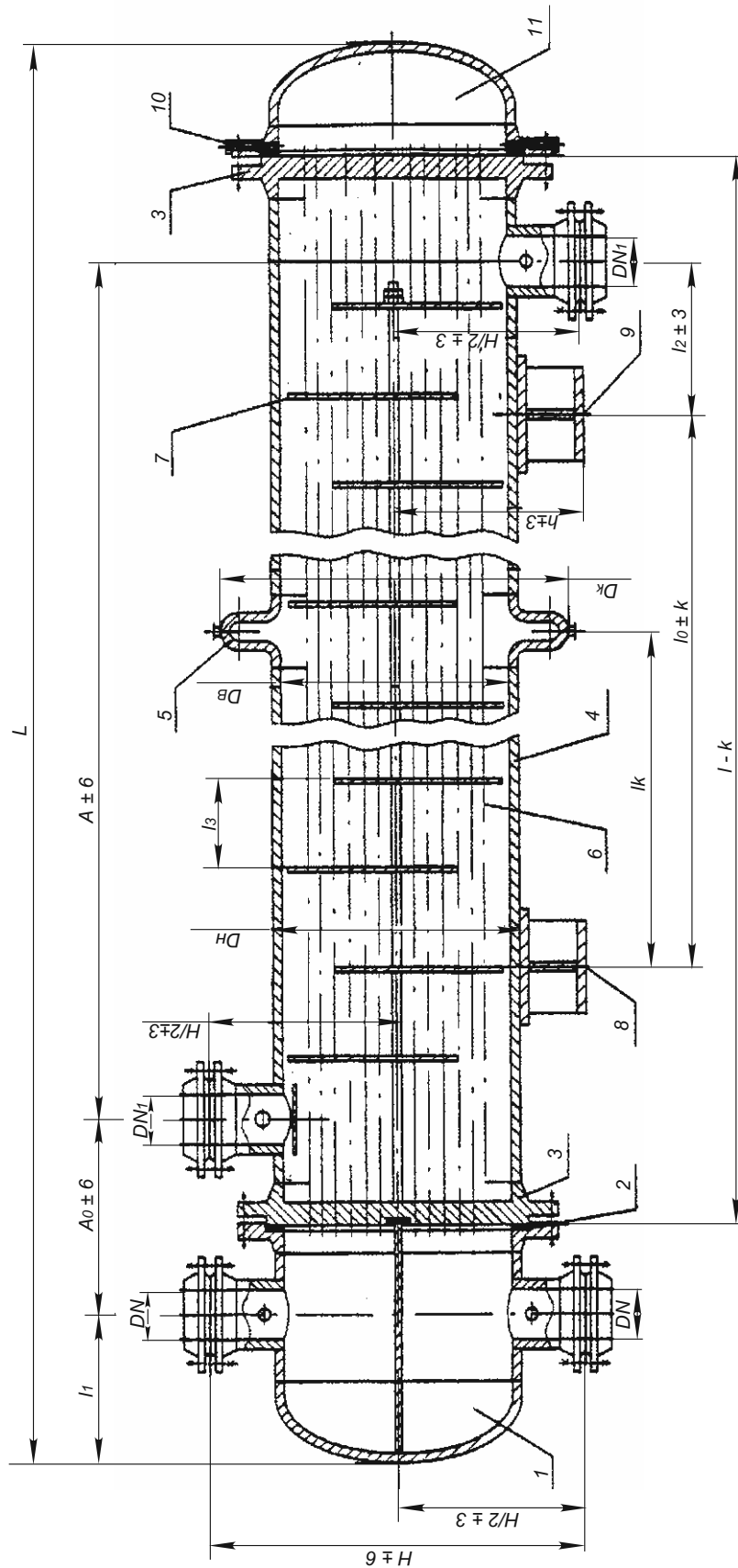

1- distributing chamber; 2 - distributing chamber gasket; 3 - tube sheet; 4 - shell; 5 - expansion pipe; 6 - heat-transferring tube; 7 - partition wall; 8 - fixed support; 9 - removable support; 10 - shell gasket; 11 - shell cover.

Notes:

1. The draw does not specify heat exchanger design.
2.  $k=5$  mm, if the length of tubes  $\leq 3000$  mm and  $k=10$ , if the length of tubes  $> 3000$  mm.
3. Dimensions  $l_1$ ,  $L$ ,  $l_k$ ,  $D_k$  are recommended, specified at detailed documentation development.



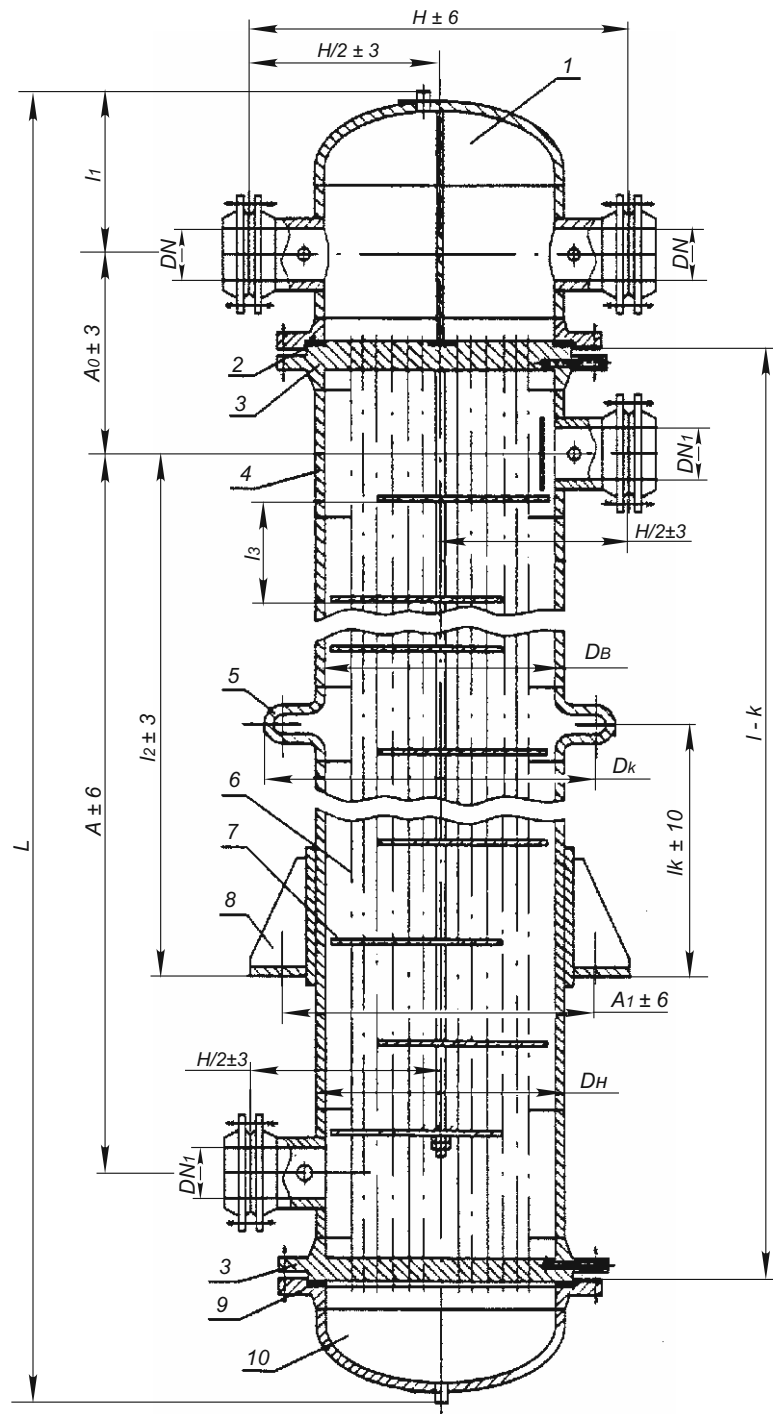

1- distributing chamber; 2 - distributing chamber gasket; 3 - tube sheet; 4 - shell; 5 -expansion pipe;  
6 - heat-transferring tube; 7- partition wall; 8 -removable support; 9 - shell gasket; 10 - shell cover

**Notes:**

1. The draw does not specify heat exchanger design.
2.  $k=5$  mm, if the length of tubes  $\leq 3000$  mm and  $k=10$ , if the length of tubes  $> 3000$  mm.
3. Dimensions  $l_1$ ,  $L$ ,  $l_k$ ,  $D_k$  are recommended, specified at detailed documentation development.



Basic parameters of heat exchangers of TN and TK types

Dimensions, mm																						
Shell diameter, outer	Pressure in shell and tubes PN, MPa	l	L, max. at number of passes through tubes		l <sub>0</sub>	A	DN at number of passes through tubes		DN1	Dk	H/2	h	A <sub>0</sub>	l <sub>1</sub>		l <sub>2</sub>		l <sub>k</sub>		Partition wall location		
			1	2			1	2						TNG TKG	TNV TKV	TKG	TKV	l <sub>3</sub>	Number			
159	1.6; 2.5; 4.0 <sup>1)</sup>	1000	1400	-	350	620	80	-	80	309 <sup>2)</sup>	215	159	-	2	1	2	200	400	-	-	6	6
		1500	1900	-	650	1120	-	-	-	-	-	-	-	-	-	-	400	800	325 <sup>2)</sup>	400 <sup>2)</sup>	10	10
		2000	2400	-	800	1620	-	-	-	-	-	-	-	-	-	-	500	1200	400 <sup>2)</sup>	400 <sup>2)</sup>	14	14
		3000	3400	-	1500	2620	-	-	-	-	-	-	-	-	-	-	650	1500	750 <sup>2)</sup>	750 <sup>2)</sup>	26	26
273	1.6	1000	1450	-	350	600	-	-	-	423	-	-	-	-	-	250	400	-	-	4	4	
		1500	1950	-	650	1100	-	-	-	-	-	-	-	-	-	350	800	325	450	8	8	
		2000	2450	-	800	1600	-	-	-	-	-	-	-	-	-	500	1200	400	700	12	12	
		3000	3450	-	1500	2600	-	-	-	-	-	-	-	-	-	650	1500	750	900	20	20	
	1000	1500	-	350	570	100	-	100	-	-	272	241	-	-	465	-	250	400	-	-	4	4
	1500	2000	-	650	1070	-	-	-	-	-	-	-	-	-	465	-	350	800	-	-	8	8
	2000	2500	-	800	1570	-	-	-	-	-	-	-	-	-	465	-	500	1200	-	-	12	12
	3000	3500	-	1500	2570	-	-	-	-	-	-	-	-	-	465	-	650	1500	-	-	20	20
325	1.6; 2.5 <sup>1)</sup>	1000	1550	-	350	520	-	-	-	-	-	-	-	-	-	250	400	-	-	4	4	
		1500	2050	-	650	1020	-	-	-	-	-	-	-	-	-	350	800	325 <sup>2)</sup>	475 <sup>2)</sup>	6	6	
		2000	2550	-	800	1520	-	-	-	-	-	-	-	-	-	500	1200	400 <sup>2)</sup>	700 <sup>2)</sup>	8	8	
		3000	3550	-	1500	2520	-	-	-	-	-	-	-	-	-	650	1500	750 <sup>2)</sup>	900 <sup>2)</sup>	14	14	
	1500	2200	2170	650	1050	100	100	100	475 <sup>2)</sup>	-	298	290	-	440	575	220	350	800	325 <sup>2)</sup>	475 <sup>2)</sup>	175	6
	2000	2700	2670	800	1550	-	-	-	-	-	-	-	-	-	575	-	500	1200	400 <sup>2)</sup>	700 <sup>2)</sup>	8	8
	3000	3700	3670	1500	2550	-	-	-	-	-	-	-	-	-	575	-	650	1500	750 <sup>2)</sup>	900 <sup>2)</sup>	14	14
	4000	4700	4670	2000	3550	-	-	-	-	-	-	-	-	-	575	-	800	1800	1000 <sup>2)</sup>	1000 <sup>2)</sup>	20	20
1500	2250	2170	650	990	100	100	100	-	-	-	-	-	490	630	-	350	800	-	-	6	6	
2000	2750	2670	800	1490	-	-	-	-	-	-	-	-	-	630	-	500	1200	-	-	8	8	
3000	3750	3670	1500	2490	-	-	-	-	-	-	-	-	-	630	-	650	1500	-	-	14	14	
4000	4750	4670	2000	3490	-	-	-	-	-	-	-	-	-	630	-	800	1800	-	-	20	20	



Continuation sheet

Dimensions, mm										Partition wall location															
Shell diameter, mm	Pressure in shell and tubes PN, MPa	l	L, max. at number of passes through tubes		l <sub>0</sub>	A	DN at number of passes through tubes			DN <sub>1</sub>	D <sub>k</sub>	H/2	h	A <sub>0</sub>	l <sub>0</sub>		l <sub>2</sub>		l <sub>k</sub>		l <sub>3</sub>	Number			
			1	2; 4 <sup>4)</sup>			1	2	4						2; 4 <sup>4)</sup>	1	2; 4 <sup>4)</sup>	TNG TKG	TNV TKV	TKG			TKV		
400 426 <sup>3)</sup>	1.6; 2.5 <sup>1)</sup>	2000	2790	2770	800	1550	150	150	150	150	562 <sup>2)</sup>	363	349	460	620	280	500	1200	400 <sup>2)</sup>	700 <sup>2)</sup>	6	6	250	6	
		3000	3790	3770	1500	2550											500	1500	750 <sup>2)</sup>	900 <sup>2)</sup>	10	10		10	10
		4000	4790	4770	2000	3550											800	1800	1000 <sup>2)</sup>	1000 <sup>2)</sup>	14	14		14	14
		6000	6790	6770	3000	5550											1200	1800	1500 <sup>2)</sup>	1000 <sup>2)</sup>	22	22		22	22
600 630 <sup>3)</sup>	4.0	2000	2820	2810	800	1440	150	150	150	150	-			690			500	1200			6	6	250	6	
		3000	3820	3810	1500	2440											500	1500			10	10		10	10
		4000	4820	4810	2000	3440											800	1800			14	14		14	14
		6000	6820	6810	3000	5440											1200	1800			22	22		22	22
600 630 <sup>3)</sup>	1.6	2000	2940	2910	800	1500					762			520	370		400	1200	400	700	4	4	250	4	
		3000	3940	3910	1500	2500											500	1500	750	900	8	8		8	8
		4000	4940	4910	2000	3500											800	1800	1000	1000	10	10		10	10
		6000	6940	6910	3000	5500											1200	1800	1500	1000	18	18		18	18
600 630 <sup>3)</sup>	2.5	2000	2950	2950	800	1450	200	200	200	200		530	525	545	750		400	1200			4	4	250	4	
		3000	3950	3950	1500	2450											500	1500			8	8		8	8
		4000	4950	4950	2000	3450											800	1800			10	10		10	10
		6000	6950	6950	3000	5450											1200	1800			18	18		18	18
800	4.0	2000	3060	3020	800	1400	250	250	250	250				600	830		400	1200			4	4	250	4	
		3000	4060	4020	1500	2400											500	1500			8	8		8	8
		4000	5060	5020	2000	3400											800	1800			10	10		10	10
		6000	7060	7020	3000	5400											1200	1800			18	18		18	18
800	1.0	2000	3070	3160	800	1450	250	250	250	250	962	627	608	630	810		400	1200	400	700	4	4	250	4	
		3000	4070	4160	1500	2450											600	1500	750	900	6	6		6	6
		4000	5070	5160	2000	3450											800	1800	1000	1000	8	8		8	8
		6000	7070	7160	3000	5450											1200	1800	1500	1000	14	14		14	14





Continuation sheet

Dimensions, mm																								
Shell diameter, inner	Pressure in shell and tubes, MPa	l	L, max. at number of passes through tubes		l <sub>0</sub>	A	DN at number of passes through tubes			DNr	D <sub>k</sub>	H/2	h	A <sub>0</sub>	I <sub>1</sub>		I <sub>2</sub>		I <sub>k</sub>		Partition wall location			
			1	2; 4			1	2	4						At number of passes through tubes	2; 4	1	2; 4	TNG TKG	TNV TKG	TKG	TKV	I <sub>3</sub>	Number
800	1.6	2000	3140	3190	800	1410								2; 4	1	2; 4	400	1200	400	700			4	
		3000	4140	4190	1500	2410					962	608		650	865	440	600	1500	750	900			6	
		4000	5140	5190	2000	3410												800	1800	1000	1000			8
		6000	7140	7190	3000	5410												1200	1800	1500	1000			14
800	2.5	2000	3220	3225	800	1400											400	1200					4	
		3000	4220	4225	1500	2400				250				655	910	450	600	1500				350		6
		4000	5220	5225	2000	3400												800	1800					8
		6000	7220	7225	3000	5400												1200	1800					14
800	4.0	2000	3430	3290	800	1300											400	1200					4	
		3000	4430	4290	1500	2300								700	1065	460	600	1500						6
		4000	5430	5290	2000	3300												800	1800					8
		6000	7430	7290	3000	5300												1200	1800					14
1000	0.6;	3000	4210	4220	1500	2350											400	1500					4	
		4000	5210	5220	2000	3350												600	1800					6
	1.0	6000	7210	7220	3000	5350									930			1200	1800					10
		9000	10210	10220	6000	8350												1200	1800					16
1000	1.6	3000	4270	4240	1500	2350											400	1500					4	
		4000	5270	5240	2000	3350												600	1800					6
		6000	7270	7240	3000	5350												1200	1800					10
		9000	10270	10240	6000	8350												1200	1800					16
1000	2.5	3000	4390	4300	1500	2300											400	1500					4	
		4000	5390	5300	2000	3300												600	1800					6
		6000	7390	7300	3000	5300												1200	1800					10
		9000	10390	10300	6000	8300												1200	1800					16



Dimensions, mm										Continuation sheet													
Shell diameter, inner	Pressure in shell and tubes, MPa	l	L, max. at number of passes through tubes		l <sub>0</sub>	A	DN at number of passes through tubes			DN <sub>1</sub>	D <sub>k</sub>	H/2	h	A <sub>0</sub>	I <sub>1</sub>		I <sub>2</sub>			I <sub>k</sub>		Partition wall location	
			1	2; 4			1	2	4						At number of passes through tubes	2; 4	TNG	TNW	TKG	TKV	I <sub>3</sub>		Number
1000	4.0	3000	4580	4420	1500	2200	300	300	200	300	-	779	716	800	1	2; 4	400					520	4
		4000	5580	5420	2000	3200	3200	300	300	200				800	1190	550	600						6
		6000	7580	7420	3000	5200	5200							1200			1200						10
1200	0.6; 1.0	4000	5300	5400	2000	3200						812					700						6
		6000	7300	7400	3000	5200	5200						812		1050		1200	1500					8
		9000	10300	10400	6000	8200	8200				1362	831		765		600	1200				1000		14
	4000	5400	5420	2000	3200	3200	350	350	250						1100		700					6	
	6000	7400	7420	3000	5200	5200	350	350	250						1100		1200					8	
	9000	10400	10420	6000	8200	8200							822	800	1170	1200	1200					550	14
1200	2.5	4000	5540	5500	2000	3200								800	1170	620	700	1800					6
		6000	7540	7500	3000	5200	5200					879				620	1200						8
		9000	10540	10500	6000	8200	8200								800	1170	1200	1200					14

- 1) Heat exchangers designed for operation at nominal pressure PN 1.6; 2.5 and 4.0 MPa, differ by flanges, which are mounted on nominal pressure PN 1.6; 2.5 and 4.0 MPa.
- 2) Apply only for heat exchangers with nominal pressure PN 1,6 MPa .
- 3) Outer shell diameter (at tube manufacturing).
- 4) Apply 4-pass through tubes heat exchangers for units with shell diameter > 600 (630) mm.



## Multi-pass through tubes heat exchangers of KhNG, KhKG types

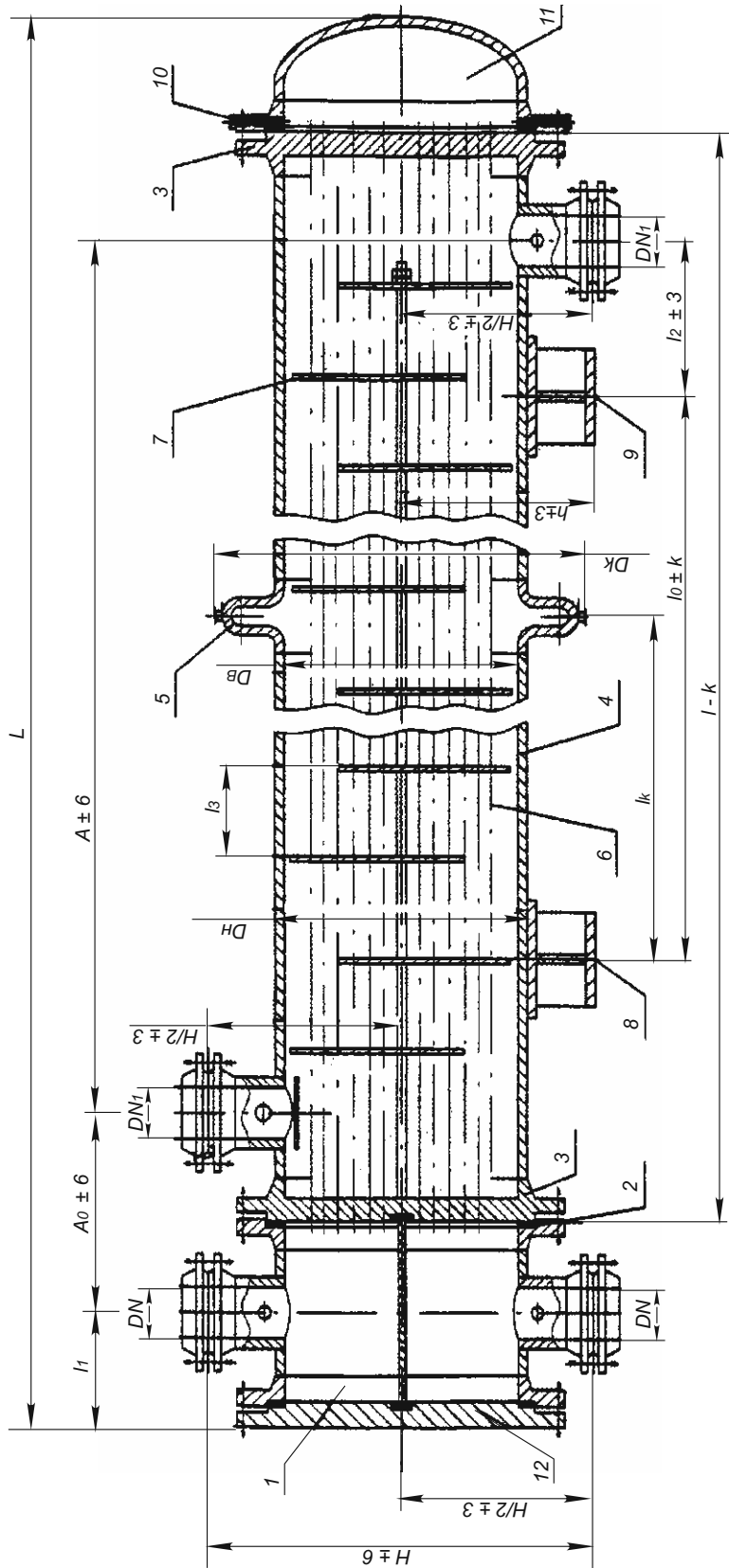

1- distributing chamber; 2 - distributing chamber gasket; 3 - tube sheet; 4 - shell; 5 - expansion pipe; 6 - heat-transferring tube; 7 - partition wall; 8 - fixed support; 9 - removable support; 10 - shell gasket; 11 - shell cover; 12 - distributing chamber cover.

## Notes:

1. The draw does not specify heat exchanger design.
2.  $k=5$  mm, if the length of tubes  $\leq 3000$  mm and  $k=10$ , if the length of tubes  $> 3000$  mm.
3. Dimensions  $l_1$ ,  $L$ ,  $l_k$ ,  $D_k$  are recommended, specified at detailed documentation development.

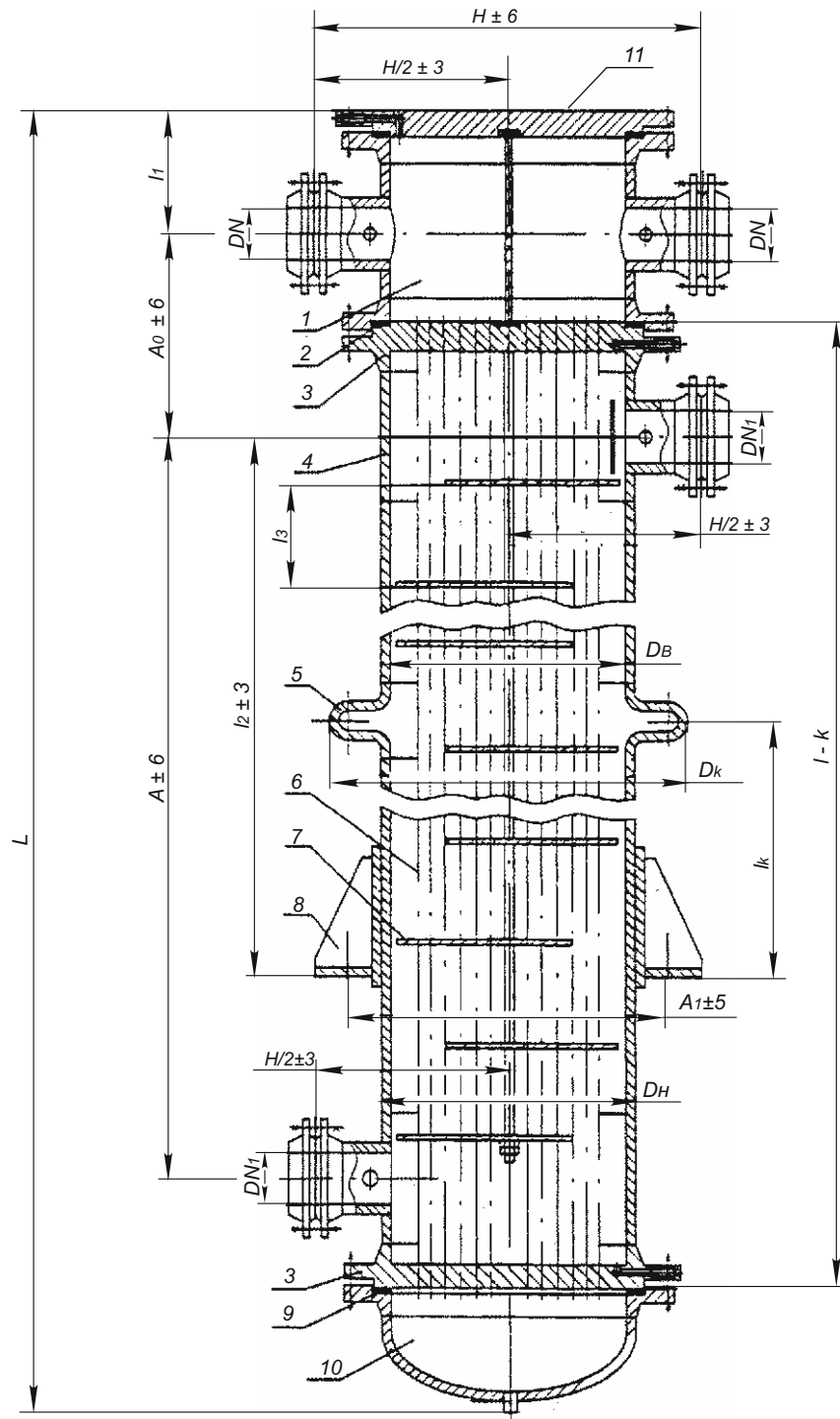

1 - distributing chamber; 2 - distributing chamber gasket; 3 - tube sheet; 4 - shell; 5 - expansion pipe; 6 - heat-transferring tube; 7 - partition wall; 8 - removable support; 9 - shell gasket; 10 - shell cover; 11 - distributing chamber cover

**Notes:**

1. The draw does not specify heat exchanger design.
2.  $k=5$  mm, if the length of tubes  $\leq 3000$  mm and  $k=10$ , if the length of tubes  $> 3000$  mm.
3. Dimensions  $l_1$ ,  $L$ ,  $l_k$ ,  $D_k$  are recommended, specified at detailed documentation development.



Basic parameters of heat exchangers of KhN and KhK types

Dimensions, mm																								
Shell diameter, outer	Pressure in shell PN, MPa	l	L, max. at number of passes through tubes		l <sub>0</sub>	A	DN at number of passes through tubes			DN <sub>r</sub>	D <sub>k</sub>	H/2	h	A <sub>0</sub>		l <sub>1</sub>		l <sub>2</sub>			l <sub>k</sub>		Partition wall location	
			1	2; 4 <sup>1)</sup>			1	2	4					1	2; 4 <sup>1)</sup>	2; 4 <sup>1)</sup>	1	2; 4 <sup>1)</sup>	KhNG NKG	KhNV KhKV	KhKG	KhKV	l <sub>3</sub>	Number
159	1.6	1500	1900		650	1120									2; 4 <sup>1)</sup>			400	800	325	400			10
		2000	2400		800	1620		80	-	80	309	215	159		-	390		500	1200	400	400		100	14
		3000	3400		1500	2620												650	1500	750	750			26
273	1.6	1500	1950		650	1100												350	800	325	450			8
		2000	2450		800	1600		100	-	100	423	272	241		-	425		500	1200	400	700		125	12
		3000	3450		1500	2600												650	1500	750	900			20
325	1.6	1500		2170	650	1050												350	800	325	475			6
		2000		2670	800	1550												500	1200	400	700			8
		3000		3670	1500	2550												650	1500	750	900			14
400 426 <sup>2)</sup>	1.6	2000		4670	650	3550												800	1800	1000	1000			20
		3000		2720	800	1550												500	1200	400	700			6
		4000		3720	1500	2550												500	1500	750	900			10
600 630 <sup>2)</sup>	1.0; 1.6 <sup>3)</sup>	2000		4720	650	3550												800	1800	1000	1000			22
		3000		6720	3000	5550												1200	1800	1500	1000			4
		4000		2900	800	1500												400	1200	400	700			8
600 630 <sup>2)</sup>	2.5	2000		3900	800	1450												500	1500	750	900			4
		3000		4900	2000	3500												500	1500	750	900			8
		4000		6900	3000	5500												800	1800	1000	1000			10
600 630 <sup>2)</sup>	2.5	2000		2910	800	1450												400	1200	400	700			4
		3000		3910	1500	2450												500	1500	750	900			8
		4000		4910	2000	3450												800	1800	1000	1000			10
600 630 <sup>2)</sup>	2.5	2000		6910	3000	5450												1200	1800	1500	1000			18
		3000		2910	800	1450												400	1200	400	700			4
		4000		3910	1500	2450												500	1500	750	900			8
600 630 <sup>2)</sup>	2.5	2000		4910	2000	3450												800	1800	1000	1000			10
		3000		6910	3000	5450												1200	1800	1500	1000			18
		4000		2910	800	1450												400	1200	400	700			4



Continuation sheet

Shell diameter, inner		Pressure in shell PN, MPa	l	L, max. at number of passes through tubes	l <sub>0</sub>	A	DN at number of passes through tubes		DN <sub>1</sub>	D <sub>k</sub>	H/2	h	A <sub>0</sub>		I <sub>1</sub>	I <sub>2</sub>		I <sub>k</sub>		Partition wall location			
							2	4					2; 4	At number of passes through tubes		KhNG KhKG	KhNV KhKV	KhKG	KhKV	I <sub>3</sub>	Number		
600 630 <sup>(2)</sup>	4.0	2000	2950	800	1400	200	150	200	-	530	525	635	2; 4	2; 4	1200	-	-	300	4	8	10	18	
		3000	3950	1500	2400																		
		4000	4950	2000	3400																		
		6000	6950	3000	5400																		
800	1.0; 1.6 <sup>(3)</sup>	2000	2990	800	1450	250	200	962	627	608	620	620	2; 4	2; 4	400	400	400	700	4	6	8	14	
		3000	3990	1500	2450																		
		4000	4990	2000	3450																		
		6000	6990	3000	5450																		
800	2.5	2000	3000	800	1400	250	200	250	612	645	645	645	2; 4	2; 4	400	600	1200	-	350	4	6	8	14
		3000	4000	1500	2400																		
		4000	5000	2000	3400																		
		6000	7000	3000	5400																		
1000	4.0	2000	3040	800	1350	300	200	1162	677	612	670	670	2; 4	2; 4	400	600	1200	-	520	4	6	8	14
		3000	4040	1500	2350																		
		4000	5040	2000	3350																		
		6000	7040	3000	5350																		
1000	0.6; 1.0 <sup>(3)</sup>	3000	4200	1500	2350	300	200	300	729	712	760	760	2; 4	2; 4	400	600	1200	-	900	4	6	10	16
		4000	5200	2000	3350																		
		6000	7200	3000	5350																		
		9000	10200	6000	8350																		
1000	1.6	3000	4200	1500	2350	300	200	300	729	712	760	760	2; 4	2; 4	400	600	1200	-	900	4	6	10	16
		4000	5200	2000	3350																		
		6000	7200	3000	5350																		
		9000	10200	6000	8350																		

Dimensions, mm



Continuation sheet

Shell diameter, inner		Pressure in shell PN, MPa	l	L, max. at number of passes through tubes		l <sub>0</sub>	A	DN at number of passes through tubes		DN <sub>1</sub>	D <sub>k</sub>	H/2	h	A <sub>0</sub>		I <sub>1</sub> At number of passes through tubes	I <sub>2</sub>			I <sub>k</sub>			Partition wall location	
				2; 4	4			2; 4	4					KhNG KhKG	KhNV KhKV		KhKG	KhKV	I <sub>3</sub>	Number				
																					400	1500	400	1500
1000	2.5	3000	4230	1500	2300	300	8300	200	300	-	779	712	380	785	2; 4	400	1500	-	-	520	4			
		4000	5230	2000	3300											600	1800				6			
		6000	7230	3000	5300											1200	1800				10			
		9000	10230	6000	8300											1200	1800				16			
1200	4.0	3000	4280	1500	2250	350	8200	250	350	-	716	810	2; 4	400	1500	-	-	550	4					
		4000	5280	2000	3250									600	1800				6					
		6000	7280	3000	5250									1200	1800				10					
		4000	5330	2000	3200									700	1200				6					
1200	1.6	6000	7330	3000	5200	350	8200	250	350	1362	831	812	450	835	2; 4	1200	1800	1000	-	550	8			
		9000	10330	6000	8200											1200	1200				14			
		4000	5340	2000	3200											700	1200				6			
		6000	7340	3000	5200											1200	1800				8			
1200	2.5	4000	5380	2000	3200	350	8200	250	350	-	822	822	450	835	2; 4	700	1200	-	-	550	6			
		6000	7380	3000	5200											1200	1200				8			
		9000	10380	6000	8200											1200	1200				14			
		4000	5380	2000	3200											700	1200				6			

1) Apply 4-passes through tubes coolers for units with shell diameter > 600 (630) mm.

2) Outer shell diameter (at tube manufacturing).

3) Coolers designed for operation at nominal pressure PN 0.6; 1.0 and 1.6 MPa, differ by flanges, which are mounted on nominal pressure PN 0.6; 1.0 and 1.6.

#### Notes:

- Apply coolers with shell diameter 159; 273; 325; 400 (426) mm on shell nominal pressure 1.6 MPa only for KhK units of M3 material version with brass heat transferring tubes.
- Apply heat exchangers as coolers with shell diameter of 159; 273; 325; 400 (426) mm on nominal shell pressure 1.6; 2.5; 4.0 MPa of M1, M10, M11, M12, M19, M20 material version with steel heat transferring tubes.

Multi-pass through tubes heat exchangers of KNG, KKG types

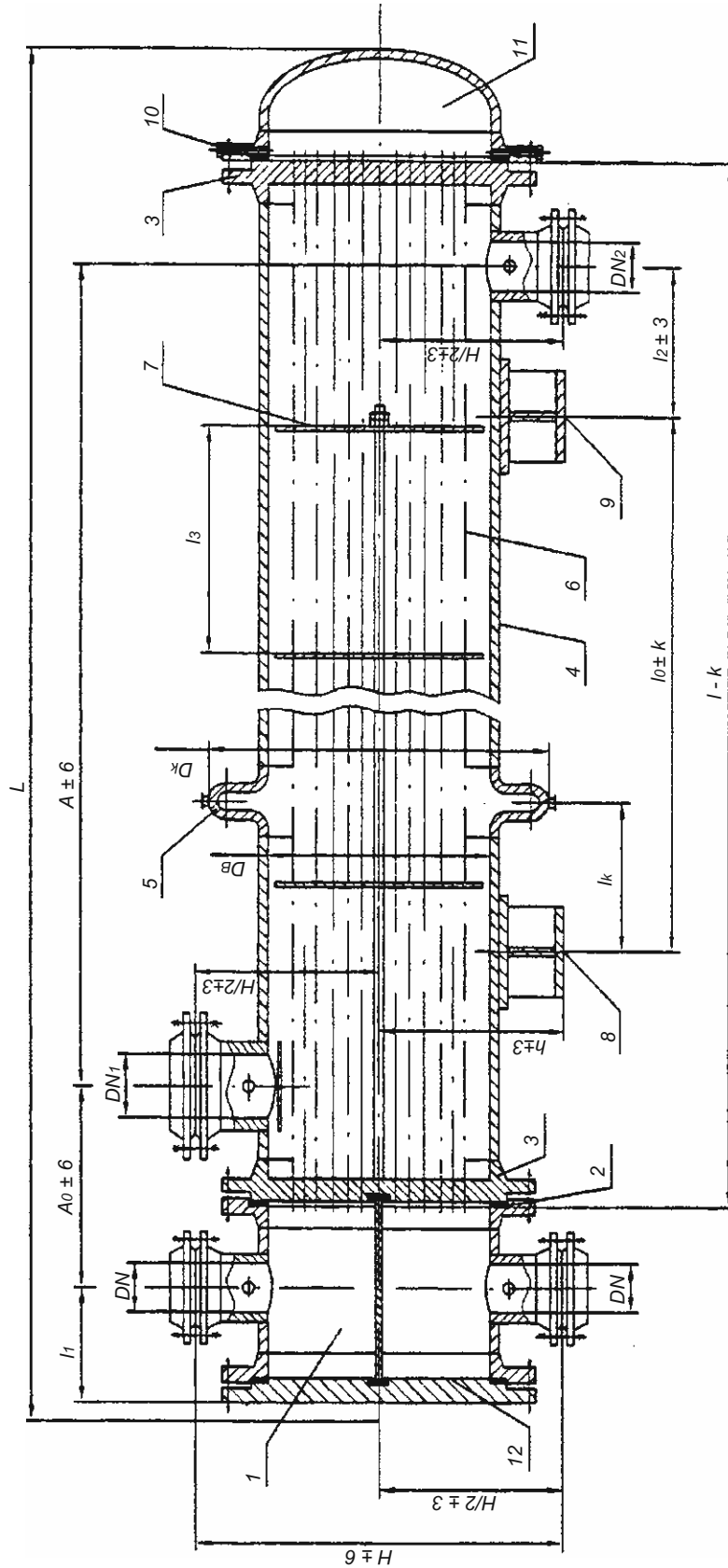

1 - distributing chamber; 2 - distributing chamber gasket; 3 - tube sheet; 4 - shell; 5 - expansion pipe; 6 - heat-transferring tube; 7 - partition wall; 8 - fixed support; 9 - removable support; 10 - shell gasket; 11 - shell cover; 12 - distributing chamber cover.

**Notes:**

1. The draw does not specify heat exchanger design.
2.  $k=5$  mm, if the length of tubes  $\leq 3000$  mm and  $k=10$ , if the length of tubes  $> 3000$  mm.
3. Dimensions  $l_1, L, l_k, D_k$  are recommended, specified at detailed documentation development.





Multi-pass through tubes heat exchangers of KNV, KKV types

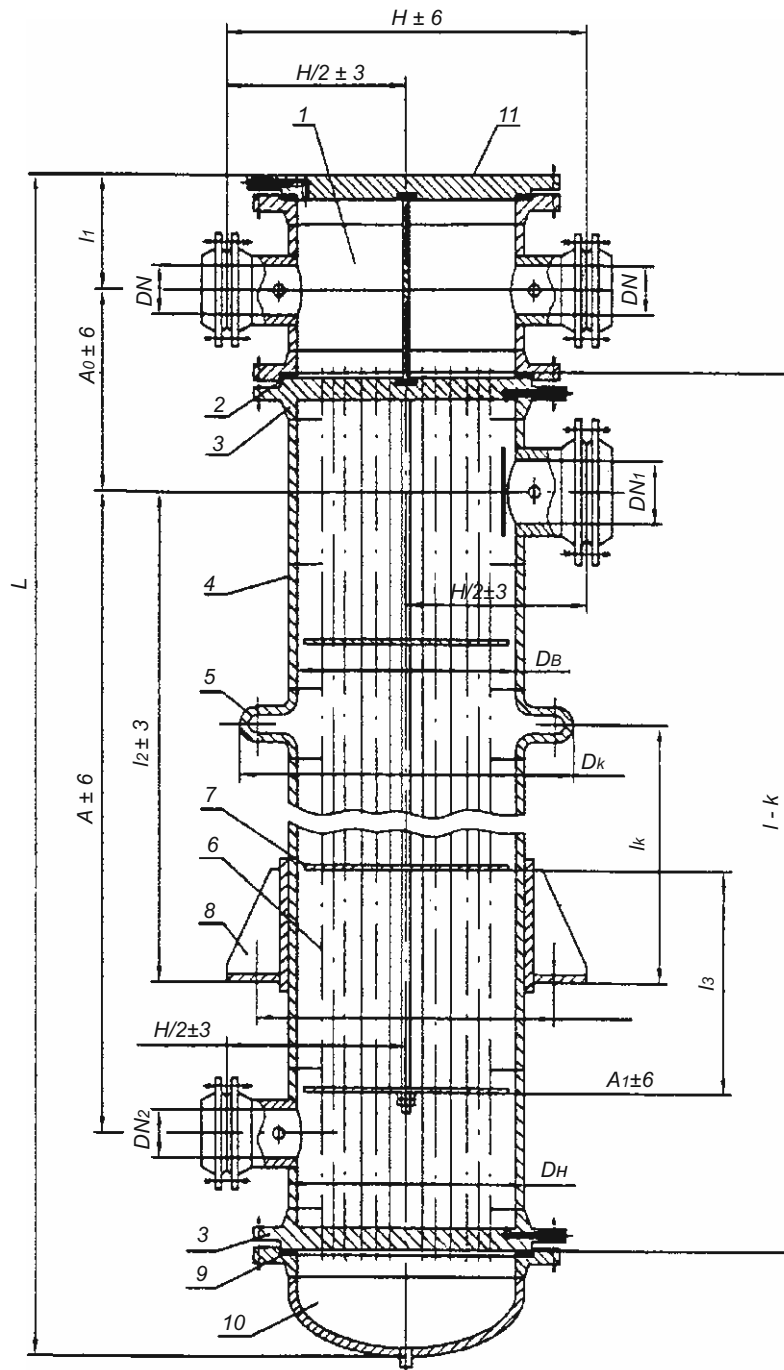

1 - distributing chamber; 2 - distributing chamber gasket; 3 - tube sheet; 4 - shell; 5 - expansion pipe; 6 - heat-transferring tube; 7 - partition wall; 8 - fixed support; 9 - removable support; 10 - shell cover; 11 - shell gasket; 12 - distributing chamber cover.

#### Notes:

1. The draw does not specify heat exchanger design.
2.  $k=5$  mm, if the length of tubes  $\leq 3000$  mm and  $k=10$ , if the length of tubes  $> 3000$  mm.
3. Dimensions  $l_1$ ,  $L$ ,  $l_k$ ,  $D_k$  are recommended, specified at detailed documentation development.



Basic parameters of KN and KK heat exchangers

Dimensions, mm																						
Shell ID	Pressure in shell PN, MPa	l	L, max.	l <sub>0</sub>	A	DN at number of passes through tubes			DN <sub>1</sub>	DN <sub>2</sub>	D <sub>k</sub>	H/2	h	A <sub>0</sub>	I <sub>1</sub>	I <sub>2</sub>		I <sub>k</sub>		Partition wall location		
						2	4	6								KNG KKG	KNV KKV	KNG	KKV	I <sub>3</sub>	Number	
600 630 <sup>1)</sup>	1.0	3000	3890	1500	2500	200	150	300	100	768	530	525	625	310	500	1500	750	900	1000	2		
		4000	4890	2000	3500										800	1800	1000	1000		3		
		6000	6890	3000	5500										1200	1800	1500	1000		5		
	1.6	3000	3890	1500	2540	200	150	250	100	-	962	627	608	640	315	500	1500	750	900	1000	2	
		4000	4890	2000	3540											800	1800	1000	1000		3	
		6000	6890	3000	5540											1200	1800	1500	1000		5	
800	1.0	3000	3900	1500	2550	200	150	200	-	962	627	608	710	315	500	1500	750	900	1000	2		
		4000	4900	2000	3550										800	1800	1000	1000		3		
		6000	6900	3000	5550										1200	1800	1500	1000		5		
	1.6	3000	3970	1500	2480	250	200	300	150	-	962	627	608	640	315	600	1500	750	900	1000	2	
		4000	4970	2000	3480											800	1800	1000	1000		3	
		6000	6970	3000	5480											1200	1800	1500	1000		5	
2.5	3000	3970	1500	2460	250	200	250	-	-	-	612	-	-	-	600	1500	-	-	-	2		
	4000	4970	2000	3460											800	1800	-	-		3		
	6000	6970	3000	5460											1200	1800	-	-		5		



Shell ID	Pressure in shell PN, MPa	I	L <sub>max.</sub>	I <sub>0</sub>	A	DN at number of passes through tubes			DN <sub>1</sub>	DN <sub>2</sub>	D <sub>k</sub>	H/2	h	A <sub>0</sub>	I <sub>1</sub>	I <sub>2</sub>		I <sub>k</sub>		Partition wall location				
						2	4	6								KNG KKG	KNV KKV	KNG	KKV	I <sub>3</sub>	Number			
																						Dimensions, mm		Continuation sheet
1000	0.6; 1.0 <sup>2)</sup>	3000	4200	1500	2400	300	200	150	400	1162	729	712	800	380	900	400	1500	-	1000	2	3	5		
		4000	5200	2000	3400											600	1800						1000	3
		6000	7200	3000	5400											1200	1800						1000	5
1000	1.6	3000	4200	1500	2430	300	200	150	300	1162	729	712	760	380	900	400	1500	-	1000	2	3	5		
		4000	5200	2000	3430											600	1800						1000	3
		6000	7200	3000	5430											1200	1800						1000	5
1000	2.5	3000	4210	1500	2400	300	200	150	250	-	779	780	780	-	-	400	1500	-	1000	2	3	5		
		4000	5210	2000	3400											600	1800						1000	3
		6000	7210	3000	5400											1200	1800						1000	5
1200	0.6; 1.0 <sup>2)</sup>	4000	5380	2000	3300	350	250	200	500	1362	831	860	860	450	1000	700	1800	-	1000	3	5	5		
		6000	7380	3000	5300											400	1800						1000	5
		4000	5380	2000	3300											350	1800						1000	3
1200	1.6	4000	5380	2000	3300	350	250	200	350	-	879	850	850	-	-	700	1800	-	1000	3	5	5		
		6000	7380	3000	5300											400	1800						1000	5
		4000	5400	2000	3250											350	1800						1000	3
1400	0.6; 1.0 <sup>2)</sup>	6000	7400	3000	5250	350	250	200	500	1562	990	908	990	575	1000	1200	1800	-	1000	5	5	5		
		6000	7630	3000	5200											400	1800						1000	5
		6000	7630	3000	5200											350	1800						1000	5
1400	1.6	6000	7630	3000	5200	350	250	200	500	1562	990	912	970	575	1000	1200	1800	-	1000	5	5	5		
		6000	7630	3000	5200											400	1800						1000	5
		6000	7630	3000	5200											350	1800						1000	5
1400	2.5	6000	7630	3000	5200	350	250	200	350	-	916	916	950	-	-	1200	1800	-	1000	5	5	5		
		6000	7630	3000	5200											400	1800						1000	5
		6000	7630	3000	5200											350	1800						1000	5

1) Shell outer diameter (when made of tube).

2) Condensers, designed for operation at nominal pressure PN 0.6 and 1.0 MPa, differ by flanges, which are mounted on nominal pressure PN 0.6 and 1.0 MPa.



## 83 IN-1, IK-1 Types Heat Exchangers

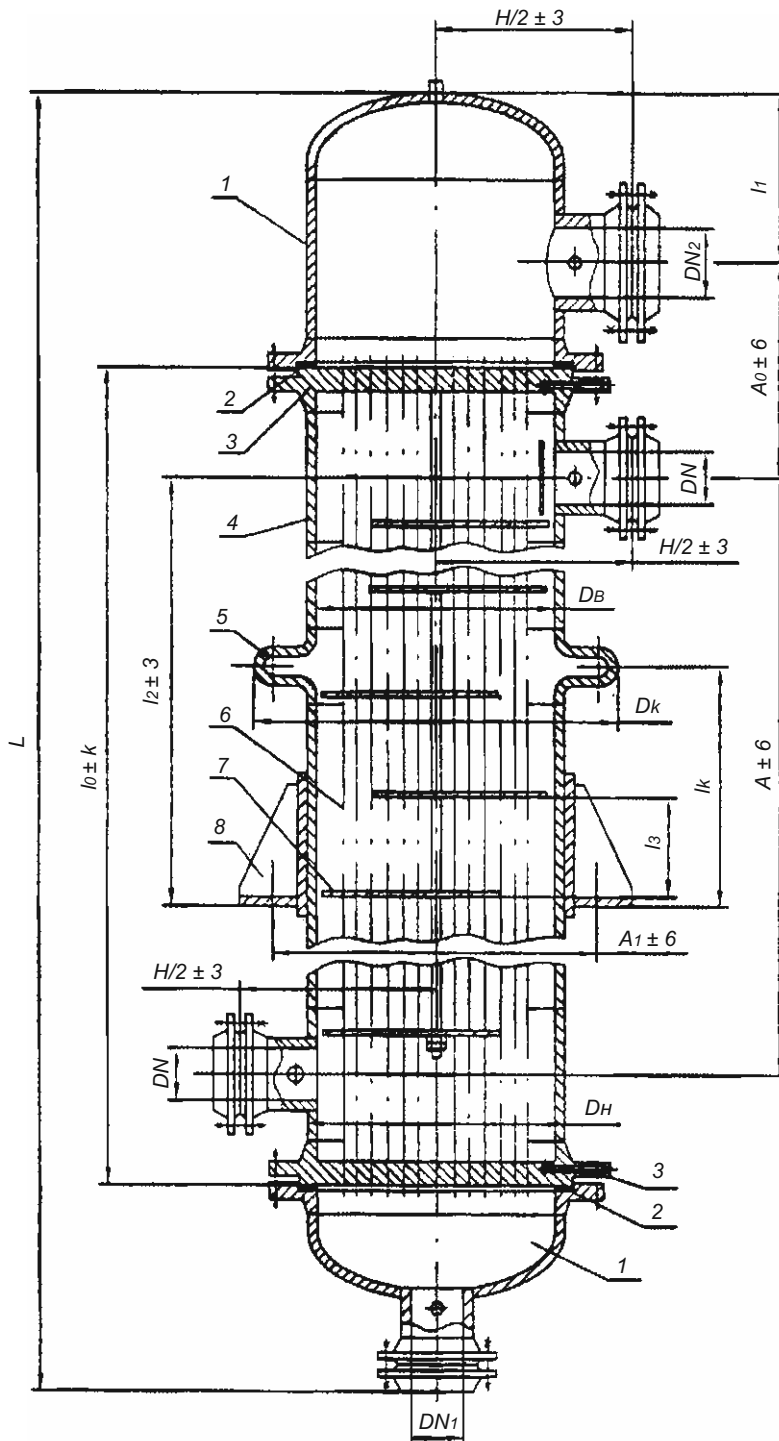

1- distributing chamber; 2 - distributing chamber gasket; 3 - tube sheet; 4 - shell; 5 - expansion pipe; 6 - heat-transferring tube; 7- partition wall; 8 - fixed support; 9 - removable support.

### Notes:

1. The draw does not specify heat exchanger design.
2.  $k=5$  mm, if the length of tubes  $\leq 3000$  mm and  $k=10$ , if the length of tubes  $> 3000$  mm.
3. Dimensions  $l_1$ ,  $L$ ,  $l_k$ ,  $D_k$  are recommended, specified at detailed documentation development.



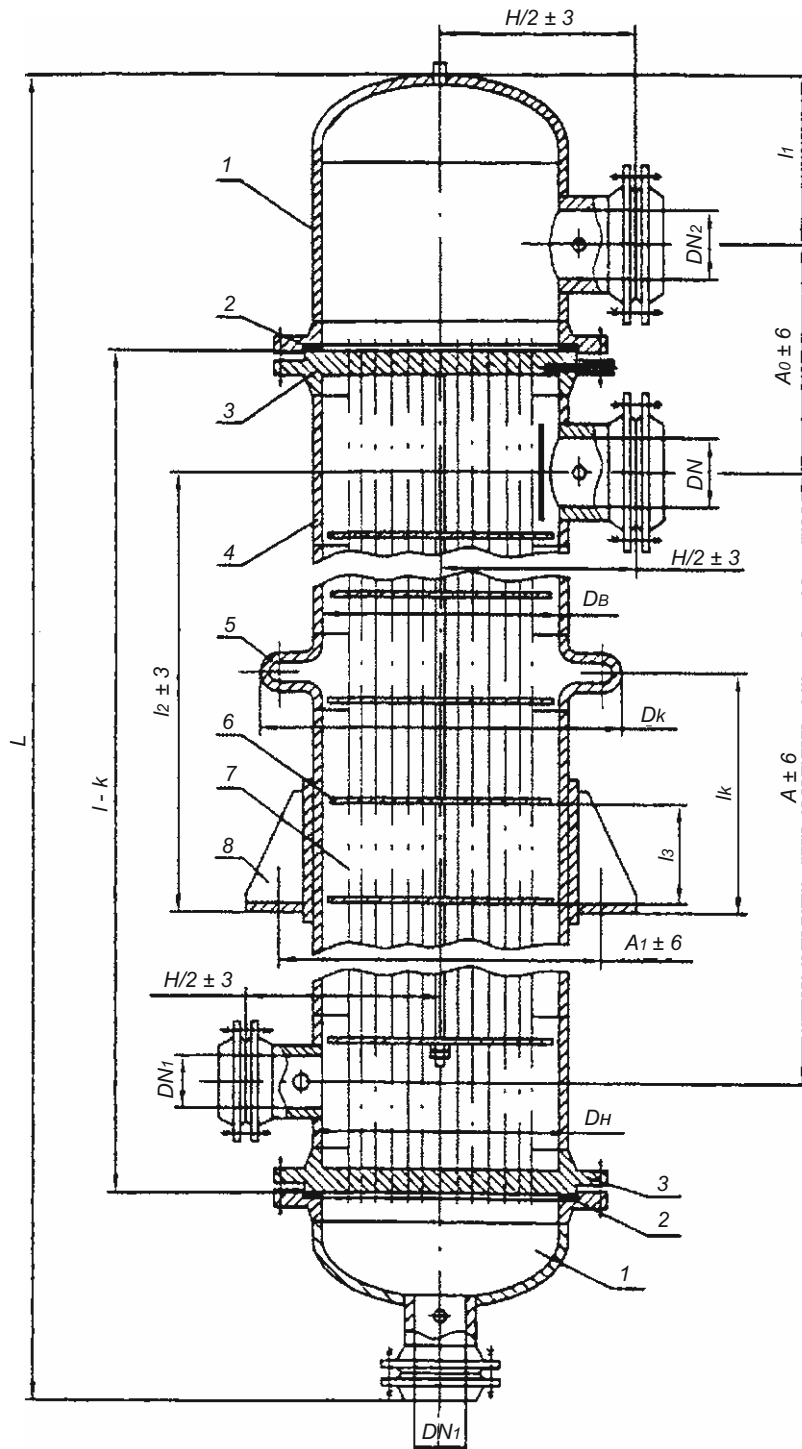

1- distributing chamber; 2 - distributing chamber gasket; 3 - tube sheet; 4 - shell; 5 - expansion pipe; 6 - heat-transferring tube; 7- partition wall; 8 - fixed support; 9 - removable support.

**Notes:**

1. The draw does not specify heat exchanger design.
2.  $k=5$  mm, if the length of tubes  $\leq 3000$  mm and  $k=10$ , if the length of tubes  $> 3000$  mm.
3. Dimensions  $h_1, L, l_k, D_k$  are recommended, specified at detailed documentation development.



Basic parameters of IN and IK heat exchangers

Dimensions, mm

Shell ID	Pressure in shell PN, MPa	l	L, max.	design						DN	DN1	DN2	D <sub>k</sub>	H/2	l <sub>1</sub>	l <sub>2</sub>	l <sub>k</sub>	Partition wall location for design					
				A		A <sub>0</sub>		2										1	3	Number	1	3	Number
				1	2	1	2	1	2														
600 630 <sup>1)</sup>	1.0	2000	1500	1500	540	595	300	200	300	100	300	762	400	1200	700	300	4	1000	2				
		3000	2500	2500													585		250	8	2		
		4000	3500	3500													585		200	10	3		
	2.5	2000	1500	1540	575	620	200	200	200	100	300	--	400	1200	700	300	4	1000	2				
		3000	2450	2520													595		200	8	2		
		4000	3450	3520													595		200	10	3		
	4.0	2000	1400	1490	605	620	200	200	200	100	300	--	400	1200	700	300	4	1000	2				
		3000	2400	2490													620		200	8	2		
		4000	3400	3490													620		200	10	3		
	800	1.0	2000	1450	1410	630	700	400	250	400	150	400	962	560	1200	700	350	4	1000	2			
			3000	2450	2410													710		300	6	2	
			4000	3450	3410													710		300	8	3	
2.5		2000	1410	1440	700	725	250	250	250	150	400	627	560	1200	700	350	4	1000	2				
		3000	2410	2440													710		300	6	2		
		4000	3410	3440													710		300	8	3		
4.0	2000	1400	1410	700	750	250	250	250	150	400	677	560	1200	700	350	4	1000	2					
	3000	2350	2390													750		250	6	2			
	4000	3350	3390													750		250	8	3			



Continuation sheet

Shell ID	Pressure in shell PN, MPa	l	L, max.	Dimensions, mm						Partition wall location for design												
				A		A <sub>0</sub>		DN		DN <sub>1</sub>	DN <sub>2</sub>	D <sub>k</sub>	H/2	I <sub>1</sub>	I <sub>2</sub>	I <sub>k</sub>	1		2			
				1	2	1	2	1	2								I <sub>3</sub>	Number	I <sub>3</sub>	Number		
1000	0.6; 1.0 <sup>2)</sup>	2000	3600	1350	1390	690	720	300	400	200	400	550	1300	800	520	2	1000	2	2			
		3000	4600	2350	2390								730	300		1500		900	4	2		
		4000	5600	3350	3390								740	300		1800		1000	6	3		
	1.6	2000	3600	1350	1390	730	730	300	400	200	400	550	1300	800	520	2	1000	2	2			
		3000	4600	2350	2390								740	300		1500		900	4	2		
		4000	5600	3350	3390								755	300		1800		1000	6	3		
1200	0.6; 1.0 <sup>2)</sup>	2000	3660	1250	1320	755	765	350	500	250	500	670	1300	--	550	2	1000	2	2			
		3000	4660	2250	2320								779	350		1500		900	4	2		
		4000	5660	3250	3320								830	350		1800		1000	6	3		
	1.6	2000	4880	2200	2290	830	850	350	400	250	500	670	1500	900	550	4	1000	4	2			
		3000	5880	3200	3290								860	400		1500		900	6	3		
		4000	6880	4200	4240								870	400		1800		1000	6	3		
2.5	2000	4950	2200	2240	835	870	350	350	250	500	670	1500	-	550	4	1000	4	2				
	3000	5950	3200	3240								880	350		1500		900	6	3			
	4000	6950	4200	4240								890	350		1800		1000	6	3			
1400	0.6; 1.0 <sup>2)</sup>	2000	5040	2250	2260	820	880	350	500	250	500	710	1500	900	600	4	1000	4	2			
		3000	6040	3250	3260								890	350					1500	900	6	3
		4000	7040	4250	4230								900	350					1800	1000	6	3
	1.6	2000	5040	2250	2230	830	890	350	400	250	500	710	1500	900	600	4	1000	4	2			
		3000	6040	3250	3230								900	350					1500	900	6	3
		4000	7040	4250	4210								900	350					1800	1000	6	3
2.5	2000	5050	2250	2210	830	900	350	350	250	500	710	1500	-	600	4	1000	4	2				
	3000	6050	3250	3210								900	350					1500	900	6	3	
	4000	7050	4250	3210								900	350					1800	1000	6	3	

1) Shell outer diameter (when made of tube).

2) Vaporizers, designed for operation at nominal pressure PN 0.6 and 1.0 MPa, differ by flanges, which are mounted on nominal pressure PN 0.6 and 1.0 MPa.



Heat exchange surface as to tubes outer diameter and clear opening area as to tube and shell side for TN, TK, KhN, KhK heat exchangers

Shell diameter		Dimensions, mm										Clear opening area as to shell side, m <sup>2</sup> , min		
		Heat exchange surface, m <sup>2</sup> , at tubes length						Clear opening area of one pass through tubes, m <sup>2</sup> , min.	In partition wall slot	Between partition walls <sup>1)</sup>				
Outer	Inner	Tube OD	Tube wall thickness	Number of passes through tubes	1000	1500	2000				3000	4000	6000	9000
159	-	20		1	1.2	1.8	2.4	3,6	-	-	-	0.0040	0.0019	0.0070
		25			1.0	1.5	2.0	3,1	-	-	-	0.0045	0.0033	0.0075
273	-	20		1	4.3	6.4	8.5	12,8	-	-	-	0.0136	0.0067	0.0124
		25			3.3	4.9	6.6	10,0	-	-	-	0.0147	0.0081	0.0137
325	-	20		1	-	9.4	12.5	18.8	25.0	-	-	0.0200	0.0110	0.0190
		25			-	8.5	11.3	16.9	22.6	-	-	0.0090	0.0130	0.0156
426	400	20		2	-	7.3	9.7	14.6	19.5	-	-	0.0217	0.0130	0.0278
		25			-	6.6	8.8	13.2	17.6	-	-	0.0098	0.0147	0.0147
426	400	20		2	-	-	22.5	33.7	45.0	67.4	-	0.0358	0.0180	0.0448
		25			-	-	20.9	31.3	41.7	62.6	-	0.0162	0.0300	0.0438
630	600	20		1	-	-	16.8	25.2	33.6	50.4	-	0.0375	0.0210	0.0540
		25			-	-	15.4	23.1	30.8	46.2	-	0.0168	0.0250	0.0480
630	600	20		2	-	-	50.4	75.5	100.7	151.1	-	0.0802	0.0426	0.0540
		25			-	-	47.7	71.6	95.5	143.2	-	0.0370	0.0480	0.0540
630	600	20		4	-	-	43.2	64.8	86.4	129.6	-	0.0162	0.0426	0.0480
		25			-	-	41.6	62.4	83.2	124.8	-	0.0928	0.0426	0.0480
630	600	20		2	-	-	38.9	58.4	77.9	116.8	-	0.0420	0.0400	0.0450
		25			-	-	33.6	50.4	67.2	100.8	-	0.0179	0.0400	0.0450





Shell diameter		Tube OD	Tube wall thickness	Number of passes through tubes	Heat exchange surface, m <sup>2</sup> , at tubes length						Clear opening area of one pass through tubes, m <sup>2</sup> , min.	Clear opening area as to shell side, m <sup>2</sup> , min				
					1000	1500	2000	3000	4000	6000		9000	In partition wall slot	Between partition walls <sup>1)</sup>		
-	Inner	20		1	-	94.1	141.1	188.1	282.2	-	0.1498	0.0693	0.0770			
					-	90.5	135.7	180.9	271.4	-	0.0706		0.0700			
					-	83.9	125.9	167.8	254.1	-	0.0308	0.0788				
					-	74.4	111.6	148.8	223.3	-	0.1659	0.0700				
-	Inner	25		2	-	70.8	106.2	141.6	212.4	-	0.0774	0.0662	0.0788			
					-	64.5	96.8	129.1	193.6	-	0.0329		0.0700			
					-	-	224.0	298.7	448.0	672.0	0.2378	0.1560				
					-	-	216.8	289.1	433.7	650.4	0.1138	0.1248				
-	Inner	20		4	-	-	205.0	273.3	410.0	615.0	0.0512	0.1048	0.1414			
					-	-	181.6	242.1	363.1	544.7	0.2695		0.1300			
					-	-	174.5	232.7	349.0	523.5	0.1257	0.1870				
					-	-	162.3	216.3	324.5	486.8	0.0553	0.1760				
-	Inner	25		1	-	-	-	432.3	648.5	972.7	0.3442	0.1495	0.1870			
					-	-	-	421.5	632.3	948.4	0.1658		0.1760			
					-	-	-	-	401.9	602.9	904.3	0.0788	0.1788			
					-	-	-	-	349.8	524.7	787.0	0.3899	0.1650			
-	Inner	20		2	-	-	-	338.8	508.2	762.3	0.1834	0.1640	0.1650			
					-	-	-	319.3	479.0	718.5	0.0854		0.1650			
					-	-	-	-	-	-	-	-	-	-	-	-
					-	-	-	-	-	-	-	-	-	-	-	-

1) Clear opening area is specified in the row 0 for one-pass through tubes heat exchangers and in row 1 for 2- and 4-pass heat exchangers.

Notes: 1. One-pass through tubes heat exchangers should be applied only for TN and TK heat exchangers with shell diameter 159 - 1200 mm and for KhK heat exchangers with shell diameter 159 and 273 mm.

2. Tube outer diameter 20 mm should be applied for TN and TK heat exchangers.



Heat exchange surface as to tubes outer diameter and clear opening area as to tube and shell side for KN and KK, heat exchangers

Shell diameter		Outer tube diameter	Tube wall thickness	Pressure in shell, PN MPa, max.	Number of passes through tubes	Heat exchange surface, m <sup>2</sup> , at tubes length			Clear opening area of one pass through tubes, m <sup>2</sup> , min.
						3000	4000	6000	
630	inner	600	2	1.0; 1.6	2	55.81	74.42	111.63	0.0377
						47.81	63.74	95.62	0.0142
						45.45	60.60	90.90	0.0087
630	inner	600	2	2.5	2	58.40	77.87	116.81	0.0415
						50.40	67.20	100.79	0.0180
						48.04	64.06	96.08	0.0107
—	inner	25	2	1.0	2	102.91	137.22	205.83	0.0716
						93.49	124.66	187.00	0.0328
						90.20	120.26	180.39	0.0180
—	inner	800	2	1.6; 2.5	2	106.21	141.61	212.42	0.0765
						96.79	129.05	193.58	0.0332
						93.49	124.66	186.99	0.0222
—	inner	1000	2	0.6; 1.0 1.6; 2.5	2	174.51	232.67	349.01	0.1242
						162.26	216.35	324.52	0.0557
						156.61	208.81	313.22	0.0363

Dimensions, mm



Continuation sheet

Dimensions, mm

Shell diameter		Outer tube diameter	Tube wall thickness	Pressure in shell, PN MPa, max.	Number of passes through tubes	Heat exchange surface, m <sup>2</sup> , at tubes length			Clear opening area of one pass through tubes, m <sup>2</sup> , min.
						3000	4000	6000	
-	inner	1200		0.6; 1.0	2	-	332.53	498.79	0.1744
					4	-	313.06	469.59	0.0790
					6	-	305.52	458.28	0.0453
-	inner	1200		1.6; 2.5	2	-	338.81	508.21	0.1814
					4	-	319.34	479.01	0.0861
					6	-	311.80	467.70	0.0523
-	inner	1400		0.6; 1.0	2	-	-	706.03	0.2527
					4	-	-	671.18	0.1111
					6	-	-	657.00	0.0727
-	inner	1400		1.6; 2.5	2	-	-	716.39	0.2603
					4	-	-	681.54	0.1187
					6	-	-	667.41	0.0803



Heat exchange surface as to tubes outer diameter and clear opening area as to tube and shell side for IN and IK heat exchangers

Dimensions, mm											
Heat exchanger designation	Shell diameter		Outer tube diameter	Tube wall thickness	Pressure in shell, PN MPa, max.	Heat exchange surface, m <sup>2</sup> , at tubes length			Clear opening area of one pass through tubes, m <sup>2</sup> , min.	Clear opening area as to shell side, m <sup>2</sup> , min	
	outer	inner				2000	3000	4000		In partition wall slot	Between partition walls
IN - 1 IK - 1	630	600			1.0; 1.6; 2.5; 4.0	41.61	62.41	83.21	0.0917	0.0397	0.0525
						39.88	59.82	79.76			
IN - 2 IK - 2					2.5; 4.0	41.60	62.41	83.21	0.0917	-	-
						74.42	111.63	148.84			
IN - 1 IK - 1			25		1.0	72.22	108.33	144.44	0.1592	-	-
						74.42	111.63	148.84			
IN - 1 IK - 1					0.6; 1.0 1.6; 2.5; 4.0	120.89	181.34	241.78	0.2665	0.1065	0.1430
						-	-	-			
IN - 2 IK - 2					4.0	-	-	-	-	-	-
						-	-	-			



Heat exchanger designation	Shell diameter		Outer tube diameter	Tube wall thickness	Pressure in shell, PN MPa, max.	Heat exchange surface, m <sup>2</sup> , at tubes length			Clear opening area of one pass through tubes, m <sup>2</sup> , min.	Clear opening area as to shell side, m <sup>2</sup> , min	
	outer	inner				2000	3000	4000		In partition wall slot	Between partition walls
IN - 1 IK - 1					0.6; 1.0;	174.89	262.35	349.80	0.3856	0.1640	0.1788
IN - 2 IK - 2	–	1200			0.6; 1.0;	171.76	257.64	343.52	0.378	–	–
IN - 1 IK - 1			25	2	1.6; 2.5	174.89	262.35	349.80	0.3856	–	–
IN - 1 IK - 1					0.6; 1.0; 1.6; 2.5	245.23	367.85	490.47	0.5406	0.1355	0.2250
IN - 2 IK - 2	–	1400			0.6; 1.0	241.78	362.67	483.56	0.5330	–	–
IN - 2 IK - 2					1.6; 2.5	245.23	367.85	490.47	0.5406	–	–

1) Clear opening area between partition walls is specified in the row 0

Notes:

- Heat exchange surface is given without thickness of tube sheets.
- TK KhK, KK, IK heat exchangers to be used to the pressure PN ≤ 1.6 MPa.



## Heat exchange surface as to tubes outer diameter and clear opening area as to tube and shell side for TN, TK, KhN and KhK heat exchangers

Materials for heat exchangers assembly units manufacturing					
Heat exchanger type	Heat exchanger material design	shell	distributing chamber	tubes	tube sheet
KhK KK	M3	Steel of grades 10 and 20 as to GOST 8731 (group B)***	Steel of grades 10 and 20 as to GOST 8731 (group B)***	Brass ЛАМш 77-2-0,05 as to GOST 21646	Steel 16ГC as to GOST 5520 GOST 8479 (group IV with ЛО-62-1 or Л163 brass facing as to GOST 15527)
	M1	Steel Cr3cn5 as to GOST 14637 Steel 09Г2 as to GOST 5520	Steel Cr3cn5 as to GOST 14637 Steel 09Г2 as to GOST 5520	Steel of grades 10 and 20 as to GOST 8733 (gr. B) and GOST 550 (gr. A) or electric welded tubes as to Technical Documents approved in accordance with established procedure	Steel of grade 20 as to GOST 1050 and GOST 8479 (gr IV)*** Steel 16ГC as to GOST 5520 GOST 8479 (group IV)
TN, TK, KhN, KhK, KN, KK, IN, IK	M8	Steel 12X18H10T as to GOST 9940*** Steel 12X18H10T as to GOST 5632 and GOST 7350	Steel 12X18H10T as to GOST 9940*** Steel 12X18H10T as to GOST 5632 and GOST 7350	Steel 08X18H10T, 12X18H10T as to GOST 9941 or electric welded tubes as to Technical Documents approved in accordance with established procedure	Steel 12X18H10T as to GOST 5632 and GOST 7350 (goup M26) GOST 25054 (group IV) and Technical Documents approved in accordance with established procedure
	M9	Steel 10X17H13M2T as to GOST 9940*** Steel 10X17H13M2T as to GOST 5632 and GOST 7350 (goup M26)	Steel 10X17H13M2T as to GOST 9940*** Steel 10X17H13M2T as to GOST 5632 and GOST 7350 (goup M26)	Steel 10X17H13M2T as to GOST 9941	Steel 10X17H13M2T as to GOST 5632 and GOST 7350 (goup M26) GOST 25054 (group IV) and Technical Documents approved in accordance with established procedure
TN, TK, KhN, KhK, KN, KK, IN, IK	M10	Steel 12X18H10T as to GOST 9940 *** Steel 10X17H13M2T as to GOST 5632 and GOST 7350 (goup M26)	Steel of grades 10 and 20 as to GOST 8731 (group B)*** Steel BCТ 3cn5 as to GOST 380 ***	Steel 08X18H10T, 12X18H10T as to GOST 9941 or electric welded tubes as to Technical Documents approved in accordance with established procedure	Steel 08X22H6T as to GOST 5632 and GOST 7350 (goup M26) GOST 25054 (group IV) and Technical Documents approved in accordance with established procedure
	M11	Steel 10X17H13M2T as to GOST 9940*** Steel 10X17H13M2T as to GOST 5632 and GOST 7350 (goup M26)	Steel Cr3cn5 as to GOST 14637 Steel 09Г2 as to GOST 5520	Steel 08X18H10T as to GOST 9941	Steel 10X17H13M2T as to GOST 5632 and GOST 7350 (goup M26) GOST 25054 (group IV) and Technical Documents approved in accordance with established procedure



## Heat exchange surface as to tubes outer diameter and clear opening area as to tube and shell side for TN, TK, KhN and KhK heat exchangers

Continuation sheet

		Materials for heat exchangers assembly units manufacturing				
Heat exchanger type	Heat exchanger material design	shell	distributing chamber	tubes	tube sheet	
TN, TK, KhN, KhK, KN, KK	M12	Steel Ct3cn as to GOST 380, GOST 14637 Steel 09Г2C as to GOST 5520 Tubes - steel grade 20 as to GOST 1050, GOST 8731 (group B)	Steel Ct3cn, Ct3cn <sup>1)</sup> as to GOST 380, 14637 <sup>2)</sup> Steel 09Г2C as to GOST 5520 Tubes - steel grade 20 as to GOST 1050, GOST 8731 (group B)	Steel 08X22H6T, 12x18H10T <sup>3)</sup> as to GOST 5632, GOST 9941	Steel 16ГC as to GOST 5520, GOST 8479	
TN, TK, IN, IK	M17	Steel 09Г2C as to GOST 5520 Tubes - steel 10Г2 as to GOST 8731 (gr. B) and 09Г2C as to Technical Documents approved in accordance with established procedure	Steel 09Г2C as to GOST 5520	Steel 10Г2 as to GOST 550 (group A), GOST 8733 <sup>3)</sup> (group B)	Steel 09Г2C and 10Г2C1 as to GOST 5520, 09Г2C and 10Г2 as to GOST479 (group IV)	
TN, TK, KhN, KhK, KN, KK	M19	Steel 08X22H6T as to GOST 5632 and GOST 7350 (goup M26)	Steel Ct3cn as to GOST 14637 Steel 09Г2C** as to GOST 5520	Steel 08X18H10T, 12X18H10T as to GOST 9941 or electric welded tubes as to Technical Documents approved in accordance with established procedure	Steel 08X22H6T as to GOST 5632, GOST 9941	
	M20	Steel 08X22H6T as to GOST 5632 and GOST 7350 (goup M26)		Steel 10X17H13M2T as to GOST 9941	Steel 08X21H6M2T as to GOST 5632 and Technical Documents approved in accordance with established procedure	
	M21	Steel 08X22H6T as to GOST 5632 and GOST 7350 (goup M26)		Steel 08X22H6T as to GOST 5632 and GOST 7350 (goup M26) GOST 25054 (group IV) and Technical Documents approved in accordance with established procedure	Steel 08X22H6T as to GOST 5632 and GOST 7350 (goup M26) GOST 25054 (group IV) and Technical Documents approved in accordance with established procedure	
TN, TK	M22	Steel 08X22H6T as to GOST 5632 and GOST 7350 (goup M26)		Steel 08X21H6M2T as to GOST 5632 and Technical Documents approved in accordance with established procedure	Steel 08X21H6M2T as to GOST 5632 and GOST 7350 (goup M26) GOST 25054 (group IV) and Technical Documents approved in accordance with established procedure	

\* To be applied for heat exchangers and vaporizers

\*\* To be applied only for heat exchangers

\*\*\* To be applied only for TN, TK, KhK heat exchangers of 159, 273, 325 mm diameter, for M9, M11 design of 59 mm diameter (KhK only for M3 design).

Notes: It is allowed to produce components and parts of another material grades which match mechanical properties and corrosion resistance of materials which are in the table.

## Weight of TN, TK heat exchangers

Shell diameter		Dimensions, mm										Estimated weight, kg
		Tubes 20 x 2 with length					Tube 25 x 2 with length					
outer	inner	1000	1500	2000	3000	4000	1000	1500	2000	3000	4000	4000
		Pressure in shell and tubes PN, MPa, max.										
		1 pass										
159	-	145	170	190	245	-	135	165	185	235	-	-
		175	200	220	275	-	170	190	210	255	-	-
		175	200	220	275	-	170	190	210	255	-	-
		1 pass										
273	-	295	365	345	575	-	275	345	410	535	-	-
		355	425	495	630	-	345	415	475	600	-	-
		430	540	575	710	-	405	470	535	670	-	-
		1 pass										
		2 passes										
325	-	-	465	530	665	800	-	435	495	610	720	720
		-	540	605	740	900	-	510	570	690	820	820
		-	650	720	880	990	-	565	680	800	910	910
		2 passes										
1.6	-	440	500	620	745	-	415	465	575	680	680	680
2.5	-	510	570	700	820	-	480	535	645	750	750	750
4.0	-	605	660	810	950	-	575	625	730	900	900	900





Continuation sheet

Dimensions, mm

Shell diameter		Pressure in shell and tubes PN, MPa, max.	Tube 20 x 2 with length						Tube 25 x 2 with length						
			2000	3000	4000	6000	9000	2000	3000	4000	6000	9000			
outer	inner	Estimated weight, kg													
426		1.6	1 pass												
			860	1130	1430	1850	-	780	1030	1290	1750	-			
			980	1230	1540	1960	-	870	1140	1400	1860	-			
		4.0	1090	1290	1780	2120	-	1030	1200	1480	1940	-			
			1 pass												
			860	1130	1360	1930	-	790	1020	1340	1660	-			
		2.5	1020	1250	1490	2020	-	960	1180	1380	1860	-			
			4.0	1150	1470	1660	2240	-	1080	1350	1510	2130	-		
				1 pass											
1.6	1570	2030		2540	3540	-	1360	1840	2450	3190	-				
	2.5	1710	2250	2760	3840	-	1550	2020	2560	3480	-				
		4.0	2100	2670	3530	4380	-	1970	2470	3390	3950	-			
2 passes															
1.6	1520		1920	2350	3470	-	1350	1820	2190	2910	-				
	2.5	1870	2400	2920	3980	-	1710	2190	2640	3550	-				
		4.0	2430	3000	3560	4690	-	2290	2800	3280	4270	-			
4 passes															
1.6	1530		1880	2280	3320	-	1360	1780	2130	2760	-				
	2.5	1880	2360	2850	3830	-	1720	2150	2580	3400	-				
		4.0	2440	2960	3490	4540	-	2300	2760	3220	4120	-			
630			600	4 passes											
				1530	1880	2280	3320	-	1360	1780	2130	2760	-		
		1880		2360	2850	3830	-	1720	2150	2580	3400	-			
4.0	2440	2960	3490	4540	-	2300	2760	3220	4120	-					



Continuation sheet

Dimensions, mm

Shell ID	Pressure in shell and tubes PN, MPa, max.	Tube 20 x 2 with length						Tube 25 x 2 with length					
		2000	3000	4000	6000	9000	2000	3000	4000	6000	9000		
		Estimated weight, kg											
		<b>1 pass</b>											
	1.0	2640	3570	4310	6040	-	2300	3160	3760	5420	-	-	-
	1.6	2780	3640	4560	6340	-	2320	3280	4040	5460	-	-	-
	2.5	3190	4150	5110	7040	-	2920	3730	4570	6350	-	-	-
	4.0	3930	4970	6020	8110	-	3660	4600	5470	7070	-	-	-
		<b>2 passes</b>											
800	1.0	2680	3510	4350	6040	-	2520	3240	3960	5380	-	-	-
	1.6	2880	3760	4650	6340	-	2720	3450	4180	5620	-	-	-
	2.5	3180	4160	5100	7000	-	2870	3680	4500	6120	-	-	-
	4.0	4160	5110	6070	8010	-	4080	4740	5690	7340	-	-	-
		<b>4 passes</b>											
	1.0	2740	3510	4320	5920	-	2560	3260	3930	5260	-	-	-
	1.6	2940	3790	4620	6190	-	2790	3470	4150	5500	-	-	-
	2.5	3240	4160	5070	6880	-	2940	3700	4470	6000	-	-	-
	4.0	4220	5140	6040	7890	-	4150	4760	5660	7220	-	-	-
		<b>1 pass</b>											
	0.6	-	5020	6490	9000	12980	-	4410	5460	7870	11250	-	-
	1.0	-	5220	6560	9210	13180	-	4540	5770	7970	11400	-	-
	1.6	-	5600	6790	9870	13750	-	4890	6160	8370	12050	-	-
	2.5	-	6100	7570	10530	15180	-	5510	6790	9270	13350	-	-
	4.0	-	7110	8940	12180	-	-	6780	8190	11010	-	-	-
		<b>2 passes</b>											
1000	0.6	-	5050	6290	8770	12920	-	4480	5590	7810	11150	-	-
	1.0	-	5230	6540	9180	13120	-	4580	5710	7970	11350	-	-
	1.6	-	5520	6900	9660	13690	-	4930	6110	8370	11950	-	-
	2.5	-	6170	7580	10390	15120	-	5430	6800	9120	13200	-	-
	4.0	-	7710	9270	12380	-	-	7750	8950	11650	-	-	-



Continuation sheet

Dimensions, mm

Shell ID	Pressure in shell and tubes PN, MPa, max.	Tube 20 x 2 with length						Tube 25 x 2 with length					
		2000	3000	4000	6000	9000	2000	3000	4000	6000	9000		
Estimated weight, kg													
<b>4 pass</b>													
1000	0.6	-	5070	6250	8640	12610	-	4250	5570	7670	10830		
	1.0	-	5250	6500	9050	12810	-	4620	5690	7830	11030		
	1.6	-	5540	6860	9530	13380	-	4970	6090	8230	11630		
	2.5	-	6390	7540	10260	14810	-	5470	6780	8980	12880		
	4.0	-	7910	9490	12600	-	-	7450	8780	11440	-		
<b>1 pass</b>													
1000	0.6	-	-	8930	12760	18650	-	-	7910	11190	16080		
	1.0	-	-	9180	12910	18970	-	-	8210	11360	16280		
	1.6	-	-	9310	13100	19360	-	-	8460	11780	16730		
	2.5	-	-	11030	15220	21890	-	-	9910	13590	19810		
<b>2 passes</b>													
1200	0.6	-	-	9030	12750	18560	-	-	8000	11120	15850		
	1.0	-	-	9650	13360	19170	-	-	8350	11500	16250		
	1.6	-	-	9680	13740	19310	-	-	8600	11770	16600		
	2.5	-	-	11450	14800	21860	-	-	10100	13670	19100		
<b>4 passes</b>													
1200	0.6	-	-	9090	12660	18280	-	-	8040	11020	15530		
	1.0	-	-	9710	13290	18890	-	-	8390	11400	15930		
	1.6	-	-	9740	13390	19030	-	-	8640	11670	16280		
	2.5	-	-	11510	14720	21580	-	-	10140	13570	18780		



## Weight of KhK, KhN heat exchangers

Shell diameter		Pressure in shell and tubes PN, MPa, max.	Dimensions, mm																
			Tubes 25 x 2 with length						Estimated weight, kg										
outer	inner		1500	2000	3000	4000	6000	9000	steel	brass	steel	brass	steel	brass	steel	brass			
159 <sup>1)</sup>			1 pass																
			-	-	-	220	-	280	-	-	-	-	-	-	-	-	-	-	
			1 pass																
			-	-	380	-	450	-	580	-	-	-	-	-	-	-	-	-	-
273 <sup>1)</sup>		1.6	2 passes																
			-	-	470	-	530	-	670	-	-	-	-	-	-	-	-	-	
			2 passes																
			-	-	-	860	-	1080	-	1340	-	1780	-	-	-	-	-	-	-
325 <sup>1)</sup>			2 passes																
			-	-	1490	1550	1910	1990	2310	2420	3170	3350	-	-	-	-	-	-	
			-	-	1580	1640	2030	2110	2440	2550	3300	3420	-	-	-	-	-	-	-
			-	-	1610	-	2170	-	2680	-	3540	-	-	-	-	-	-	-	-
426 <sup>1)</sup>	400		2 passes																
			-	-	1960	-	2520	-	2930	-	3900	-	-	-	-	-	-	-	
			4 passes																
			-	-	1480	1540	1870	1930	2230	2320	3010	3170	-	-	-	-	-	-	-
630	600		-	-	1570	1630	1990	2050	2360	2450	3140	3240	-	-	-	-	-	-	
			-	-	1600	-	2130	-	2600	-	3380	-	-	-	-	-	-	-	-
			-	-	1950	-	2480	-	2850	-	3740	-	-	-	-	-	-	-	-
			-	-	-	-	-	-	-	-	-	-	-	-	-	-	-	-	-



Shell diameter		Dimensions, mm												Continuation sheet					
		Tubes 25 x 2 with length																	
		1500		2000		3000		4000		6000		9000							
outer	inner	Estimated weight, kg																	
		2 passes																	
-	800	Pressure in shell and tubes PN, MPa, max.	1.0	1.6	2.5	4.0	steel	brass	steel	brass	steel	brass	steel	brass	steel	brass	steel	brass	
			-	-	-	-	2540	2580	3270	3480	4000	4130	5430	5530	-	-	-	-	-
			-	-	-	-	2720	2820	3520	3590	4200	4290	5890	5980	-	-	-	-	-
			-	-	-	-	3000	-	3640	-	4450	-	-	-	-	-	-	-	-
			-	-	-	-	3420	-	4240	-	5100	-	-	-	-	-	-	-	-
4 passes																			
-	800	Pressure in shell and tubes PN, MPa, max.	1.0	1.6	2.5	4.0	steel	brass	steel	brass	steel	brass	steel	brass	steel	brass	steel	brass	
			-	-	-	-	2620	2630	3310	3500	3990	4100	5330	5400	-	-	-	-	
			-	-	-	-	2800	2890	3560	3610	4190	4260	5790	5850	-	-	-	-	
			-	-	-	-	3080	-	3680	-	4440	-	6060	-	-	-	-	-	
			-	-	-	-	3500	-	4280	-	5090	-	6620	-	-	-	-	-	
2 passes																			
-	1000	Pressure in shell and tubes PN, MPa, max.	0.6	1.0	1.6	2.5	4.0	steel	brass	steel	brass	steel	brass	steel	brass	steel	brass	steel	
			-	-	-	-	-	4630	5040	5760	6210	8020	8560	11400	12100	-	-	-	
			-	-	-	-	-	4780	5140	5910	6330	8120	8720	11500	12300	-	-	-	
			-	-	-	-	-	4970	5310	6140	6590	8370	9060	11900	12800	-	-	-	
			-	-	-	-	-	5280	-	6490	-	8870	-	12500	-	-	-	-	
	-	-	-	-	-	5780	-	7060	-	9650	-	-	-	-	-	-			



Dimensions, mm

Continuation sheet

Shell diameter	Pressure in shell and tubes PN, MPa, max.	Tubes 25 x 2 with length											
		1500		2000		3000		4000		6000		9000	
		steel	brass	steel	brass	steel	brass	steel	brass	steel	brass	steel	brass
<b>4 passes</b>													
-	0.6	-	-	-	-	4650	5050	5730	6210	7870	8370	11070	11720
	1.0	-	-	-	-	4880	5150	5880	6330	7970	8530	11170	11920
	1.6	-	-	-	-	4990	5320	6110	6390	8220	8870	11570	12220
	2.5	-	-	-	-	5300	-	6460	-	8720	-	12170	-
	4.0	-	-	-	-	5800	-	7030	-	9500	-	-	-
<b>2 passes</b>													
-	0.6	-	-	-	-	-	-	8400	9130	11610	12430	16500	17400
	1.0	-	-	-	-	-	-	8500	9300	11710	12680	16600	17750
	1.6	-	-	-	-	-	-	9000	9640	122100	13040	17100	18150
	2.5	-	-	-	-	-	-	9800	-	13170	-	18300	-
<b>4 passes</b>													
-	0.6	-	-	-	-	-	-	8430	9130	11500	12280	16180	17020
	1.0	-	-	-	-	-	-	8530	9300	11600	12530	16280	17370
	1.6	-	-	-	-	-	-	9030	9670	12100	12890	16780	17770
	2.5	-	-	-	-	-	-	9830	-	13060	-	17980	-

1) TN and TK heat exchangers should be applied as KhN and KhK heat exchangers with 159, 273, 325, 400 (426) mm shell diameter and with steel heat transferring tubes.



## Weight of KN, KK heat exchangers

Shell ID		Dimensions, mm					
		Tubes 25 x 2 with length					
		3000		4000		6000	
Pressure in shell and tubes PN, MPa, max.	Estimated weight, kg						
	steel	brass	steel	brass	steel	brass	
600 630 <sup>1)</sup>	<b>2 passes</b>						
	1.0	1760	1800	2200	2200	2900	3000
	1.6	1840	1900	2240	2310	3040	3130
	2.5	2030	-	2440	-	3270	-
	<b>4 passes</b>						
	1.0	1720	1740	2120	2100	2730	2810
	1.6	1800	1850	2160	2210	2880	2950
	2.5	1970	-	2360	-	3110	-
	<b>6 passes</b>						
1.0	1760	1780	2140	2120	2730	2810	
1.6	1840	1890	2190	2230	2840	2950	
2.5	2010	-	2390	-	3110	-	
<b>2 passes</b>							
1.0	3200	3220	3900	3920	5170	5320	
1.6	3490	3640	4100	4220	5670	5720	
2.5	3660	-	4460	-	5930	-	
<b>4 passes</b>							
1.0	3180	3820	3820	3830	5010	5130	
1.6	3420	3620	4030	4130	5510	5540	
2.5	3640	-	4390	-	5570	-	
<b>6 passes</b>							
1.0	3250	3250	3880	3880	5040	5150	
1.6	3490	3690	4090	4180	5540	5560	
2.5	3710	-	4450	-	5450	-	



Shell ID	Dimensions, mm						Continuation sheet					
	Tubes 25 x 2 with length											
	3000		4000		6000		3000		4000		6000	
Pressure in shell and tubes PN, MPa, max.	steel	brass	steel	brass	steel	brass	Estimated weight, kg					
	steel	brass	steel	brass	steel	brass	2 passes		4 passes		6 passes	
1000	0.6	4600	4760	5700	5900	7890	8200					
	1.0	4750	4820	5830	5980	7950	8310					
	1.6	5080	5270	6240	6460	8570	8850					
	2.5	5380	-	6570	-	8920	-					
	0.6	4610	4750	5560	5830	7720	8000					
	1.0	4760	4810	5790	5910	7780	8110					
	1.6	5090	5260	6200	6390	8400	8650					
	2.5	5390	-	6530	-	8750	-					
	0.6	4720	4850	5700	5900	7750	8010					
	1.0	4870	4910	5850	5980	7810	8120					
	1.6	5200	5360	6260	6460	8430	8660					
	2.5	5500	-	6680	-	8770	-					
1200	0.6	-	-	8200	8980	10950	12070					
	1.0	-	-	8500	9270	11380	12150					
	1.6	-	-	8930	9800	11770	12720					
	2.5	-	-	10040	-	12870	-					





Continuation sheet

Dimensions, mm

Shell ID	Pressure in shell and tubes PN, MPa, max.	Tubes 25 x 2 with length						
		3000		4000		6000		
		steel	brass	steel	brass	steel	brass	
		Estimated weight, kg						
1200		<b>4 passes</b>						
	0.6	-	-	8240	-	8980	10850	11930
	1.0	-	-	8540	-	9270	11280	12010
	1.6	-	-	8970	-	9700	11520	12410
	2.5	-	-	10080	-	-	12620	-
			<b>6 passes</b>					
	0.6	-	-	8440	-	9170	11000	12060
	1.0	-	-	8740	-	9460	11430	12140
	1.6	-	-	9170	-	9890	11670	12540
	2.5	-	-	10280	-	-	12770	-
1400		<b>2 passes</b>						
	0.6	-	-	-	-	15940	16520	
	1.0	-	-	-	-	16260	16800	
	1.6	-	-	-	-	16830	17360	
	2.5	-	-	-	-	17630	-	
			<b>4 passes</b>					
	0.6	-	-	-	-	15870	16400	
	1.0	-	-	-	-	15760	16680	
	1.6	-	-	-	-	16760	17250	
	2.5	-	-	-	-	17560	-	
		<b>6 passes</b>						
0.6	-	-	-	-	16100	16610		
1.0	-	-	-	-	16420	16890		
1.6	-	-	-	-	16690	17450		



# 105 Weight of IN, IK Heat Exchangers

## Weight of IN, IK heat exchangers

Dimensions, mm

Shell ID	Pressure in shell and tubes PN, MPa, max.	Tubes 25 x 2 with length					
		2000		3000		4000	
		Estimated weight, for design, kg					
		1	2	1	2	1	2
600 630 <sup>1)</sup>	1.0	1350	1330	1780	1750	2210	2170
	1.6	1410		1810		2230	
	2.5	1520		1990		2570	
	4.0	1840		2340		2930	
800	1.0	2320	2290	3230	3190	3700	3650
	1.6	2420		3380		3880	
	2.5	2720		3530		4340	
	4.0	3170		4130		5100	
1000	0.6	3460	3420	4640	4590	5810	5740
	1.0	3610	3530	4770	4720	5920	5850
	1.6	3710		4840		5960	
	2.5	3860		5240		6410	
	4.0	4980		6090		7450	
1200	0.6	-		6560	6490	8100	8010
	1.0	-		6610	6540	8300	8210
	1.6	-		6860		8500	
	2.5	-		7410		9050	
1400	0.6	-		8500		10500	
	1.0	-		8630		10680	
	1.6	-		9340		11450	
	2.5	-		11200		13200	

<sup>1)</sup> Outer shell diameter (to be made of tubes).

### Notes:

- Heat exchangers weight is calculated for steel with density 7.85 g/cm<sup>3</sup>.
- Tolerance on weight values must not exceed +8%.
- Heat exchangers weight is calculated for nominal thickness of heat transferring tubes and sheet metal without weight of hanging device for distributing chambers and covers to them.



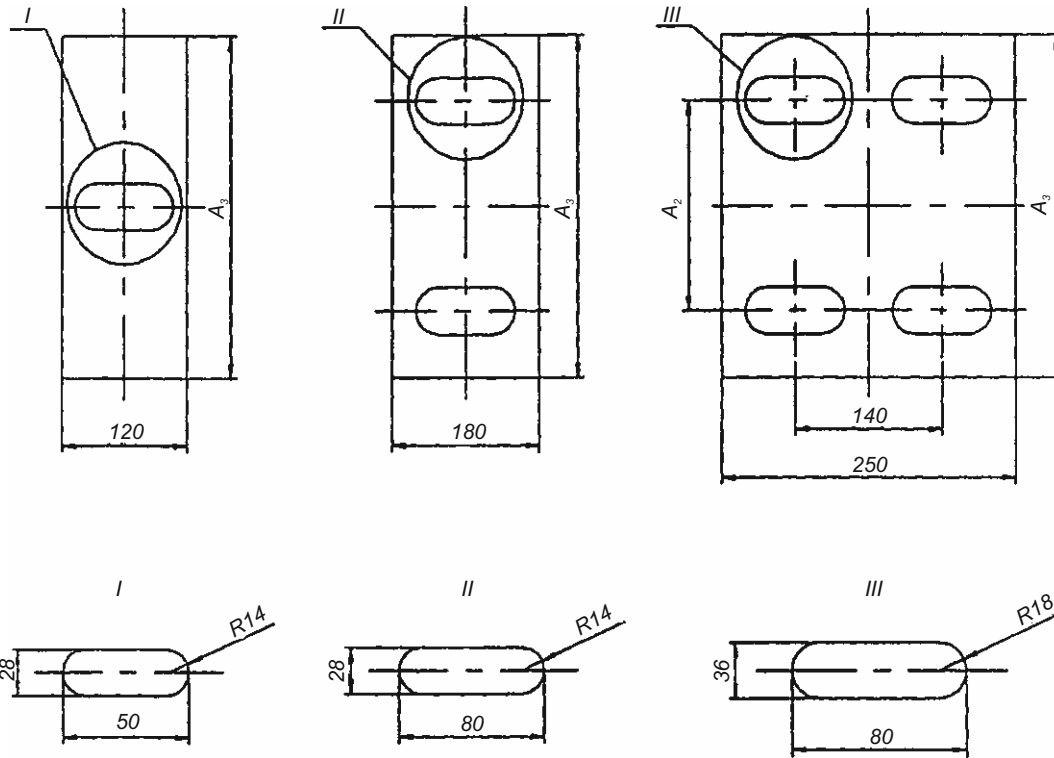

For supports of heat exchangers with diameter 800 mm slot in supporting plate to be 80x30 mm

Dimensions, mm

Shell diameter, mm		A <sub>2</sub>	A <sub>3</sub>
Outer	Inner		
159	-	-	180
273	-	-	290
325	-	330	400
426	400		450
630	600	450	600
-	800	500	740
-	1000	650	1000
-	1200	800	1100
-	1400	950	1250



# Layout of Supports and Nozzles in TN, TK, KhN, KhK, KN, KK, IN, IK Heat Exchangers

## Layout of supports and nozzles of TN, TK, KhN, KhK, KN, KK, IN, IK vertical heat exchangers

For TN, TK, KhN, KN, KK, IN, IK heat exchangers having 2 supports

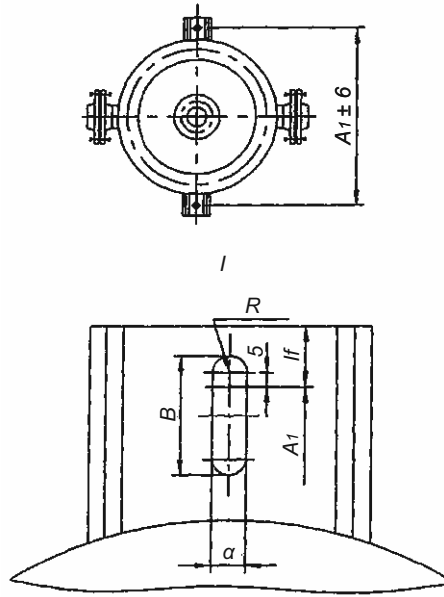

For TN, TK, KhN, KN, KK, IN, IK one pass through tubes heat exchangers having 4 supports

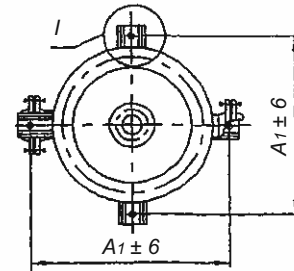

For TN, TK, KhN, KN, KK, IN, IK one pass through tubes heat exchangers having 4 supports

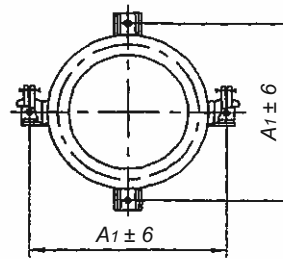

Dimensions, mm

Shell diameter		Pressure in shell, PN, MPa	Tube length, l	Quantity of supports	A <sub>1</sub>	R	B	If
Outer	Inner							
159	-	1.6; 2.5; 4.0	1000; 1500; 2000; 3000	2	322	12.0	24	40
273			40					
325	-	1.0; 1.6; 2.5; 4.0	1500; 2000; 3000; 4000	2	562	12.0	24	25
426	400	1.0; 1.6; 2.5; 4.0	2000; 3000		660			
630	600	1.0; 1.6; 2.5	4000; 6000	870	40	45		
-	800	1.0; 1.6; 2.5	3000	2 at l ≤ 2000			1126	17.5
			2000; 4000; 6000		1206	55		
-	1000	0.6; 1.0; 1.6; 2.5	3000	4 at l > 2000	1496		21.0	42
			2000; 4000; 6000; 9000			1294		
-	1200	0.6; 1.0; 1.6; 2.5	2000; 3000; 4000; 6000	4	1704	21.0	42	80
			3000; 4000; 6000					
-	1400	0.6; 1.0; 1.6; 2.5	9000	4	1910	21.0	42	80
			3000; 4000					
-	-	-	6000	-	-	-	-	70



## 108 Limit Working Pressure for Heat Exchangers

Nominal pressure PN, MPa	Limit working pressure MPa, at medium temperature, °C				
	up to 100	200	250*	300*	350*
0.6	0.6	0.56	0.54	0.48	0.40
1.0	1.0	0.93	0.90	0.75	0.66
1.6	1.6	1.49	1.40	1.20	1.10
2.5*	2.5	2.32	2.25	1.90	1.70
4.0*	4.0	3.72	3.50	3.00	2.60

\* Only for heat exchangers with steel tubes.

Notes: limit working pressure for heat exchangers should not exceed the limit working pressure of the materials specified in OST 26-291.



## ORDER FORM

for heat exchanger manufacturing as to Specifications TU 3612-024-00220302-02

## 1. Designation \_\_\_\_\_

2.	Design and operating conditions Medium parameter	in tubes	in shell
2.1.	Pressure, MPa		
	P working		
	P design		
2.2.	Working temperature, °C		
	inlet		
	outlet		
2.3.	Temperature of shell walls and tubes, °C		
2.4.	Design temperature, °C		
2.5.	Minimum allowed (negative) temperature of heat exchanger wall under pressure, °C		
2.6.	Average air temperature of the coldest five days at heat exchanger layout (site), °C, (fill for heat exchangers to be installed outdoors or in unheated rooms)		
2.7.	Temperature of working medium boiling at pressure 0.07 MPa, °C		
2.8.	Working medium designation and percentage composition		
2.9.	Physical state of medium (gas, vapor, liquid)		
2.10.	Medium characteristics: harmfulness as to standard GOST 12.1.007 (indicating the hazard class)		
	flammability as to standard GOST 12.1.004 "yes", "no"		
	explosive hazard as to standard GOST 12.1.011 (indicating mixture category and group)		
	Does medium cause stress corrosion cracking "yes", "no", if "yes" testing to be fulfilled		
3.	<b>Gasket material</b>		

4. Necessity of installation of parts for thermal insulation fixing  
"yes", "no" (delete as applicable)  
(parts are installed for heat exchangers with shell diameter  $\geq 500$  mm)

5. Necessity of ICC testing of base metal and welded joints  
"yes", "no", if "yes" specify procedure as to standard GOST 6032  
(fill for heat exchangers where steel grade 08X18H10T, 12X18H10T, 10X17HI3M2T, 08X22H6T is applied)





# «Gas-Gas» Type Heat Exchangers





“Gas-gas” type heat-exchangers are designed for gas cooling in natural and associated petroleum gas treatment plants.

Heat exchangers can be operated in the conditions of temperate climatic region according to the Standard GOST 16350-80 with the average temperature of the coldest five-days minimum  $-40^{\circ}\text{C}$  in climatic design Y, placement category 1 as to Standard GOST 15150-69.

Technical requirements to materials, manufacture, acceptance, testing methods and preservation of apparatuses per SOU MPP 71.120-217:2009, GOST R 52630 and Technical Regulation of Customs Union 032/2013.

Heat exchangers are horizontal one-or two-staged counterflow shell and tubes units with U-shaped heat transferring tubes, two-passes through tube and shell side.

By design heat exchangers are divided into four types:

- type 1 - one-stage without injection of hydrate inhibitor;
- type 2 - one-stage with injection of hydrate inhibitor;
- type 3 - two-stage without injection of hydrate inhibitor;
- type 4 - two-stage with injection of hydrate inhibitor.

To prevent hydrate formation hydrate inhibitor is injected into tube side of 3 and 4 type heat exchangers, which is sprayed uniformly into all heat transferring tubes with centrifugal sprayers.

The cooled gas is supplied to the tube side and cold gas is supplied to the shell side.

Heat exchangers are manufactured of two material design:

M1 - for media with volume ratio:  $\text{CO}_2$  - up to 1%,  $\text{H}_2\text{S}$  - max. 0.001 %;

M2 - for media with volume ratio:  $\text{CO}_2$  - до 2%,  $\text{H}_2\text{S}$  - max. 0.001%.

Material of assembly units and parts: shell - steel 09Г2С; flanges, nozzles, tube sheets - forging of steel 20, 10Г2, 09Г2С; heat transferring tubes of diameter 20x2 or 20x2.5 (length of straight section 6 or 9 m) - steel 20 (material design M1) or steel 08Х22Н6Т (material design M2).

When installing heat exchangers should be thermally insulated.

### Description

“Gas-gas” heat exchanger, one-stage, of diameter 600 mm; design pressure, MPa ( $\text{kgf}/\text{cm}^2$ ): in tube side 16 (160); in shell side 8.8 (88); length of tube nest - 6 m; material design - M1.

#### “Gas-gas” heat exchanger 1-600-16/8.8-6-M1.

The same material design M2:

#### “Gas-gas” heat exchanger 1-600-16/8.8-6-M2.

When ordering heat exchanger product designation and Specification (TU 26-02-928-81) should be specified after description.



# 113 “Gas-Gas” Type Heat Exchangers

## Technical Data

Heat exchanger description	Pressure, MPa (kgf/cm <sup>2</sup> )				Heat transfer area at tubes OD, m <sup>2</sup>	Weight, kg
	design		working			
	in tube side	in shell side	in tube side	in shell side		
1-600-16/8.8-6-M1	16(160)	8.8(88)	13.8(138)	8,0(80)	145	8940
1-600-16/8.8-6-M2						
1-600-16/8.8-9-M1	16(160)	8.8(88)	13.8(138 )	8,0(80)	218	11410
1-600-16/8.8-9-M2						
1-600-11/6.4-6-M1	11(110)	6.4(64)	10(100)	5,8(58)	145	7550
1-600-11/6.4-6-M2						
1-600-11/6.4-9-M1	11(110)	6.4(64)	10(100)	5,8(58)	218	9830
1-600-11/6.4-9-M2						
1-600-6.4/6.4-6-M1	6.4(64)	6.4(64)	5.8(58)	5,8(58)	145	6400
1-600-6.4/6.4-6-M2						
1-600-6.4/6.4-9-M1	6.4(64)	6.4(64)	5.8(58)	5,8(58)	218	8470
1-600-6.4/6.4-9-M2						
2-600-16/8.8-6-M1	16(160)	8.8(88)	13.8(138)	8,0(80)	145	9100
2-600-16/8.8-6-M2						
2-600-16/8.8-9-M1	16(160)	8.8(88)	13.8(138)	8,0(80)	218	12570
2-600-16/8.8-9-M2						
2-600-11/6.4-6-M1	11(110)	6.4 (64)	10(100)	5,8(58)	145	7710
2-600-11/6.4-6-M2						
2-600-11/6.4-9-M1	11(110)	6.4 (64)	10(100)	5,8(58)	218	9990
2-600-11/6.4-9-M2						
2-600-6.4/6.4-6-M1	6.4 (64)	6.4 (64)	5.8 (58)	5,8(58)	145	6560
2-600-6.4/6.4-6-M2						
2-600-6.4/6.4-9-M1	6.4 (64)	6.4 (64)	5.8 (58)	5,8(58)	218	8630
2-600-6.4/6.4-9-M2						
3-600-16/8.8-6-M1	16(160)	8.8(88)	13.8(138)	8,0(80)	290	18190
3-600-16/8.8-6-M2						



# 114 “Gas-Gas” Type Heat Exchangers

Continuation sheet

Heat exchanger description	Pressure, MPa (kgf/cm <sup>2</sup> )				Heat transfer area at tubes OD, m <sup>2</sup>	Weight, kg
	design		working			
	in tube side	in shell side	in tube side	in shell side		
3-600-16/8.8-9-M1	16(160)	8.8(88)	13.8(138)	8(80)	436	23130
3-600-16/8.8-9-M2						
3-600-11/6.4-6-M1	11(110)	6.4(64)	10(100)	5.8(58)	290	15430
3-600-11/6.4-6-M2						
3-600-11/6.4-9-M1	11(110)	6.4(64)	10(100)	5.8(58)	436	20010
3-600-11/6.4-9-M2						
3-600-6.4/6.4-6-M1	6.4(64)	6.4(64)	5.8(58)	5.8(58)	290	13230
3-600-6.4/6.4-6-M2						
3-600-6.4/6.4-9-M1	6.4(64)	6.4(64)	5.8(58)	5.8(58)	436	17360
3-600-6.4/6.4-9-M2						
4-600-16/8.8-6-M1	16(160)	8.8(88)	13.8(138)	8(80)	290	18500
4-600-16/8.8-6-M2						
4-600-16/8.8-9-M1	16(160)	8.8(88)	13.8(138)	8(80)	436	23450
4-600-16/8.8-9-M2						
4-600-11/6.4-6-M1	11(110)	6.4(64)	10(100)	5.8(58)	290	15750
4-600-11/6.4-6-M2						
4-600-11/6.4-9-M1	11(110)	6.4(64)	10(100)	5.8(58)	436	20330
4-600-11/6.4-9-M2						
4-600-6.4/6.4-6-M1	6.4(64)	6.4(64)	5.8(58)	5.8(58)	290	13550
4-600-6.4/6.4-6-M2						
4-600-6.4/6.4-9-M1	6.4(64)	6.4(64)	5.8(58)	5.8(58)	436	17680
4-600-6.4/6.4-9-M2						
1-800-16/8.8-6-M1	16(160)	8.8(88)	13.8(138)	8(80)	250	16950
1-800-16/8.8-6-M2						
1-800-16/8.8-9-M1	16(160)	8.8(88)	13.8(138)	8(80)	385	20890
1-800-16/8.8-9-M2						



# 115 "Gas-Gas" Type Heat Exchangers

Continuation sheet

Heat exchanger description	Pressure, MPa (kgf/cm <sup>2</sup> )				Heat transfer area at tubes OD, m <sup>2</sup>	Weight, kg
	design		working			
	in tube side	in shell side	in tube side	in shell side		
1-800-11/6.4-6-M1	11(110)	6.4 (64)	10(100)	5.8(58)	250	13440
1-800-11/6.4-6-M						
1-800-11/6.4-9-M1	11(110)	6.4 (64)	10(100)	5.8(58)	385	17480
1-800-11/6.4-9-M						
1-800-6.4/6.4-6-M1	6.4(64)	6.4(64)	5.8(58)	5.8(58)	250	11610
1 -800-6.4/6.4-6-M2						
1 -800-6.4/6.4-9-M1	6.4 (64)	6.4(64)	5.8(58)	5.8(58)	385	15560
1-800-6.4/6.4-9-M2						
2-800-16/8.8-6-M1	16(160)	8.8(88)	13.8(138)	8(80)	250	17110
2-800-16/8.8-6-M2						
2-800-16/8.8-9-M1	16(160)	8.8(88)	13.8(138)	8(80)	385	21050
2-800-16/8.8-9-M2						
2-800-11 /6.4-6-M1	11(110)	6.4(64)	10(100)	5.8(58)	250	13600
2-800-11/6.4-6-M2						
2-800-11/6.4-9-M1	11(110)	6.4(64)	10(100)	5.8(58)	385	17650
2-800-11/6.4-9-M2						
2-800-6.4/6.4-6-M1	6.4(64)	6.4(64)	5.8(58)	5.8(58)	250	11770
2-800-6.4/6.4-6-M2						
2-800-6.4/6.4-9-M1	6.4(64)	6.4(64)	5.8(58)	5.8(58)	385	15720
2-800-6.4/6.4-9-M2						
3-800-16/8.8-6-M1	16(160)	8.8(88)	13.8(138)	8(80)	500	33860
3-800-16/8.8-6-M2						
3-800-16/8.8-9-M1	16(160)	8.8(88)	13.8(138)	8(80)	770	41740
3-800-16/8.8-9-M2						
3-800-11/6.4-6-M1	11(110)	6.4(64)	10(100)	5.8(58)	500	26960
3-800-11/6.4-6-M2						



# 116 "Gas-Gas" Type Heat Exchangers

Continuation sheet

Heat exchanger description	Pressure, MPa (kgf/cm <sup>2</sup> )				Heat transfer area at tubes OD, m <sup>2</sup>	Weight, kg
	design		working			
	in tube side	in shell side	in tube side	in shell side		
3-800-11/6.4-9-M1	11(110)	6.4(64)	10(100)	5.8(58)	770	35050
3-800-11/6.4-9-M2						
3-800-6.4/6.4-6-M1	6.4(64)	6.4(64)	5.8(58)	5.8(58)	500	23550
3-800-6.4/6.4-6-M2						
3-800-6.4/6.4-9-M1	6.4(64)	6.4(64)	5.8(58)	5.8(58)	770	31450
3-800-6.4/6.4-9-M2						
4-800-16/8.8-6-M1	16(160)	8.8(88)	13.8(138)	8(80)	500	34180
4-800-16/8.8-6-M2						
4-800-16/8.8-9-M1	16(160)	8.8(88)	13.8(138)	8(80)	770	42060
4-800-16/8.8-9-M2						
4-800-11/6.4-6-M1	11(110)	6.4(64)	10(100)	5.8(58)	500	27280
4-800-11/6.4-6-M2						
4-800-11/6.4-9-M1	11(110)	6.4(64)	10(100)	5.8(58)	770	35370
4-800-11/6.4-9-M2						
4-800-6.4/6.4-6-M1	6.4(64)	6.4(64)	5.8(58)	5.8(58)	500	23870
4-800-6.4/6.4-6-M2						
4-800-6.4/6.4-9-M1	6.4(64)	6.4(64)	5.8(58)	5.8(58)	770	31770
4-800-6.4/6.4-9-M2						
1-1000-16/8.8-6-M1	16(160)	8.8(88)	13.8(138)	8(80)	430	25380
1-1000-16/8.8-6-M2						
1-1000-16/8.8-9-M1	16(160)	8.8(88)	13.8(138)	8(80)	645	32240
1-1000-16/8.8-9-M2						
1-1000-11/6.4-6-M1	11(110)	6.4(64)	10(100)	5.8(58)	430	20920
1-1000-11/6.4-6-M2						
1-1000-11/6.4-9-M1	11(110)	6.4(64)	10(100)	5.8(58)	645	27250
1-1000-11/6.4-9-M2						



# 117 "Gas-Gas" Type Heat Exchangers

Continuation sheet

Heat exchanger description	Pressure, MPa (kgf/cm <sup>2</sup> )				Heat transfer area at tubes OD, m <sup>2</sup>	Weight, kg
	design		working			
	in tube side	in shell side	in tube side	in shell side		
1-1000-6.4/6.4-6-M1	6.4(64)	6.4(64)	5.8(58)	5.8(58)	430	17400
1-1000-6.4/6.4-6-M2						
1-1000-6.4/6.4-9-M1	6.4(64)	6.4(64)	5.8(58)	5.8(58)	645	23060
1-1000-6.4/6.4-9-M2						
2-1000-16/8.8-6-M1	16(160)	8.8(88)	13.8(138)	8(80)	430	25540
2-1000-16/8.8-6-M2						
2-1000-16/8.8-9-M1	16(160)	8.8(88)	13.8(138)	8(80)	645	32400
2-1000-16/8.8-9-M2						
2-1000-11/6.4-6-M1	11(110)	6.4(64)	10(100)	5.8(58)	430	21080
2-1000-11/6.4-6-M2						
2-1000-11/6.4-9-M1	11(110)	6.4(64)	10(100)	5.8(58)	645	27410
2-1000-11/6.4-9-M2						
2-1000-6.4/6.4-6-M1	6.4(64)	6.4(64)	5.8(58)	5.8(58)	430	17560
2-1000-6.4/6.4-6-M2						
2-1000-6.4/6.4-9-M1	6.4(64)	6.4(64)	5.8(58)	5.8(58)	645	23220
2-1000-6.4/6.4-9-M2						
3-1000-16/8.8-6-M1	16(160)	8.8(88)	13.8(138)	8(80)	860	51760
3-1000-16/8.8-6-M2						
3-1000-16/8.8-9-M1	16(160)	8.8(88)	13.8(138)	8(80)	1290	67490
3-1000-16/8.8-9-M2						
3-1000-11/6.4-6-M1	11(110)	6.4(64)	10(100)	5.8(58)	860	42840
3-1000-11/6.4-6-M2						
3-1000-11/6.4-9-M1	11(110)	6.4(64)	10(100)	5.8(58)	1290	55500
3-1000-11/6.4-9-M2						
3-1000-6.4/6.4-6-M1	6.4(64)	6.4 (64)	5.8(58)	5.8(58)	800	35790
3-1000-6.4/6.4-6-M2						
3-1000-6.4/6.4-9-M1	6.4(64)	6.4 (64)	5.8(58)	5.8(58)	1290	47120
3-1000-6.4/6.4-9-M2						



# 118 "Gas-Gas" Type Heat Exchangers

Continuation sheet

Heat exchanger description	Pressure, MPa (kgf/cm <sup>2</sup> )				Heat transfer area at tubes OD, m <sup>2</sup>	Weight, kg
	design		working			
	in tube side	in shell side	in tube side	in shell side		
4-1000-16/8.8-6-M1	16(160)	8.8(88)	13.8(138)	8(80)	860	52080
4-1000-16/8.8-6-M2						
4-1000-16/8.8-9-M1	16(160)	8.8(88)	13.8(138)	8(80)	1290	97810
4-1000-16/8.8-9-M2						
4-1000-11/6.4-6-M1	11(110)	6.4(64)	10(100)	5.8(58)	860	43160
4-1000-11/6.4-6-M2						
4-1000-11/6.4-9-M1	11(110)	6.4(64)	10(100)	5.8(58)	1290	55820
4-1000-11/6.4-9-M2						
4-1000-6.4/6.4-6-M1	6.4(64)	6.4(64)	5.8(58)	5.8(58)	860	36110
4-1000-6.4/6.4-6-M2						
4-1000-6.4/6.4-9-M1	6.4(64)	6.4(64)	5.8(58)	5.8(58)	1290	47440
4-1000-6.4/6.4-9-M2						
1-1200-16/8.8-9-M1	16(160)	8.8(88)	13.8(138)	8(80)	935	49740
1-1200-16/8.8-9-M2						
1-1200-11/8.8-9-M1	11(110)	6.4(64)	10(100)	5.8(58)	935	39550
1-1200-11/8.8-9-M2						
1-1200-6.4/6.4-9-M1	6.4(64)	6.4(64)	5.8(58)	5.8(58)	935	33420
1-1200-6.4/6.4-9-M2						
2-1200-16/8.8-9-M1	16(160)	8.8(88)	13.8(138)	8(80)	935	49900
2-1200-16/8.8-9-M2						
2-1200-11/6.4-9-M1	11(110)	6.4(64)	10(100)	5.8(58)	935	39710
2-1200-11/6.4-9-M2						
2-1200-6.4/6.4-9-M1	6.4(64)	6.4(64)	5.8(58)	5.8(58)	935	33580
2-1200-6.4/6.4-9-M2						
3-1200-16/8.8-9-M1	16(160)	8.8(88)	13.8(138)	8(80)	1870	100480
3-1200-16/8.8-9-M2						



# 119 "Gas-Gas" Type Heat Exchangers

Continuation sheet

Heat exchanger description	Pressure, MPa (kgf/cm <sup>2</sup> )				Heat transfer area at tubes OD, m <sup>2</sup>	Weight, kg
	design		working			
	in tube side	in shell side	in tube side	in shell side		
3-1200-11/6.4-9-M1	11(110)	6.4(64)	10(100)	5.8(58)	1870	80100
3-1200-11/6.4-9-M2						
3-1200-6.4/6.4-9-M1	6.4(64)	6.4(64)	5.8(58)	5.8(58)	1870	67820
3-1200-6.4/6.4-9-M2						
4-1200-16/8.8-9-M1	16(160)	8.8(88)	13.8(138)	8(80)	1870	100800
4-1200-16/8.8-9-M2						
4-1200-11/6.4-9-M1	11(110)	6.4(64)	10(100)	5.8(58)	1870	80420
4-1200-11/6.4-9-M2						
4-1200-6.4/6.4-9-M1	6.4(64)	6.4(64)	5.8(58)	5.8(58)	1870	68140
4-1200-6.4/6.4-9-M2						
1-1400-16/8.8-9-M1	16(160)	8.8(88)	13.8(138)	8(80)	1370	65200
1-1400-16/8.8-9-M2						
1-1400-11/6.4-9-M1	11(110)	6.4(64)	10(100)	5.8(58)	1370	54950
1-1400-11/6.4-9-M2						
2-1400-16/8.8-9-M1	16(160)	8.8(88)	13.8(138)	8(80)	1370	65360
2-1400-16/8.8-9-M2						
2-1400-11/6.4-9-M1	11(110)	6.4(64)	10(100)	5.8(58)	1370	55110
2-1400-11/6.4-9-M2						
3-1400-16/8.8-9-M1	16(160)	8.8(88)	13.8(138)	8(80)	2740	131430
3-1400-16/8.8-9-M2						
3-1400-11/6.4-9-M1	11(110)	6.4(64)	10(100)	5.8(58)	2740	110900
3-1400-11/6.4-9-M2						
4-1400-16/8.8-9-M1	16(160)	8.8(88)	13.8(138)	8(80)	2740	131750
4-1400-16/8.8-9-M2						
4-1400-11/6.4-9-M1	11(110)	6.4(64)	10(100)	5.8(58)	2740	111220
4-1400-11/6.4-9-M2						





## Materials for "gas-gas" type heat exchangers manufacturing and requirements to them:

- steel 09Г2С as to Standard GOST 5520-79 with mechanical properties after heat treatment not lower than:  $\sigma_b=4.6$  MPa (46 kgf/mm<sup>2</sup>),  $\sigma_T=2.8$  MPa (28 kgf/mm<sup>2</sup>),  $\sigma_5=21\%$ ,  $a_{KH}=30$  J/cm<sup>2</sup> (3 kgf m/cm<sup>2</sup>), at temperature 233 K (-40°C);

- steel BCТ3пс Standard GOST 380-71 with arsenic content max. 0.08%;

for material design M1:

- tubes as to Standard GOST 550-75 made of steel 20 and as to Standard GOST 8733-74 steel grade 10 Standard GOST 1050-74 with flow limit definition. Tubes should be tested for bending. Hydraulic test of each tube should be carried out.

for material design M2:

- tubes as to Standard GOST 9941-72 made of steel 08X18H10T Standard GOST 5632-72 sulfur content should not exceed 0.02%. Tubes should be hydraulically tested.

The rest of the materials used for manufacturing and requirements to them should comply to the materials and requirements specified in the Standard OST 26-291-94.

Notes:

1. Working medium temperature in tubes and shell up to 100°C.

2. Design corrosion allowance: in tube side - 4 mm; in shell side - 2 mm.

**Area of one pass clear opening  
depending on design pressure in tube side**

ID of heat exchanger $D_i$ , mm	Design pressure in tube side, MPa (kgf/cm <sup>2</sup> )	Diameter and thickness of heat transfer tubes, mm	Area of one pass clear opening, m <sup>2</sup>		ID of heat exchanger $D_i$ , mm	Design pressure in tube side, MPa (kgf/cm <sup>2</sup> )	Diameter and thickness of heat transfer tubes, mm	Area of one pass clear opening, m <sup>2</sup>	
			through heat transfer tubes	through shell side				through heat transfer tubes	through shell side
600	16(160)	20x2.5	0.034	0.075	1000	11(110)	20x2.5	0.101	0.203
	11(110)					20x2	0.115		
	6.4(64)	20x2	0.039	1200	16(160)	20x2.5	0.146		
800	16(160)	20x2.5	0.06	0.136	1200	11(110)	20x2	0.166	0.292
	11(110)					6.4(64)			
	6.4(64)	20x2	0.068	1400	16(160)	20x2.5	0.215	0.372	
1000	16(160)	20x2.5	0.101	0.203	11(110)				



# 121 Heat Exchanger of Type 1

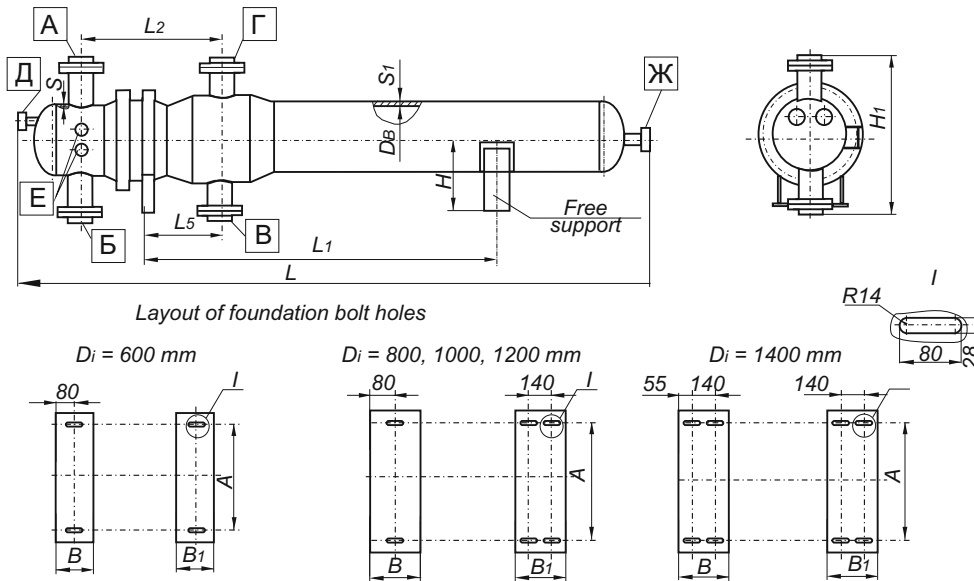

Basic and connection dimensions (mm) of heat exchangers of type 1

Description	S	S <sub>1</sub>	L	L <sub>1</sub>	L <sub>2</sub>	L <sub>3</sub>	H	H <sub>1</sub>	A	B	B <sub>1</sub>
1-600-16/8.8-6-M1	40	20	7930	4000	1465	725	730	1820	450	125	180
1-600-16/8.8-9-M1			10930	6000							
1-600-11/6.4-6-M1	26	16	7770	4000	1290	645	700	1760	450	120	
1-600-11/6.4-9-M1			10770	6000							
1-600-6.4/6.4-6-M1	20	16	7710	4000	1210	580	700	1695	450	100	
1-600-6.4/6.4-9-M1			10710	6000							
1-800-16/8.8-6-M1	55	25	8440	4000	1990	960	946	2360	500	170	250
1-800-16/8.8-9-M1			11440	6000							
1-800-11/6.4-6-M1	36	20	8100	4000	1600	805	886	2240	500	150	
1-800-11/6.4-9-M1			11100	6000							
1-800-6.4/6.4-6-M1	26	20	8045	4000	1485	715	866	2030	500	100	
1-800-6.4/6.4-9-M1			11045	6000							
1-1000-16/8.8-6-M1	65	32	8700	4000	2165	1045	1055	2580	650	195	
1-1000-16/8.8-9-M1			11700	6000							
1-1000-11/6.4-6-M1	45	25	8400	4000	1840	915	995	2450	650	185	
1-1000-11/6.4-9-M1			11400	6000							
1-1000-6.4/6.4-6-M1	32	25	3280	4000	1685	795	972	2240	650	125	
1-1000-6.4/6.4-9-M1			11280	6000							
1-1200-16/8.8-9-M1	80	36	12180	6000	2570	1250	1260	3100	800	230	
1-1200-11/6.4-9-M1	50	28	11760	6000	2115	1045	1230	3040	800	205	
1-1200-6.4/6.4-9-M1	40	28	11690	6000	1960	935	1170	2920	800	140	
1-1400-16/8.8-9-M1	95	45	12400	6000	2665	1320	1375	3330	950	250	
1-1400-11/6.4-9-M1	60	32	12085	6000	2350	1170	1340	3260	950	220	



# 122 Heat Exchanger of Type 2

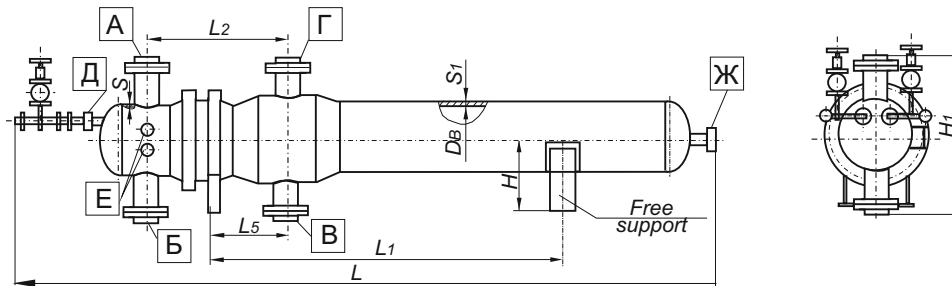

## Heat exchanger of type 2

(layout of foundation bolt holes is similar to layout for heat exchanger of type 1)

### Basic and connection dimensions (mm) of heat exchangers of type 2

Description	S	S <sub>1</sub>	L	L <sub>1</sub>	L <sub>2</sub>	L <sub>3</sub>	H	H <sub>1</sub>	A	B	B <sub>1</sub>
2-600-16/8.8-6-M1	40	20	8655	4000	1465	725	730	1820	450	125	180
2-600-16/8.8-9-M1			11655	6000							
2-600-11/6.4-6-M1	26	16	8495	4000	1290	645	700	1760	450	120	180
2-600-11/6.4-9-M1			11495	6000							
2-600-6.4/6.4-6-M1	20	16	8440	4000	1210	580	700	1695	450	100	180
2-600-6.4/6.4-9-M1			11440	6000							
2-800-16/8.8-6-M1	55	25	9165	4000	1990	960	946	2360	500	170	250
2-800-16/8.8-9-M1			12165	6000							
2-800-11/6.4-6-M1	36	20	8825	4000	1600	805	886	2240	500	150	250
2-800-11/6.4-9-M1			11825	6000							
2-800-6.4/6.4-6-M1	26	20	8775	4000	1485	715	866	2030	500	100	250
2-800-6.4/6.4-9-M1			11775	6000							
2-1000-16/8.8-6-M1	65	32	9425	4000	2165	1045	1055	2580	650	195	250
2-1000-16/8.8-9-M1			12425	6000							
2-1000-11/6.4-6-M1	45	25	9125	4000	1840	915	995	2450	650	185	250
2-1000-11/6.4-9-M1			12125	6000							
2-1000-6.4/6.4-6-M1	32	25	9010	4000	1685	795	972	2240	650	125	250
2-1000-6.4/6.4-9-M1			12010	6000							
2-1200-16/8.8-9-M1	80	36	12905	6000	2570	1250	1260	3100	800	230	250
2-1200-11/6.4-9-M1	50	28	12485	6000	2115	1045	1230	3040	800	205	250
2-1200-6.4/6.4-9-M1	40	28	12420	6000	1960	935	1170	2920	800	140	250
2-1400-16/8.8-9-M1	95	45	13125	6000	2665	1320	1375	3330	950	250	250
2-1400-11/6.4-9-M1	60	32	12810	6000	2350	1170	1340	3260	950	220	250



# 123 Heat Exchanger of Type 3

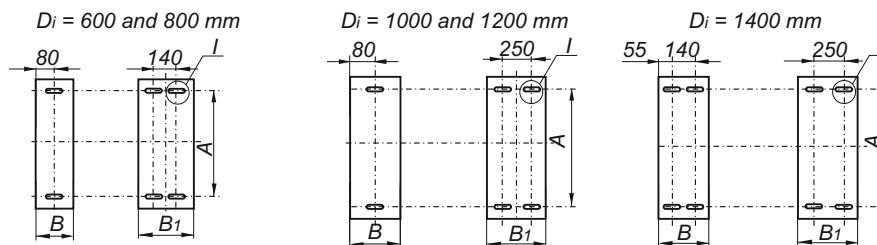
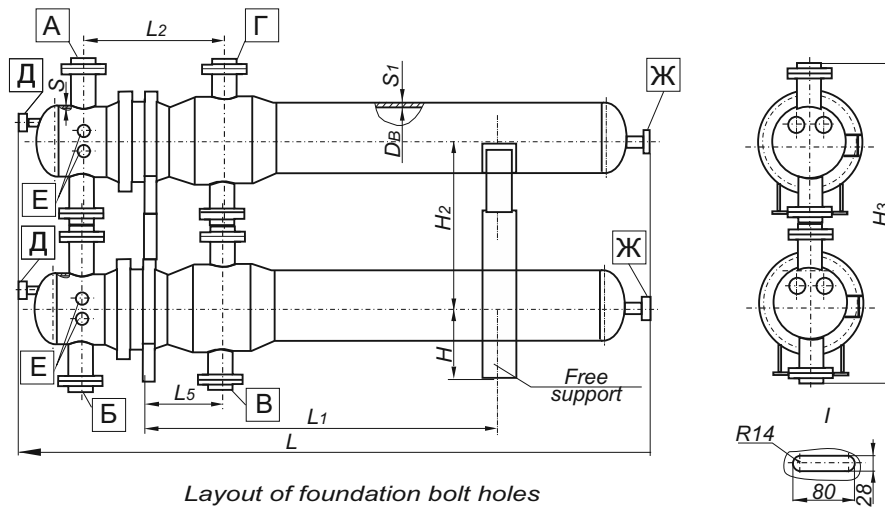

**Basic and connection dimensions (mm) of heat exchangers of type 3**

Description	S	S <sub>1</sub>	L	L <sub>1</sub>	L <sub>2</sub>	L <sub>3</sub>	H	H <sub>2</sub>	H <sub>3</sub>	A	B	B <sub>1</sub>
3-600-16/8.8-6-M1	40	20	7930	4000	1465	725	730	1468	3280	450	125	250
3-600-16/8.8-9-M1			10930	6000								
3-600-11/6.4-6-M1	26	16	7770	4000	1290	645	700	1408	3160	450	120	
3-600-11/6D-9-M1			10770	6000								
3-600-6.4/6.4-6-M1	20	16	7710	4000	1210	580	700	1407	3095	450	100	
3-600-6.4/6.4-9-M1			10710	6000								
3-800-16/8.8-6-M1	55	25	8440	4000	1990	960	946	1902	4250	500	170	
3-800-16/8.8-9-M1			11440	6000								
3-800-11/6.4-6-M1	36	20	8100	4000	1600	805	886	1782	4010	500	150	
3-800-11/6.4-9-M1			11100	6000								
3-800-6.4/6.4-6-M1	26	20	8045	4000	1485	715	866	1740	3760	500	100	
3-800-6.4/6.4-9-M1			11045	6000								
3-1000-16/8.8-6-M1	65	32	8700	4000	2165	1045	1055	2120	4690	650	195	350
3-1000-16/8.8-9-M1			11700	6000								
3-1000-11/6.4-6-M1	45	25	8400	4000	1840	915	995	2000	4440	650	185	
3-1000-11/6.4-9-M1			11400	6000								
3-1000-6.4/6.4-6-M1	32	25	8280	4000	1685	795	972	1951	4185	650	125	
3-1000-6.4/6.4-9-M1			11280	6000								
3-1200-16/8.8-9-M1	80	36	12180	6000	2570	1250	1260	2530	5620	800	230	
3-1200-11/6.4-9-M1	50	28	11760	6000	2115	1045	1230	2470	5500	800	205	
3-1200-6.4/6.4-9-M1	40	28	11690	6000	1960	935	1170	2347	5040	800	140	
3-1400-16/8.8-9-M1	95	45	12400	6000	2665	1320	1375	2760	6080	950	250	
3-1400-11/6.4-9M1	60	32	12085	6000	2350	1170	1340	2690	5940	950	220	



# 124 Heat Exchanger of Type 4

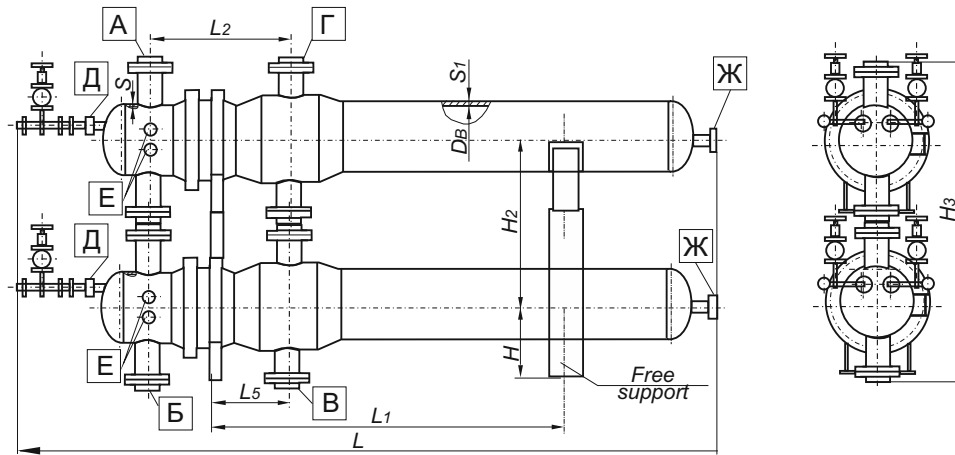

## Heat exchanger of type 4

(layout of foundation bolt holes is similar to layout for heat exchanger of type 3)

### Basic and connection dimensions (mm) of heat exchangers of type 4

Description	S	S <sub>1</sub>	L	L <sub>1</sub>	L <sub>2</sub>	L <sub>3</sub>	H	H <sub>2</sub>	H <sub>3</sub>	A	B	B <sub>1</sub>
4-600-16/8.8-6-M1	40	20	8655	4000	1465	725	730	1468	3280	450	125	250
4-600-16/8.8-9-M1			11655	6000								
4-600-11/6.4-6-M1	26	16	8495	4000	1290	645	700	1408	3160	450	120	
4-600-11/6.4-9-M1			11495	6000								
4-600-6.4/6.4-6-M1	20	16	8440	4000	1210	580	700	1407	3095	450	100	
4-600-6.4/6.4-9-M1			11440	6000								
4-800-16/8.8-6-M1	55	25	9165	4000	1990	960	946	1902	4250	500	170	
4-800-16/8.8-9-M1			12165	6000								
4-800-11/6.4-6-M1	36	20	8825	4000	1600	805	886	1782	4010	500	150	
4-800-11/6.4-9-M1			11825	6000								
4-800-6.4/6.4-6-M1	26	20	8775	4000	1485	715	866	1740	3760	500	100	
4-800-6.4/6.4-9-M1			11775	6000								
4-1000-16/8.8-6-M1	65	32	9425	4000	2165	1045	1055	2120	4690	650	195	
4-1000-16/8.8-9-M1			12425	6000								
4-1000-11/6.4-6-M1	45	25	9125	4000	1840	915	995	2000	4440	650	185	
4-1000-11/6.4-9-M1			12125	6000								
4-1000-6.4/6.4-6-M1	32	25	9010	4000	1685	795	972	1951	4185	650	125	
4-1000-6.4/6.4-9-M1			12010	6000								
4-1200-16/8.8-9-M1	80	36	12905	6000	2570	1250	1260	2530	5620	800	230	350
4-1200-11/6.4-9-M1	50	28	11485	6000	2115	1045	1230	2470	5500	800	205	
4-1200-6.4/6.4-9-M1	40	28	12420	6000	1960	935	1170	2347	5040	800	140	
4-1400-16/8.8-9-M1	95	45	13125	6000	2665	1320	1375	2760	6080	950	250	
4-1400-11/6.4-9-M1	60	32	12810	6000	2350	1170	1340	2690	5940	950	220	



# 125 Table of Nozzles

Heat exchanger description	А (inlet of wet gas)		Б (outlet of wet gas)		В (inlet of dried gas)		Г (outlet of dried gas)		Д* (stand-by)		Е* (stand-by)		Ж** (mounting)			
	Nominal pass (diameter) (mm) and nominal pressure MPa (kgf/cm <sup>2</sup> )															
	DN	PN	DN	PN	DN	PN	DN	PN	DN	PN	DN	PN	DN	PN		
600-16/8.8-6 600-16/8.8-9	200	16 (160)	200	16 (160)	200	10 (100)	200	10 (100)	50	16 (160)	25	16 (160)	80	10 (100)		
600-11/6.4-6 600-11/6.4-9														6.3 (63)	6.3 (63)	6.3 (63)
600-6.4/6.4-6 600-6.4/6.4-9														6.3(63)	6.3(63)	6.3(63)
800-16/8.8-6 800-16/8.8-9	300	16 (160)	300	16 (160)	300	10 (100)	300	10 (100)	50	16 (160)	25	16 (160)	80	10 (100)		
800-11/6.4-6 800-11/6.4-9														6.3 (63)	6.3 (63)	6.3 (63)
800-6.4/6.4-6 800-6.4/6.4-9														6.3(63)	6.3(63)	6.3(63)
1000-16/8.8-6 1000-16/8.8-9	300	16 (160)	300	16 (160)	300	10 (100)	300	10 (100)	50	16 (160)	25	16 (160)	80	10 (100)		
1000-11/6.4-6 1000-11/6.4-9														6.3 (63)	6.3 (63)	6.3 (63)
1000-6.4/6.4-6 1000-6.4/6.4-9														6.3(63)	6.3(63)	6.3(63)
1200-16/8.8-9	400	16 (160)	400	16 (160)	400	10(100)	400	10(100)	50	16 (160)	25	16 (160)	80	10(100)		
1200-11/6.4-9														6.3 (63)	6.3 (63)	6.3 (63)
1200-6.4/6.4-9														6.3(63)	6.3(63)	6.3(63)
1400-16/8.8-9	400	16 (160)	400	16 (160)	400	10(100)	400	10(100)	50	16 (160)	25	16 (160)	80	10(100)		
1400-11/6.4-9														6.3 (63)	6.3 (63)	6.3 (63)

\* For heat exchangers of types 2 and 4:  
 nozzle Д - for glycol injection (2 pc. — for single-stage heat exchangers, 4 pc. - for double-stage);  
 nozzle Е - for pressure drop measuring (2 pc. - for single-stage heat exchangers, 4 pc. - for double-stage).

\*\* For single-stage heat exchangers - 1 pc.;  
 for double-stage - 2 pc.



# **Vaporizers and Tube Bundles to Them**



Vaporizers are designed for processing media evaporation during the processes carried out in oil, chemical, petrochemical, gas and other industries and manufactured for domestic and overseas supply.

The units can be operated in micro climatic areas with temperate and tropical climate. Climatic design "U" and "T", product category 1 as to Standard GOST 15150.

The units are designed for installation in geographical regions of seismicity up to 7 points according to 12-points scale adopted in Ukraine.

Technical requirements to materials, manufacture, acceptance, testing methods and preservation of apparatuses per SOU MPP 71.120-217:2009, GOST R 52630 and Technical Regulation of Customs Union 032/2013.

The example of description of heat exchanger when ordering:

Vaporizer with vapor space, floating head (IP), shell of 1800 mm diameter, 1.6 MPa nominal pressure in shell, 2.5 MPa in tubes, material design M1, with heat transferring tubes of 25 mm diameter, 6 m length, 4-passes through tube-side, climatic design (U), with fitting components for thermal insulation:

**Vaporizer with vapor space 1800IP-1.6-2.5-M1/25-6-4-U-I Specification TU 3612-013-00220302-99.**

Vaporizer with vapor space, U-shape tubes (IU), shell of 1200 mm diameter, 2.5 MPa nominal pressure in shell, 2.5 MPa in tubes, material design M4, with heat transferring tubes of 20 mm diameter, 6 m length, 2-passes through tube-side, climatic design (T), without fitting components for thermal insulation:

**Vaporizer with vapor space 1200IU-2.5-2.5-M4/20-6-2-T Specification TU 3612-013-00220302-99.**

When ordering vaporizers the questionnaire in the form given below should be submitted.

At the Customer's request the following is allowed:

1. Install additional DN 80 mm nozzles, but max. 0.1 D, where D - vaporizer diameter;
2. Take reduced diameter of one or more nozzles (nozzle diameter increasing is not allowed);
3. The equipment and nozzles flanges facing to be tongue-and-groove;
4. Take the layout of supports in relation to nozzles different from layout between supports;

5. Fulfill fastening of tubes in tube sheets with flaring seal welding (in the absence of specific indication, the manufacturer chooses the type of tube connection to the tube sheets).

6. Do not install fitting components for thermal insulation.

Orders of vaporizers with above mentioned design changes should be carried out in the form given below.

Notes: It is allowed to manufacture vaporizers and tube bundles for specific design conditions, listed in the questionnaire or order form without sacrificing basic dimensions and material design as to description of the vaporizer to be ordered. In this case the weight of vaporizers is determined on the base of design pressure and temperature.

The example of tube bundle for heat exchanger when ordering:

Tube bundle (PT) for the vaporizer with vapor space, floating head (IP), shell of 1800 mm diameter, 1.6 MPa (the highest pressure in tubes and shell is specified), material design M1, with heat transferring tubes of 25 mm diameter, 6 m length, 4-passes through tube-side:

**Tube bundle PT 1800IP-1.6-M1/25-6-4 Specification TU 3612-013-00220302-99.**

Tube bundle (PT) for vaporizer with vapor space, U-shape tubes (IU), shell of 1200 mm diameter, 2.5 MPa nominal pressure, material design M4, with heat transferring tubes of 20 mm diameter, 6 m length, 2-passes through tube-side:

**Tube bundle PT 1200IU-2.5-M4/20-6-2 Specification TU 3612-013-00220302-99.**

When ordering tube bundles for heat exchangers the questionnaire in the form given below should be submitted.





Vaporizer of IU type

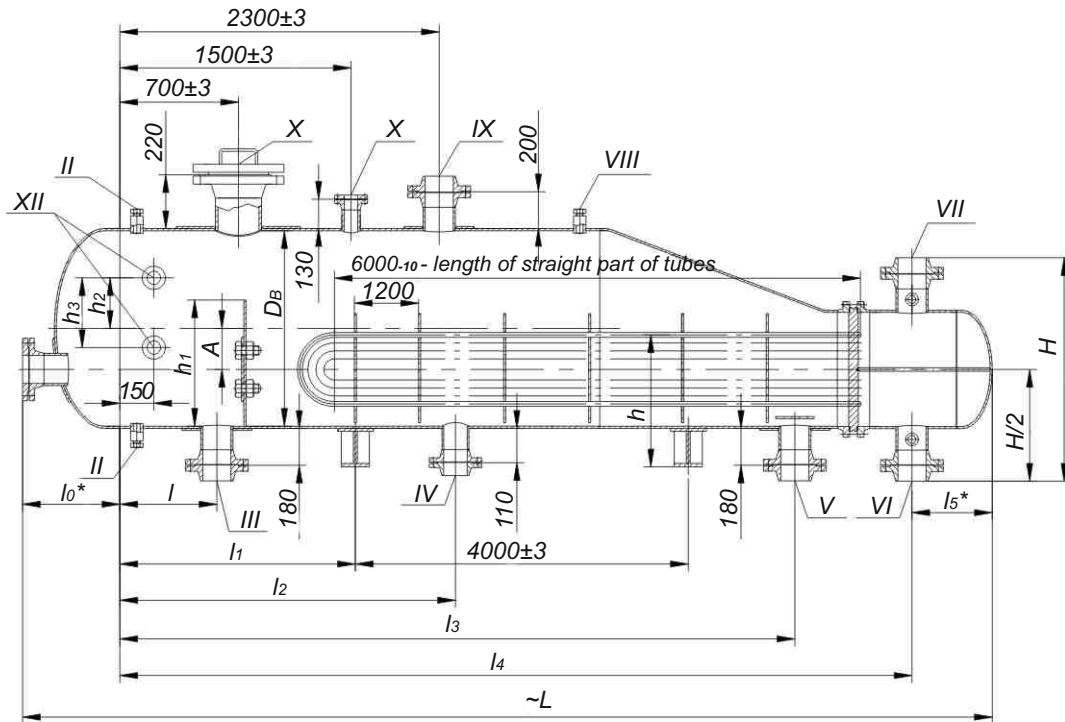

Nozzles Table

I	DN 200	For tube bundle installation
II	DN 40	For level indicator
III	DN4	Outlet of product rest
IV	DN 50	Drainage
V	DN3	Inlet of liquid product
VI	DN2	Outlet of vapor or liquid
VII	DN2	Inlet of vapor or liquid
VIII	DN 15	For pressure gauge
IX	DN1	Outlet of product vapor
X	DN 80	For safety valve
XI	DN 500	Manhole
XII	DN 50	For level indicator



Vaporizer of IP type

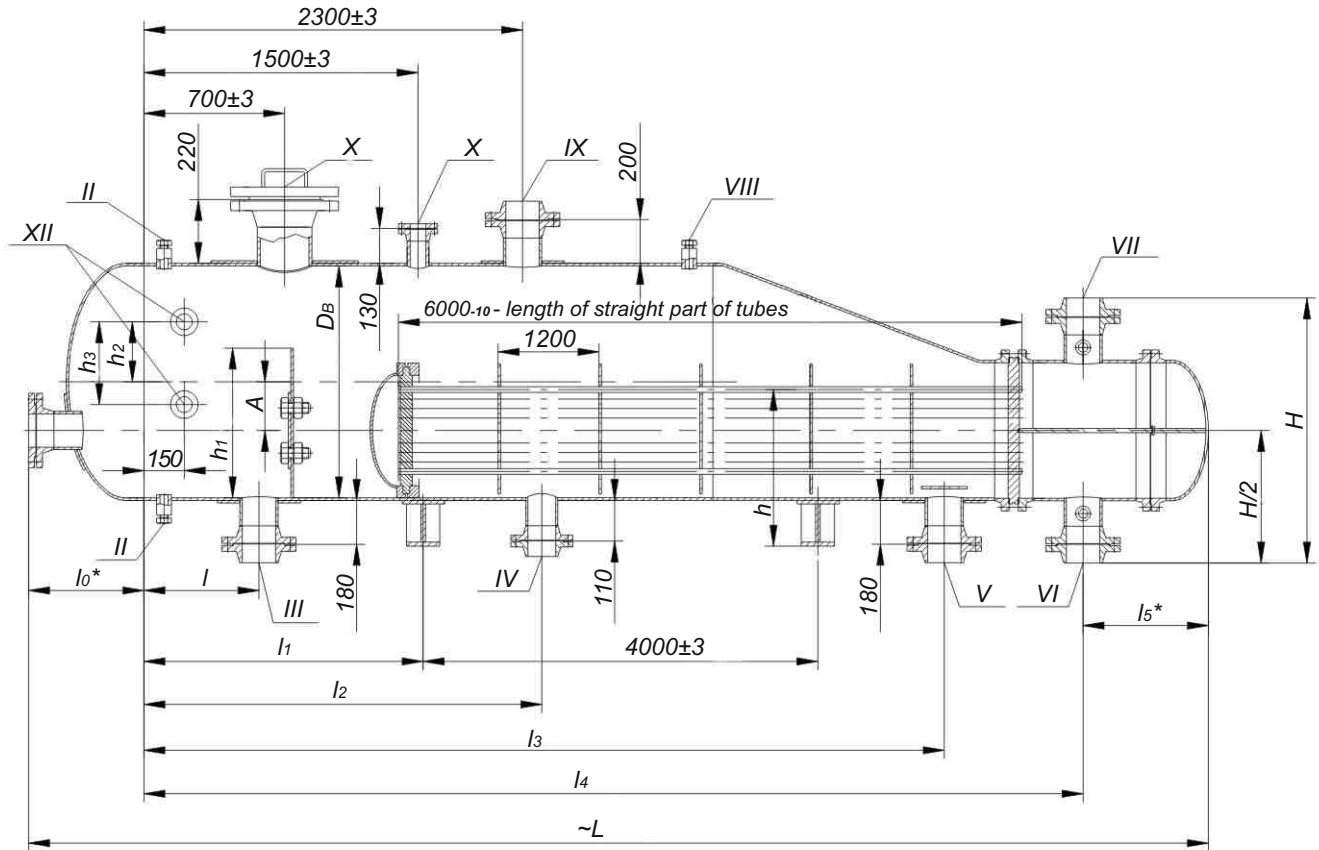

Nozzles Table

I	DN 200	For tube bundle installation
II	DN 40	For level indicator
III	DN4	Outlet of product rest
IV	DN 50	Drainage
V	DN3	Inlet of liquid product
VI	DN2	Outlet of vapor or liquid
VII	DN2	Inlet of vapor or liquid
VIII	DN 15	For pressure gauge
IX	DN1	Outlet of product vapor
X	DN 80	For safety valve
XI	DN 500	Manhole
XII	DN 50	For level indicator



# 130 Layout of Support Foundation Bolts Holes

## Layout of vaporizers support foundation bolts holes

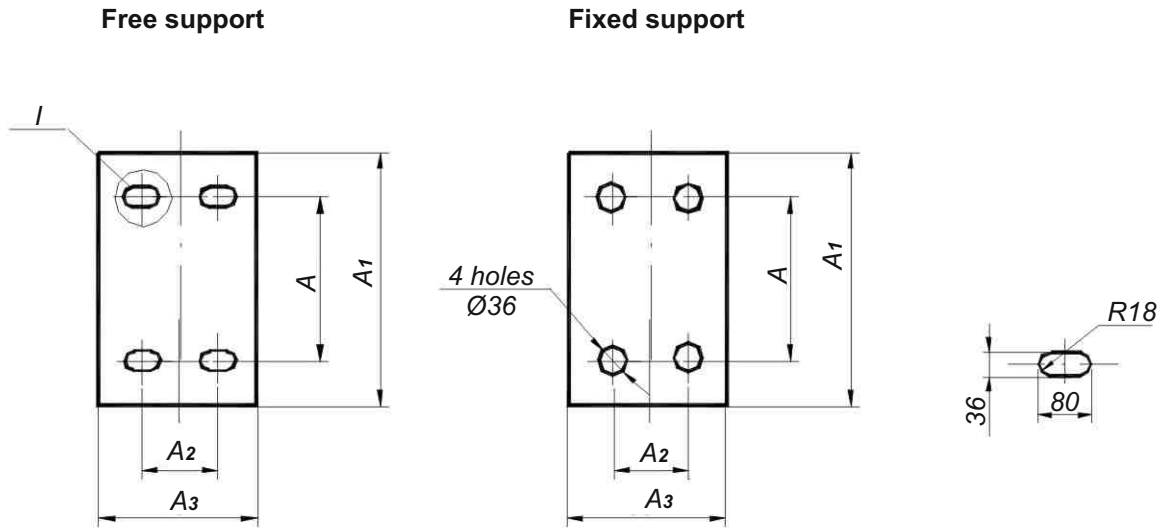

Dimensions, mm

Shell inner diameter, Di	A	A <sub>1</sub>	A <sub>2</sub>	A <sub>3</sub>
800	500	740	140	250
1000	650	1000		
1200	800	1100		
1400	950	1250	200	300
1600	1100	1420		
1800		1600		
2000	1500	1770		

### Maximum design pressure of heat exchangers depending on medium temperature

Nominal pressure PN, MPa	Maximum design pressure, MPa, at medium temperature, °C							
	до 100	200	250	300	350	400	425	450
1.0	1.00	0.93	0.90	0.75	0.66	0.58	0.50	0.36
1.6	1.60	1.49	1.40	1.20	1.10	0.90	0.80	0.57
2.5	2.50	2.32	2.25	1.90	1.70	1.50	1.30	0.90
4.0	4.00	3.72	3.50	3.00	2.60	2.30	2.00	1.40



# 131 Basic Parameters of Vaporizers with Vapor Space

Basic parameters of vaporizers with vapor space

Parameters	Parameters value for vaporizers	
	IP	IU
Heat transferring surface, m <sub>2</sub>	38-357	80-585
Shell inner diameter, mm (of sheet metal)	800;1000;1200;1400;1600;1800;2000	
Temperature of heating and evaporable media, (T <sub>5</sub> ), °C	from -30 up to +450	
Nominal pressure, MPa, max. in shell/tubes for units with diameter, mm:		
800	1.6 / 1.6 2.5 / 4.0	1.6 / 1.6 2.5 / 4.0
1000-1800	1.6 / 2.5 -	1.6 / 2.5 2.5 / 2.5
2000	1.0 / 1.6 1.6 / 1.6 -	1.0 / 1.6 1.6 / 1.6 2.5 / 1.6
Length of heat transferring tubes, mm	6000	
Outer diameter and wall thickness of heat transferring tubes, mm	25x2; 25x2.5	20x2
Number of passes through the tubes for units with diameter, mm		
800-1600	2	2
1800-2000	2; 4	
Layout of heat transferring tubes in tube sheets and partition walls	Layout - on square tops	



# 132 Vaporizers and Tube Bundles to Them

Dimensions, mm

Shell inner diameter, D <sub>1</sub> , mm	Inner diameter of distributing chamber, D <sub>1</sub> , mm	Pressure PN, MPa				H±6	H/2±3	h±3	h <sub>1</sub>	h <sub>2</sub>	h <sub>3</sub>	~L		l <sub>0</sub> *	l±3	l1±3	l2±3	l3±3	l4±3	I <sub>s</sub> *		A	DN <sub>1</sub>	DN <sub>2</sub>	DN <sub>3</sub>	DN <sub>4</sub>												
		For type		For type								IP	IU							For type	For type																	
		In shell	In tubes	IP	IU																						IP	IU										
																													In shell	In tubes								
800	500	1.6	2.5	4.0	884	442	616	565	245	370	8040	7900	460	1200	7120	460	320	150	250	300	200	200	150	150	200	100												
																											2.5	4.0	8220	7990	6390	7210	550	550	200	300	200	100
																											1.6	2.5	8530	8350	6280	7335	620	440	250	350	250	150
1000	600	1.6	2.5	984	492	716	665	1750	1200	1450	1750	1750	6300	7735	760	560	350	400	500	300	300	350	400	250	150													
																										1.6	2.5	9020	8820	6400	7690	700	500	250	400	300	150	
																																						1.6
																										1.6	2.5	9490	9280	6350	7950	780	570	400	500	350	400	
1200	700***	1.6	2.5	1088	544	816	765	1200	1000	1550	1000	1550	6300	7950	780	570	400	500	350	400	400	400	250	150														
																									1.6	2.5	8820	8620	6400	7690	700	500	250	400	300	150		
																																					1.6	2.5
																									1.6	2.5	9490	9280	6350	7950	780	570	400	500	350	400		
1400	800	1.6	2.5	1188	594	920	865	1200	1000	1550	1000	1550	6300	7950	780	570	400	500	350	400	400	250	150															
																								1.6	2.5	8820	8620	6400	7690	700	500	250	400	300	150			
																																				1.6	2.5	9200
																								1.6	2.5	9490	9280	6350	7950	780	570	400	500	350	400			
1600	900	1.6	2.5	1332	666	1020	965	1000	1550	1000	1550	1000	6300	7950	780	570	400	500	350	400	400	250	150															
																								1.6	2.5	8820	8620	6400	7690	700	500	250	400	300	150			
																																				1.6	2.5	9200
																								1.6	2.5	9490	9280	6350	7950	780	570	400	500	350	400			
1800	1000	1.6	2.5	1392	696	1124	1170	1000	1550	1000	1550	1000	6300	7950	780	570	400	500	350	400	400	250	150															
																								1.6	2.5	8820	8620	6400	7690	700	500	250	400	300	150			
																																				1.6	2.5	9200
																								1.6	2.5	9490	9280	6350	7950	780	570	400	500	350	400			
2000	1100	1.6	2.5	1492	746	355	1228	1000	1550	1000	1550	1000	6300	7950	780	570	400	500	350	400	400	250	150															
																								1.6	2.5	8820	8620	6400	7690	700	500	250	400	300	150			
																																				1.6	2.5	9200
																								1.6	2.5	9490	9280	6350	7950	780	570	400	500	350	400			
2000	1200	1.0	1.6	1694	847	1238	1300	1000	1550	1000	1550	1000	6300	7950	780	570	400	500	350	400	400	250	150															
																								1.6	2.5	8820	8620	6400	7690	700	500	250	400	300	150			
																																				1.6	2.5	9200
																								1.6	2.5	9490	9280	6350	7950	780	570	400	500	350	400			
2000	1200	1.0	1.6	1694	847	1238	1300	1000	1550	1000	1550	1000	6300	7950	780	570	400	500	350	400	400	250	150															
																								1.6	2.5	8820	8620	6400	7690	700	500	250	400	300	150			
																																				1.6	2.5	9200
																								1.6	2.5	9490	9280	6350	7950	780	570	400	500	350	400			



Heat transferring surface as to tubes outer diameter and clear opening area of IP and IU types vaporizers

Inner diameter of shell, $D_i$ , mm	Inner diameter of distributing chamber, $D_1$ , mm	Outer diameter of tubes, mm	Quantity of heat transferring tubes		Quantity of passes through the tubes	Heat transferring surface, $m^2$		Clear opening area of one pass through the tubes, $m^2$		
			for type			IP	IU	for type		
			IP	IU				2.0	2.5	2.0
800	500	20	-	104	-	80	-	-	-	0.021
		25	82	-	-	38	-	0.014	0.013	-
1000	600	20	-	155	-	120	-	-	-	0.031
		25	132	-	-	62	-	0.023	0.021	-
1200	700	20	-	226	-	176	-	-	-	0.045
		25	210	-	-	98	-	0.036	0.033	-
1400	800	20	-	295	2	231	-	-	-	0.059
		25	280	-	-	131	-	0.048	0.044	-
1600	900	20	-	389	-	306	-	-	-	0.078
		25	378	-	-	178	-	0.065	0.059	-
1800	1000	20	-	490	2	387	-	-	-	0.098
		25	490	-	-	230	-	0.084	0.077	-
1800	1000	20	-	-	4	-	-	-	-	-
		25	456	-	-	214	-	0.036	0.033	-
1800	1100	20	-	605	2	481	-	-	-	0.121
		25	632	-	-	297	-	0.109	0.099	-
2000	1100	20	-	-	4	-	-	-	-	-
		25	596	-	-	281	-	0.047	0.043	-
2000	1200	20	-	733	2	586	-	-	-	0.147
		25	758	-	-	357	-	0.131	0.119	-
2000	1200	20	-	-	4	-	-	-	-	-
		25	716	-	-	337	-	0.056	0.051	-

Note: Heat transferring surface is given without tube sheets thickness.



## Weight of IP and IU types Vaporizers

Inner diameter of shell, Di, mm	Inner diameter of distributing chamber, D1, mm	Pressure in shell PN, MPa	Pressure in tubes, MPa	Quantity of passes through the tubes	Weight of vaporizers, kg			
					For IP type		For IU type	
					tubes 25x2.0	tubes 25x2.5	tubes 20x2.0	
800	500	1.6	1.6		steel grades 08X18H10T, 12X18H10T, 10X17H13M2T, 08X13	steel grade 10, 20, 08X18H10T, 12X18H10T, 10X17H13M2T	3660	
		2.5	4.0		3120			
1000	600	1.6	2.5				3700	
		2.5	2.5				4600	
1200	700	1.6	2.5	2			6420	
		2.5	2.5				-	
1400	800	1.6	2.5				8890	
		2.5	2.5				-	
1600	900	1.6	2.5				9260	
		2.5	2.5				9890	
1800	1000	1.6	2.5				12950	
		2.5	2.5				13730	
	1100	1100	1.6	2.5	4			12920
			2.5	2.5				13690
1100	1100	1.6	2.5	2			14010	
		2.5	2.5				15045	
2000	1200	1.6	1.6	2			13970	
		2.5	1.6				15000	
1200	1200	1.0	1.6	4			-	
		2.5	1.6				17300	
1200	1200	1.0	2.5	2			15830	
		1.6	2.5				18300	
1200	1200	1.0	1.6	4			15790	
		1.6	1.6				17245	
		2.5	2.5				16740	
							-	
							18245	
							-	
							17510	
							18480	
							20100	
							-	
							-	
							-	

**Notes:**

1. Weight of vaporizers is calculated for steel with volume weight 7.85 g/cm<sup>3</sup>.
2. Weight of vaporizers is calculated for sheet metal nominal thickness without taking account the device for distributing chambers covers hanging.



Materials, applied for manufacture of assembly units of main components and parts of vaporizers and tube bundles

Type of vaporizer	Material design of vaporizer	Application temperature range, °C	Material					
			Shell	Distributing chamber	Tubes	Tube sheet	Shell gaskets	Distributing chamber gaskets
IP - IU	M1	from -30 to +450	Steel Cr3cn as to Standard GOST 380, GOST 14637. Steel 09Г2C as to Standard GOST 5520	Steel Cr3cn as to Standard GOST 380, GOST 14637. Steel 09Г2C as to Standard GOST 5520 Tubes - steel 20 as to Standard GOST 8731	Steel grades 10 and 20 as to Standard GOST 1050, GOST 550, gr. A, GOST 8733 gr. B	Steel 09Г2C as to Standard GOST 5520 or GOST 8479 gr. IV GOST 19281	Spiral-wound gaskets SNP Specifications TU U 2006 3327.002-200 Gaskets of the company Frenzelit (Novatec Premium; Novaphit VS, SSTS, EXTRA, SUPERHPS)	Spiral-wound gaskets SNP Specifications TU U 2006 3327.002-200 Gaskets of the company Frenzelit (Novatec Premium; Novaphit VS, SSTS, EXTRA, SUPERHPS)
	M4		Steel 15X5M or as to Standard GOST 550-75 gr. A	Steel 15X5M* as to Standard GOST 7350 gr. M26, GOST 8479 gr. IV and Technical Documents approved in accordance with established procedure	Spiral-wound gaskets SNP Specifications TU U 2006 3327.002-200 Gaskets of the company Frenzelit (Novatec Premium; Novaphit VS, SSTS, EXTRA, SUPERHPS)	Spiral-wound gaskets SNP Specifications TU U 2006 3327.002-200 Gaskets of the company Frenzelit (Novatec Premium; Novaphit VS, SSTS, EXTRA, SUPERHPS)		
IP	M13	from -30 to +350	Steel Cr3cn as to Standard GOST 380, GOST 14637. Steel 09Г2C as to Standard GOST 5520	Steel 08X18H10T or 12X18H10T as to Standard GOST 5632, GOST 9941	Steel 12X18H10T as to Standard GOST 7350 gr. M26, GOST 25054 gr. IV and Technical Documents approved in accordance with established procedure	Spiral-wound gaskets SNP Specifications TU U 2006 3327.002-200 Gaskets of the company Frenzelit (Novatec Premium; Novaphit VS, SSTS, EXTRA, SUPERHPS)	Spiral-wound gaskets SNP Specifications TU U 2006 3327.002-200 Gaskets of the company Frenzelit (Novatec Premium; Novaphit VS, SSTS, EXTRA, SUPERHPS)	
IU	M12	from -30 to +350	Steel Cr3cn as to Standard GOST 380, GOST 14637. Steel 09Г2C as to Standard GOST 5520	Steel 08X22H6T or 12X18H10T as to Standard GOST 5632, GOST 9941	Steel 09Г2C as to Standard GOST 5520 or GOST 8479 gr. IV GOST 19281 with stainless steel weld facing	Spiral-wound gaskets SNP Specifications TU U 2006 3327.002-200 Gaskets of the company Frenzelit (Novatec Premium; Novaphit VS, SSTS, EXTRA, SUPERHPS)	Spiral-wound gaskets SNP Specifications TU U 2006 3327.002-200 Gaskets of the company Frenzelit (Novatec Premium; Novaphit VS, SSTS, EXTRA, SUPERHPS)	
	M13		Steel Cr3cn as to Standard GOST 380, GOST 14637. Steel 09Г2C as to Standard GOST 5520	Steel 08X18H10T or 12X18H10T as to Standard GOST 5632, GOST 9941	Steel 12X18H10T as to Standard GOST 7350 gr. M26, GOST 25054 gr. IV and Technical Documents approved in accordance with established procedure	Sheet asbestos as to GOST 2850 In shell of M-HT-08X18H10T steel as to GOST 4986		





# 136 Two-Passes Tube Bundles for Vaporizers of IU Type

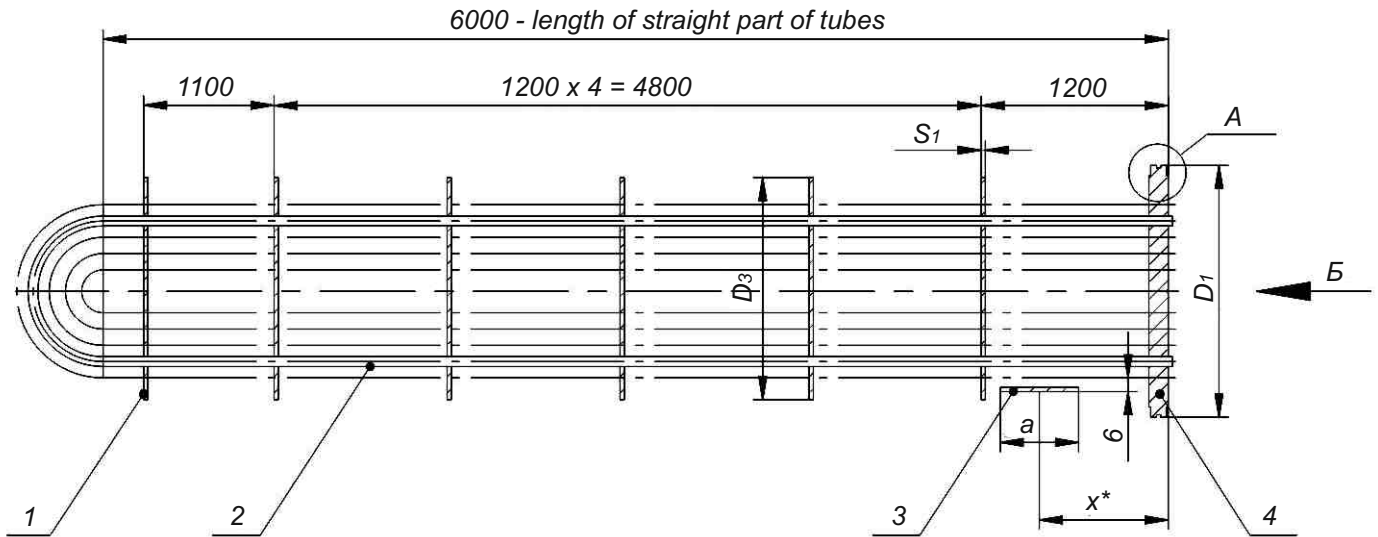

1 - partition wall; 2 - heat transferring tube; 3 - baffle plate; 4 - tube sheet.

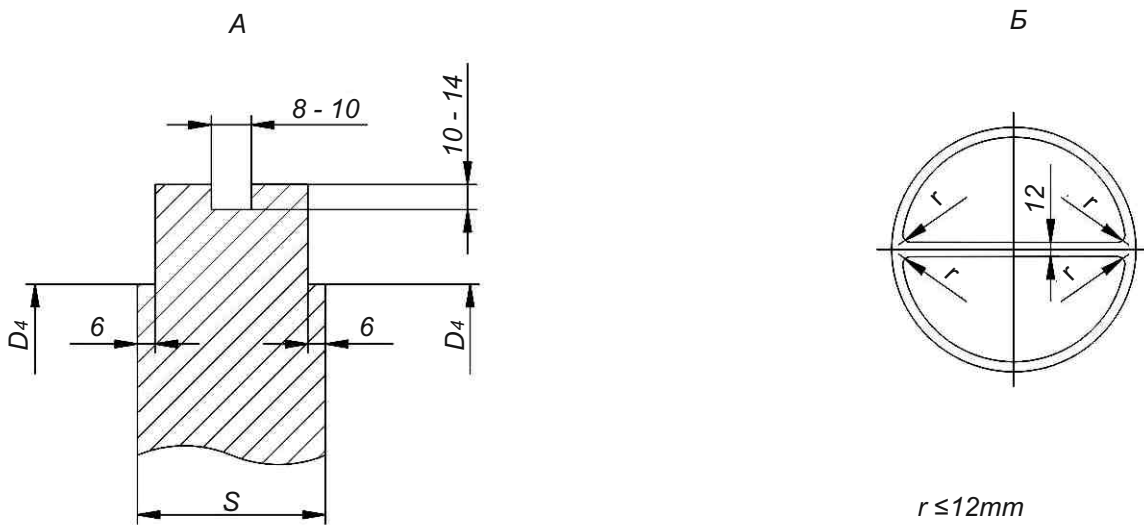

Note:  $x^*$ - baffle plate location is specified at the site



# 137 Two-Passes Tube Bundles for Vaporizers of IP Type

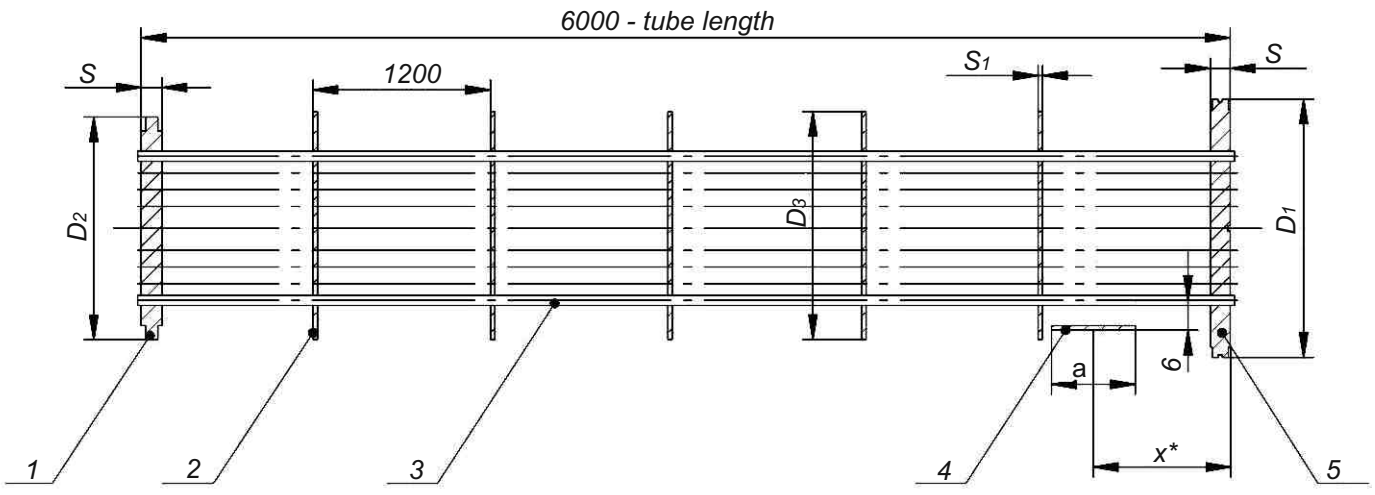

Four-passes tube bundles for vaporizers of IP type

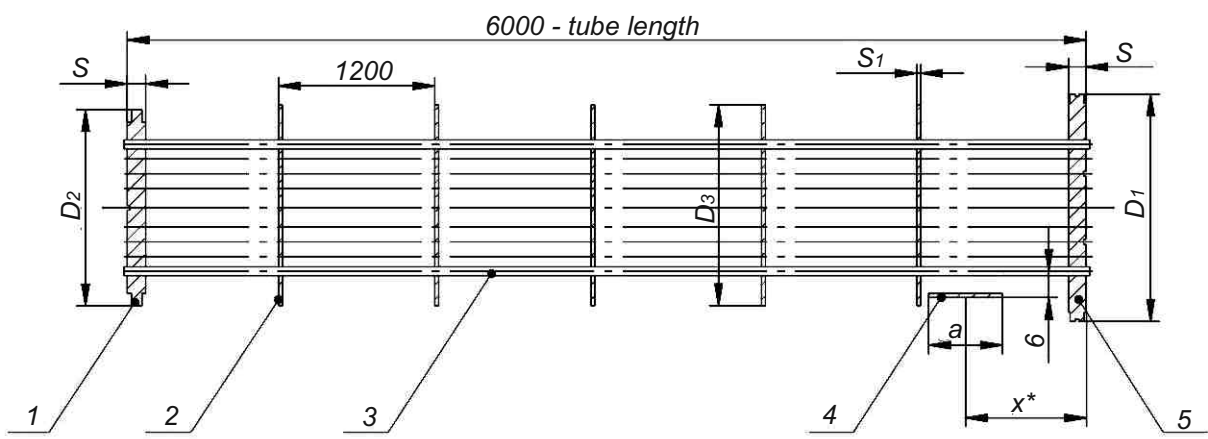

1 - flexible sheet; 2 - partition wall; 3 - tube heat transferring; 4 - baffle plate; 5 - tube sheet.



Basic dimensions of tube bundles for vaporizers of IP and IU types

Dimensions, mm

Inner diameter of shell, D <sub>i</sub> , mm	Inner diameter of distributing chamber D <sub>1</sub> , mm	Pressure PN, MPa				D <sub>1</sub>	D <sub>2</sub>	D <sub>3</sub>	D <sub>4</sub>	D <sub>5</sub>	a	S		S <sub>1</sub>
		for type		in tubes								IP	IU	
		IP	IU	in shell	in tubes									
		in shell	in tubes	in shell	in tubes									
800	500*	2.5	4.0	1.6	2.5	4.0	396	496	372	250	40	50	10	
														2.5
1000	600*	1.6	2.5	1.6	1.6	663	496	596	470	250	45	65	10	
														-
1200	700*	1.6	2.5	1.6	1.6	773	592	695	568	250	55	75	10	
														-
1400	800	1.6	2.5	1.6	1.6	875	690	795	660	250	60	85	10	
														-
1600	900	1.6	2.5	1.6	1.6	977	790	895	760	250	65	90	10	
														-
1800	1000	1.6	2.5	1.6	1.6	1078	890	995	862	300	70	100	12	
														-
2000	1100	1.6	2.5	1.6	1.6	1188	990	1095	962	300	75	105	12	
														-
2000	1200	1.0	1.6	1.0	1.0	1266	1090	1195	1060	300	75	95	12	
														1.6
		-	-	2.5	2.5	1294					-	115		

\* It is allowed to make distributing chamber of tubes of 530, 630, 720 mm diameter.



Weight of tube bundles for vaporizers of IP and IU

Inner diameter of shell, D <sub>i</sub> , mm	Inner diameter of distributing chamber, D <sub>1</sub> , mm	Pressure in shell, P <sub>N</sub> , MPa	Pressure in tubes	Quantity of passes through tubes	Weight of tube bundles, kg			
					For IP type		For IU type	
					tubes 25x2.0	tubes 25x2.5	tubes 20x2.0	
800	500	1.6	1.6		Steel 08X18H10T, 12X18H10T	780	910	Steel 10, 20, 08X18H10T, 12X18H10T
		2.5	4.0			800	930	
1000	600	1.6	2.5	2		1180	1390	1980
		2.5	2.5			1820	2160	
1200	700	1.6	2.5	2		2530	2980	3830
		2.5	2.5			3260	3860	
1400	800	1.6	2.5	2		4220	5000	6320
		2.5	2.5			4020	4740	
1600	900	1.6	2.5	4		5410	6410	7840
		2.5	2.5			5200	6140	
1800	1000	1.0	1.6	2		6420	7620	9360
		1.6	1.6			6170	7300	
1800	1000	1.6	2.5	4		6170	7300	-
		2.5	2.5			6170	7300	
2000	1200	1.0	1.6	2		6170	7300	9550
		1.6	1.6			6170	7300	
2000	1200	1.0	1.6	4		6170	7300	-
		1.6	1.6			6170	7300	

**Notes:**

1. Weight of tube bundles is calculated for steel with volume weight 7.85 g/cm<sup>3</sup>.
2. Weight of tube bundles is calculated for sheet metal nominal thickness without taking account the device for distributing chambers covers hanging.



# Questionnaire for Order of Heat Exchanger as to Specification TY 3612-013-00220302-99

## Questionnaire for order of heat exchanger as to Specification TY 3612-013-00220302-99

1. Vaporizer Designation			
2.	Design and operating conditions Medium parameter	In tubes	In shell
2.1	Pressure, MPa $P_{working}$ $P_{design}$		
2.2	Working temperature, °C    inlet outlet		
2.3	Design temperature, °C		
2.4	Minimum allowed (negative) temperature of vaporizer wall under pressure, °C		
2.5	Average air temperature of the coldest five days at heat exchanger layout (site), °C, (fill for vaporizers to be installed outdoors or in unheated rooms)		
2.6	Working medium designation and percentage composition		
2.7	Physical state of medium (gas, vapor, liquid)		
2.8	Medium characteristics: harmfulness as to standard GOST 12.1.007 (indicating the hazard class) - flammability as to standard GOST 12.1.004 "yes", "no" - explosive hazard as to standard GOST 12.1.011 (indicating mixture category and group)		
3.	Necessity of installation of parts for thermal insulation fixing "yes", "no" (delete as applicable)		
4.	Necessity of ICC testing of base metal and welded joints "yes", "no", if "yes" specify procedure as to standard GOST 6032_____ (fill for heat exchangers where steel grade 08X18H10T, 12X18H10T, 10X17H13M2T is applied)		
5.	Specify: pivot points "left", "right", "not required" (delete as applicable) (fill only for vaporizers with distributing chamber diameter 600 - 1200 mm)		
6.	Horizontal heat exchangers are installed: "on concrete foundation", "on metal structures" (delete as applicable)		

Questionnaire is not subject to be agreed

Name of the Company-User and process plant or line

\_\_\_\_\_

Name and postal address of the Company that filled Questionnaire \_\_\_\_\_

Signature of the head of the Company that filled Questionnaire \_\_\_\_\_

\_\_\_\_\_

\_\_\_\_\_

(title)

\_\_\_\_\_

(date)

\_\_\_\_\_

(signature)



# Order Form for Heat Exchanger Manufacturing as to Specifications TY 3612-013-00220302-99

## Order form of heat exchanger as to Specifications TY 3612-013-00220302-99 with design changes, required by these Specifications

1.	Standard heat exchanger designation		
2.	Design and operating conditions Medium parameter	in tubes	in shell
2.1.	Pressure, MPa $P_{working}$ $P_{design}$		
2.2.	Working temperature, °C inlet outlet		
2.3.	Design temperature, °C		
2.4.	Minimum allowed (negative) temperature of heat exchanger wall under pressure, °C		
2.5.	Average air temperature of the coldest five days at heat exchanger layout (site), °C, (fill for heat exchangers to be installed outdoors or in unheated rooms)		
2.6.	Working medium designation and percentage composition		
2.7.	Physical state of medium (gas, vapor, liquid)		
2.8.	Medium characteristics: - harmfulness as to standard GOST 12.1.007 (indicating the hazard class) - flammability as to standard GOST 12.1.004 "yes", "no" - explosive hazard as to standard GOST 12.1.011 (indicating mixture category and group)		
3.	Necessity of installation of parts for thermal insulation fixing "yes", "no" (delete as applicable)		
4.	Necessity of ICC testing of base metal and welded joints "yes", "no", if "yes" specify procedure as to standard GOST 6032 _____ (fill for heat exchangers where steel grade 08X18H10T, 12X18H10T, 10X17H13M2T is applied)		
5.	Specify: pivot points "left", "right", "not required" (delete as applicable) (fill only for vaporizers with distributing chamber diameter 600 -1200 mm)		
6.	Specify type of tube fastening in sheets: "expanding", «seal welding with expanding" (delete as applicable)		
7.	Heat exchangers are installed: «on concrete foundation", "on metal structures" (delete as applicable)		
8.	Nozzles		<u>Notes:</u> 1. Nominal bores are specified when they are smaller than those that specified in these Specifications. 2. When flange connection designation is not specified, counter flange is installed on nozzles
	Index	Nominal bore	
9.	The content of adopted differences from heat exchanger prototype as to Specifications TU 3612-013-00220302-99		
10.	Adopted differences reason		
11.	Order Form for heat exchanger manufacturing as to Specification TU 3612-013-00220302-99 with design changes is not subject to be agreed		

Questionnaire is not subject to be agreed

Name of the Company-User and process plant or line

Name and postal address of the Company that filled Questionnaire \_\_\_\_\_

Signature of the head of the Company that filled Questionnaire \_\_\_\_\_

\_\_\_\_\_ (title)

\_\_\_\_\_ (date)

\_\_\_\_\_ (signature)



# Order Form for Heat Exchanger Tube Bundles Manufacturing as to Specifications TY 3612-013-00220302-99

## Order Form for Heat Exchanger Tube Bundles Manufacturing as to Specifications TY 3612-013-00220302-99

1.	Tube bundles designation		
2.	Design and operating conditions Medium parameter	in tubes	in shell
2.1.	Pressure, MPa $P_{working}$ $P_{design}$		
2.2.	Working temperature, °C    inlet outlet		
2.3.	Design temperature, °C		
2.4.	Minimum allowed (negative) temperature of heat exchanger wall under pressure, °C		
2.5.	Average air temperature of the coldest five days at heat exchanger layout (site), °C, <i>(fill for heat exchangers to be installed outdoors or in unheated rooms)</i>		
2.6.	Working medium designation and percentage composition		
2.7.	Physical state of medium (gas, vapor, liquid)		
2.8.	Medium characteristics: - harmfulness as to standard GOST 12.1.007 <i>(indicating the hazard class)</i> - flammability as to standard GOST 12.1.004 "yes", "no" - explosive hazard as to standard GOST 12.1.011 <i>(indicating mixture category and group)</i>		
3.	Necessaty of ICC testing of base metal and welded joints "yes", "no", if "yes" specify procedure as to standard GOST 6032 _____ <i>(fill for heat exchangers where steel grade 08X18H10T, 12X18H10T, 10X17H13M2T is applied)</i>		
4.	Outer diameter of fixed tube sheet		
5.	Thickness of fixed tube sheet		

Questionnaire is not subject to be agreed

Name of the Company-User and process plant or line

\_\_\_\_\_

Name and postal address of the Company that filled Questionnaire \_\_\_\_\_

Signature of the head of the Company that filled Questionnaire \_\_\_\_\_

\_\_\_\_\_

\_\_\_\_\_

(title)

\_\_\_\_\_

(date)

\_\_\_\_\_

(signature)



# Thermosyphon Vaporizers





Vaporizers are designed for evaporation of media in technological processes of oil, chemical, petrochemical, gas and other industries and are manufactured for domestic and overseas supply.

INT, IKT type vaporizers are manufactured of the following designs:

1 - vertical with liquid, gaseous, gas-vapor and vapor-liquid heating agent;

2 - vertical with steam heating agent.

IPT type vaporizers are manufactured:

- horizontal with heat transferring tubes length  $l=3000$  mm;

- horizontal with heat transferring tubes length  $l=6000$  mm.

Heat transferring bare tubes (G) are applied in vaporizers.

Vaporizers can be operated in macro climatic regions with temperate and tropic climate. climatic design is "U" and "T", product category 1 as to Standard GOST 15150.

Vaporizers are designed for installation in geographic regions with the seismicity max 7 points according to the 12-points scale adopted in RF.

Technical requirements to materials, manufacture, acceptance, testing methods and preservation of apparatuses per SOU MPP 71.120-217:2009, GOST R 52630 and Technical Regulation of Customs Union 032/2013.

The example of description of heat exchanger when ordering:

Thermosyphon vaporizer with fixed tube sheets (INT), design 1, shell of 800 mm diameter, 1.0 MPa nominal pressure in tubes, 2.5 MPa in shell, material design M1, with bare transferring tubes (G) of 25 mm diameter, 3 m length, one-pass through tubes, climatic design (U) with fitting components for thermal insulation:

### **Thermosyphon vaporizer**

**800 INT-1-1.0-2. 5-M1/25G-3-1-U-I**

**Specifications TU 3612-005-00220302-98**

Thermosyphon vaporizer with fixed tube sheets and temperature compensator on the shell (IKT), design 2, shell of 1400 mm diameter, 1.6 MPa nominal pressure in tubes and shell, material design M1, with bare transferring tubes (G) of 25 mm diameter, 4 m length, one-pass through tubes, climatic design (T) without fitting components for thermal insulation:

### **Thermosyphon vaporizer**

**1400 IKT-2-1.6-1.6-M1/25G-4-1-T**

**Specifications TU 3612-005-00220802-98**

Thermosyphon vaporizer with floating head (IpT), shell of 1200 mm diameter, 6.3 MPa nominal pressure in tubes, 2.5 MPa in shell, material design M1, with bare transferring tubes (G) of 25 mm diameter, 6 m length, two-passes through tubes, climatic design (U) with fitting components for thermal insulation (I):

### **Thermosyphon vaporizer**

**1200 IPT-6.3-2.5-M1/25G-6-2-U-I**

**Specifications TU 3612-005-00220302-98**

When ordering vaporizers the questionnaire in the form given below should be submitted.

At the Customer's request the following is allowed:

- install additional DN  $\leq 80$  mm nozzles, but max. 0.1 D, where D - vaporizer diameter;
- take reduced diameter of one or more nozzles (nozzle diameter increasing is not allowed);
- in INT, IKT types vaporizers install baffle plate at bottom nozzle instead of top one (when product bottom inlet in shell side of vaporizer);
- increase distance between partition walls in tube bundle, but max 1000 mm at corresponding change of partition wall cutoff value;
- the equipment and nozzles flanges facing to be tongue-and-groove, PN  $\leq 4.0$  MPa;
- fulfil fastening of tubes in tube sheets with flaring seal welding (in the absence of specific indication, the manufacturer chooses the type of tube connection to the tube sheets).
- do not install fitting components for thermal insulation.
- on horizontal vaporizers install pivot device to hang covers for vaporizers with shell diameter 600, 800 mm, PN  $< 6.3$  MPa, vaporizers with shell diameter 1000, 1200 mm, PN  $< 4.0$  MPa.



# 145 Basic Parameters of Thermosyphon Vaporizers

Parameter		Parameter value for vaporizers		
		INT	IKT	IPT
Heat exchanging surface, m <sup>2</sup>		40-1240		40-464
Shell inner diameter, mm (of sheet steel)		600; 800; 1000; 1200; 1400; 1600; 1800; 2000; 2200	600; 800; 1000; 1200; 1400	600; 800; 1000; 1200
Temperature of heating agent and evaporant (T±5), °C		from -70 up to +350		from -70 up to + 450
Nominal pressure, MPa, max in shell for vaporizers with diameter, mm	600-1000	1.0; 1.6; 2.5; 4.0	1.0; 1.6	1.6; 2.5; 4.0; 6.3
	1200	1.0; 1.6; 2.5		
	1400			
	1600-2000		-	
	2200	1.0; 1.6	-	
Nominal pressure, MPa, max in shell for vaporizers with diameter, mm	600-1000	1.0; 1.6; 2.5; 4.0	1.0; 1.6	1.6; 2.5
	1200	1.0; 1.6; 2.5		
	1400			
	1600-2000		-	
	2200	1.0; 1.6	-	
Heat transferring tubes length, mm for vaporizers with diameter, mm	600-1000	2000; 3000; 4000		3000; 6000
	1200-2200	3000; 4000		
Heat transferring tubes outer diameter and wall thickness, mm		25 x 2		25 x 2; 25 x 2.5
Passes through tubes number		1		2; 4; 6
Diagram and spacing of heat transferring tubes layout in tube sheets, mm		Diagram - on tops of equilateral triangles Spacing - 32		

**Note:** Allowed to manufacture vaporizer shell of tubes with outer diameter 630 mm.



Vaporizers of INT and IKT type- design 1

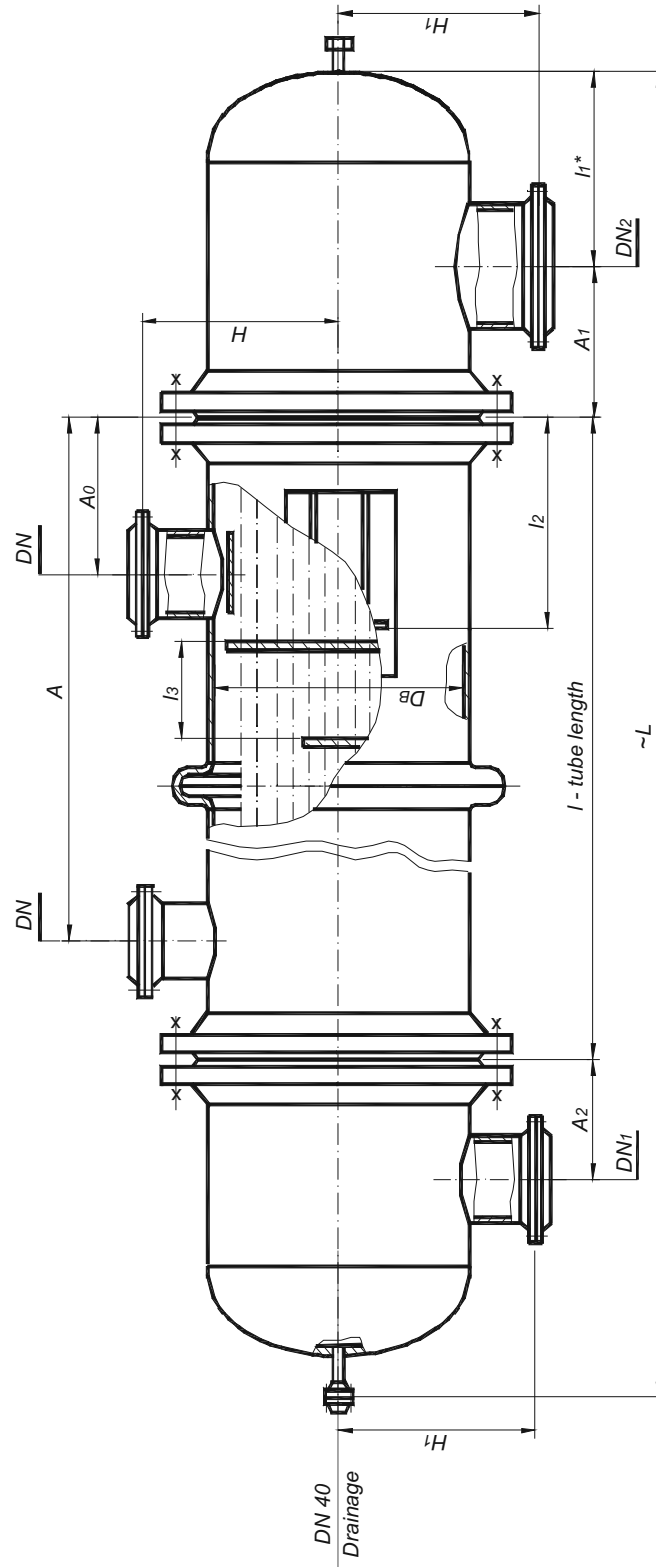

DN – inlet (outlet) of product  
 DN<sub>1</sub> – inlet of product  
 DN<sub>2</sub> – outlet of product vapour



Испарители типа ИНТ и ИКТ исполнения 2

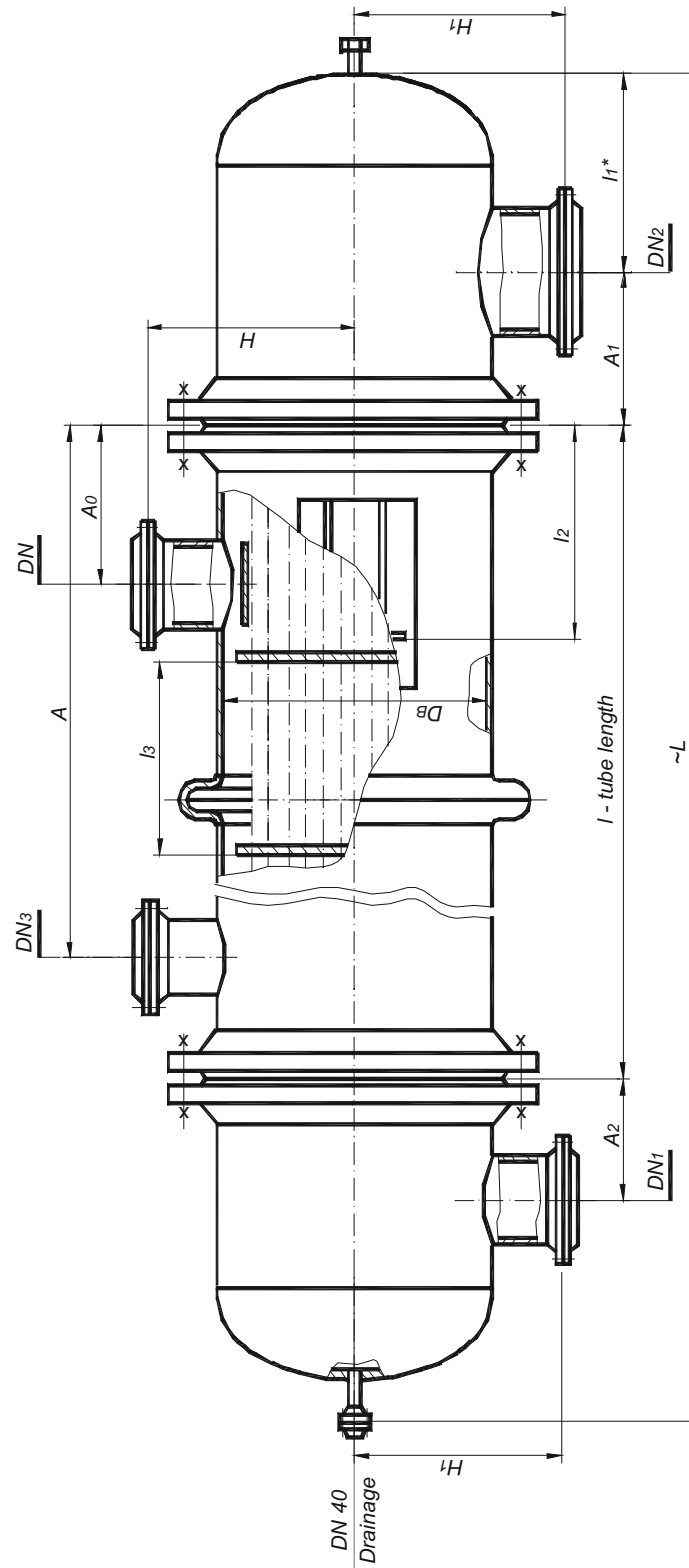

- DN – inlet of vapour
- DN1 – inlet of product
- DN2 – outlet of product vapour
- DN3 – outlet of condensate



Basic dimensions of INT-1, INT-2, IKT-1, IKT-2 vaporizers

Dimensions, mm

Shell inner diameter, D <sub>i</sub>	Pressure in tubes and shell, P <sub>n</sub> , MPa	I-K	A ± 5				A <sub>0</sub> ± 3		A <sub>1</sub> ± 3			A <sub>2</sub> ± 3			DN			DN <sub>2</sub>	I <sub>r</sub> *	I <sub>2</sub> ± 3	Partition walls layout				H ± 3	H <sub>r</sub> ± 3	≈ L
			For designs		For designs		1	2	1	2	1	2	For design		Quantity	I <sub>3</sub>	Quantity				I <sub>3</sub>	Quantity					
			1	2	1	2							1	2									1	2			
600	1.0	2000	1750	1830	280	395	325	400	275	490	275	5	275	2	3600												
			3000	2830												250	390	330	300	9	275	2	4600				
			4000	3830																				100	475	310	11
	2000	1750	270	435	380	200	5	275	2	3590																	
	3000	2750									275	490	310	11	2	3700											
	4000	3750															200	490	510	11	3	5700					
	2000	1725	275	460	360	400	7	260	2	4920																	
	3000	2725									300	475	310	11	2	5920											
	4000	3725															150	625	340	7	3	6920					
	2000	1700	340	500	400	250	5	260	2	4050																	
	3000	2700									275	500	300	300	9	340	2	5050									
	4000	3700																	200	640	705	11	2	6050			
2000	1735	325	520	465	250	5	260	2	4080																		
3000	2735									300	595	720	11	2	4080												
4000	3735															150	830	820	7	3	6080						
2000	1675	335	600	475	400	5	260	2	4080																		
3000	2675									325	640	805	11	2	5080												
4000	3675															200	785	900	7	3	6450						
2000	1750	350	640	515	300	3	450	2	4450																		
3000	2675									325	700	820	7	2	5450												
4000	3675															150	830	820	7	3	6450						
2000	1675	330	600	475	400	5	450	2	4450																		
3000	2675									300	785	900	7	2	5450												
4000	3675															200	805	910	7	3	6450						
2000	1650	345	640	515	300	3	450	2	4450																		
3000	2650									325	700	820	7	2	5450												
4000	3650															150	830	820	7	3	6450						
2000	1625	365	640	515	300	3	450	2	4450																		
3000	2625									325	785	910	7	2	5450												
4000	3625															200	805	910	7	3	6450						
2000	1685	375	640	515	300	3	450	2	4450																		
3000	2685									325	700	820	7	2	5450												
4000	3685															150	830	820	7	3	6450						



Continuation sheet

Shell inner diameter, Di	Pressure in tubes and shell, PN, MPa	I-K	A ±5		A0 ±3		A1 ±3		A2 ±3		DN		DN3		DN1	DN2	I1*	I2 ±3	Partition walls layout				H ±3	H1 ±3	≈L
			For designs		For designs		For design		For design		For design		For design						For design						
			1	2	1	2	1	2	1	2	1	2	1	2					1	2	Quantity	I3			
1200	1.0	3000	2600	2710	400	420	750	480	500	2	2	800	955	900	5	7	2	830	880	5860	6860	5860	6860		
	1.6	3000	2600	2660																				3660	685
1400	2.5	3000	2600	2645	375	405	780	615	350	350	250	900	1100	900	5	7	2	990	1030	6060	7060	6390	7290		
	1.0	3000	2625	2695																				3695	875
1600	1.6	3000	2625	2655	450	425	785	610	400	400	250	1000	1230	900	5	7	2	1090	1130	6310	7310	6530	7530		
	2.5	3000	2625	2630																				3630	880
1800	1.0	3000	2550	2610	475	510	890	650	400	400	300	800	1165	950	3	5	2	1090	1130	6850	7860	7200	8200		
	1.6	3000	2550	2575																				3575	915
2000	2.5	3000	2525	2540	520	550	1035	775	500	500	400	1100	1360	1050	3	5	2	1375	1430	7320	8320	7460	8460		
	1.0	3000	2525	2590																				3590	975
2200	1.6	3000	2480	2550	575	625	1085	900	700	700	400	1000	1345	1110	3	5	2	1345	1430	7460	8460	7500	8500		
	2.5	3000	2425	2475																				3475	1120
	1.0	3000	2380	2455	620	595	1190	970	500	500	400	1100	1480	1180	3	5	2	1480	1530	7830	8830	7970	8970		
	1.6	3000	2400	2500																				3455	1190
	2.5	3000	2400	2450	600	650	1195	915	600	600	400	1300	1675	1290	3	5	2	1675	1730	8080	9080	9080	9080		
	1.0	3000	2400	2450																				3450	1195

\*\* Pressure in shell. Pressure in tubes ≤ 2,5 MPa.

Notes:

1. Pressure in tubes must be less than pressure in shell. я в кожухе. If pressure in tubes is less than pressure in shell, dimensions A1, A0, I3, DN, DN3, H are chosen depending on pressure in shell, all other dimensions are chosen depending on pressure in tubes.
2. IKT-1, IKT-2 vaporizers are applied with shell of 600 - 1400 mm diameter, pressure DN ≤ 1.6 MPa.
3. At tube length 2000 and 3000 mm K=5, at tube length 4000 mm K=10.



IPT vaporizers with heat transferring tubes length  $l = 3000$  mm

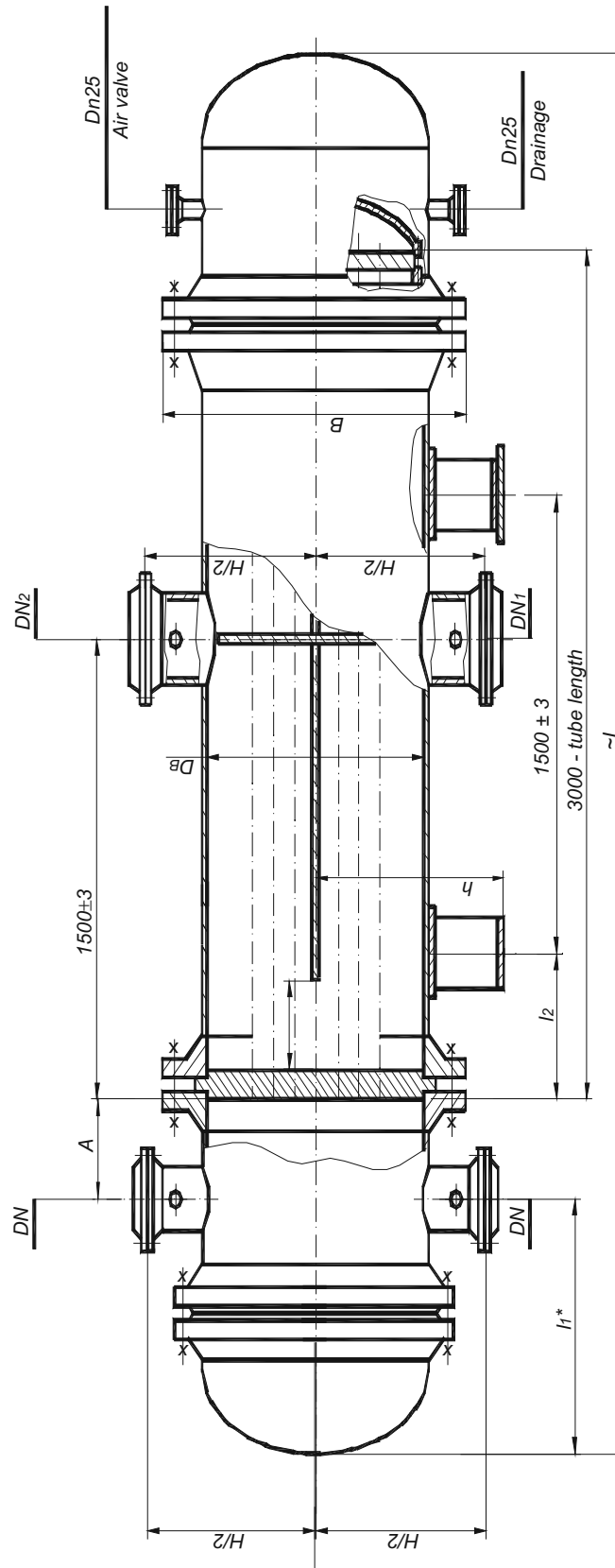

- DN – inlet (outlet) of heating agent
- DN1 – inlet of liquid product
- DN2 – outlet of product vapours



IPT vaporizers heat transferring tubes length  $l = 6000$  mm

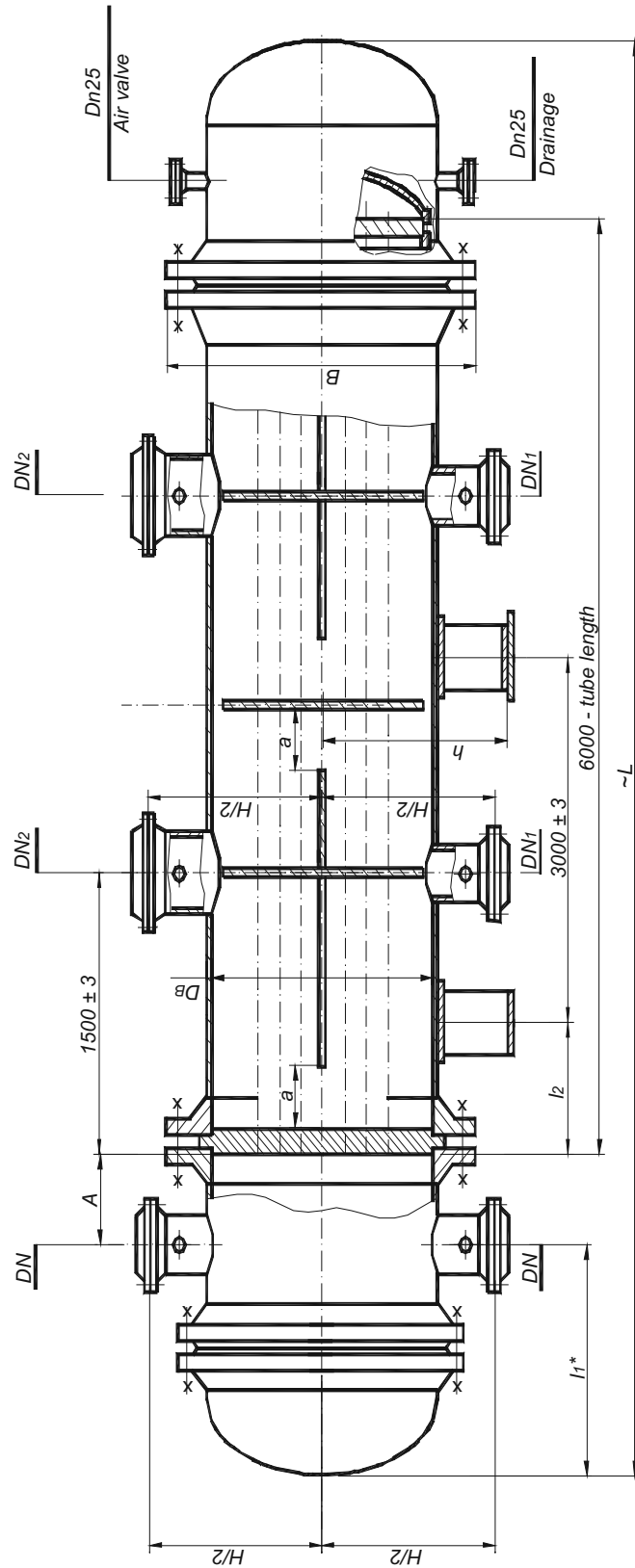

- DN — inlet (outlet) of heat agent
- DN1 — inlet of liquid product
- DN2 — outlet of product vapour





## Basic dimensions of IPT vaporizer with heat transferring tube length $l = 3000$ mm and $l = 6000$ mm

Dimensions, mm																	
Shell inner diameter $D_i$	Pressure PN, MPa		I-K	DN at passes through tubes quantity			$DN_1$	$DN_2$	$l_1^*$	$l_2 \pm 3$	$A \pm 3$	$a$	$H/2 \pm 3$	$h \pm 3$	$B^* \pm 3$	$\approx L$	
	in tubes	in shell		2	4	6											
600	1.6	1.6	3000	200	150	100	250	520	600	270	300	300	530	525	840	4100	
			6000						950							7100	
	2.5	2.5	3000	200	150	100	200	570	600	300	340	300	300	530	840	850	4200
			6000						950								7200
	4.0	1.6	3000	200	150	100	250	640	600	340	385	385	300	530	525	840	4310
			6000						950								7310
	6.3	2.5	3000	200	150	100	250	720	600	385	385	385	300	530	525	840	4340
			6000						950								7340
	800	1.6	1.6	3000	250	200	150	300	700	600	380	380	380	400	616	1045	4450
				6000						950							7465
	4.0	2.5	2.5	3000	250	200	150	250	725	600	385	385	385	400	677	1070	4490
				6000						950							7490
6.3	1.6	1.6	3000	250	200	150	300	780	600	395	395	400	677	616	1045	4520	
			6000						950							7520	
2.5	2.5	2.5	3000	250	200	150	250	920	600	475	475	400	677	616	1045	4570	
			6000						950							7570	
6.3	1.6	1.6	3000	250	200	150	300	920	600	475	475	400	677	616	1045	4590	
			6000						950							7590	
2.5	2.5	2.5	3000	250	200	150	250	920	600	475	475	400	677	616	1045	4800	
			6000						950							7800	
6.3	1.6	1.6	3000	250	200	150	250	920	600	475	475	400	677	616	1045	4820	
			6000						950							7820	



# Basic Dimensions of IPT Vaporizer with Tubes Length 3000 mm, 6000 mm

Shell inner diameter Di		Pressure PN, MPa		I-K	DN at passes through tubes quantity			DN <sub>1</sub>	DN <sub>2</sub>	I <sub>r</sub> *	I <sub>2</sub> ± 3	A ± 3	a	H/2 ± 3	h ± 3	B <sub>3</sub> <sup>±6</sup>	≈L				
					2	4	6														
1000	1.6	in tubes	3000	200	300	250	350	790	600	395	500	779	716	1250	4670	≈L					
			6000												7670						
	2.5	in shell	3000					200	300	250	350	830	600	420	500	779	716	1250	4710	≈L	
			6000																7710		
	1200	1.6	in tubes					3000	250	300	350	880	600	420	600	600	890	820	1550	7900	≈L
								6000												7950	
2.5		in shell	3000	250	300	250	350	940				455	600	600	890	820	1610	8030	≈L		
			6000															8100			
4.0		in tubes	3000	250	300	250	350	1150				590	900	600	890	820	1550	8180	≈L		
			6000															8270			
6.3	in shell	3000	250	300	250	350	1300	660	900	600	890	820	1610	8530	≈L						
		6000												8550							

Continuation sheet

Dimensions, mm



Heat exchange surface as to tubes outer diameter and area of clear openings through tube and shell sides of INT and IKT vaporizers

Shell inner diameter, Di, mm	Heat exchange surface, m <sup>2</sup> at tube length, mm			Area of clear opening of one pass through tubes, m <sup>2</sup>	Area of clear opening through shell side*, m <sup>2</sup>		
	2000	3000	4000		in slot	Between partition walls at tube length, mm	
					2000	3000	4000
600	40	60	80	0.088	0.045	0.048	0.054
800	74	112	149	0.164	0.070	0.058	0.068
1000	119	179	238	0.263	0.115	0.101	0.108
1200	-	262	350	0.386	0.170	-	0.123
1400	-	371	494	0.545	0.208	-	0.149
1600	-	479	639	0.704	0.293	-	0.243
1800	-	614	819	0.902	0.363	-	0.267
2000	-	756	1009	1.112	0.449	-	0.266
2200	-	930	1240	1.366	0.507	-	0.294

\* Area of clear opening through shell side is given for vaporizers of design 1.

Note: Heat exchange surface is given not including tube sheet thickness



# Heat Exchange Surface Along the Outside Pipe Diameter and the Area of Clear Openings in the Pipes of Floating Head Thermosyphon Evaporators (FHTE)

Shell inner diameter, Di, mm	Tubes assortment, mm	Quantity of passes through tubes	Heat exchange surface, m <sup>2</sup> at tube length, mm		Area of clear opening of one pass through tubes, m <sup>2</sup>
			3000	6000	
600	25x2 25x2.5	2	50	100	0.031 0.034
	25x2 25x2.5	4	44	88	0.011 0.012
	25x2 25x2.5	6	40	81	0.007 0.008
800	25x2 25x2.5	2	95	191	0.061 0.067
	25x2 25x2.5	4	86	172	0.027 0.030
	25x2 25x2.5	6	83	166	0.016 0.017
1000	25x2 25x2.5	2	155	310	0.101 0.111
	25x2 25x2.5	4	144	288	0.043 0.048
	25x2 25x2.5	6	139	279	0.027 0.030
1200	25x2 25x2.5	2	-	464	0.151 0.167
	25x2 25x2.5	4	-	435	0.064 0.071
	25x2 25x2.5	6	-	424	0.042 0.047

Note: Heat exchange surface is given not including tube sheet thickness

## Maximum design pressure of heat exchangers depending on medium temperature

Nominal pressure PN, MPa	Maximum design pressure, MPa, at medium temperature, °C							
	до 100	200	250	300	350	400*	425*	450*
1.0	1.00	0.93	0.90	0.75	0.66	0.58	0.50	0.36
1.6	1.60	1.49	1.40	1.20	1.10	0.90	0.80	0.57
2.5**	2.50	2.32	2.25	1.90	1.70	1.50	1.30	0.90
4.0**	4.00	3.72	3.50	3.00	2.60	2.30	2.00	1.40
6.3*	6.30	6.00	5.40	4.80	4.00	3.70	3.20	2.30

\* Only for FHTE-type machines.

\*\* Only for immovable tube sheet thermosiphon evaporators (ITTE) and FHTE-type machines



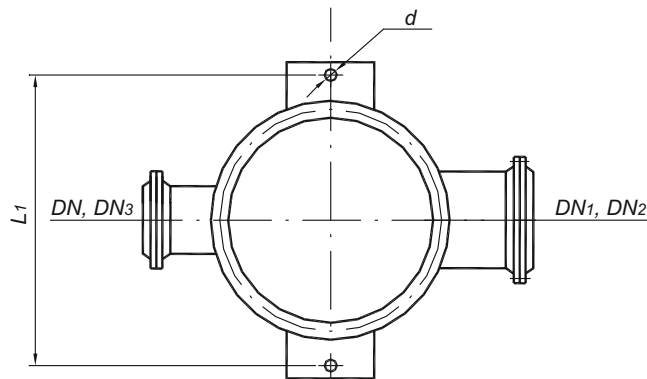

Dimensions, mm

Shell inner diameter, Di	Allowable load on landing pad, H	L1 ± 6	d
600	25000	1006	24
800	63000	1300	35
1000	100000	1538	42
1200		1812	
1400	160000	2020	
1600		2300	
1800	250000	2600	50
2000	400000	2900	
2200		3100	

### Layout of foundation bolts holes for IPT vaporizers

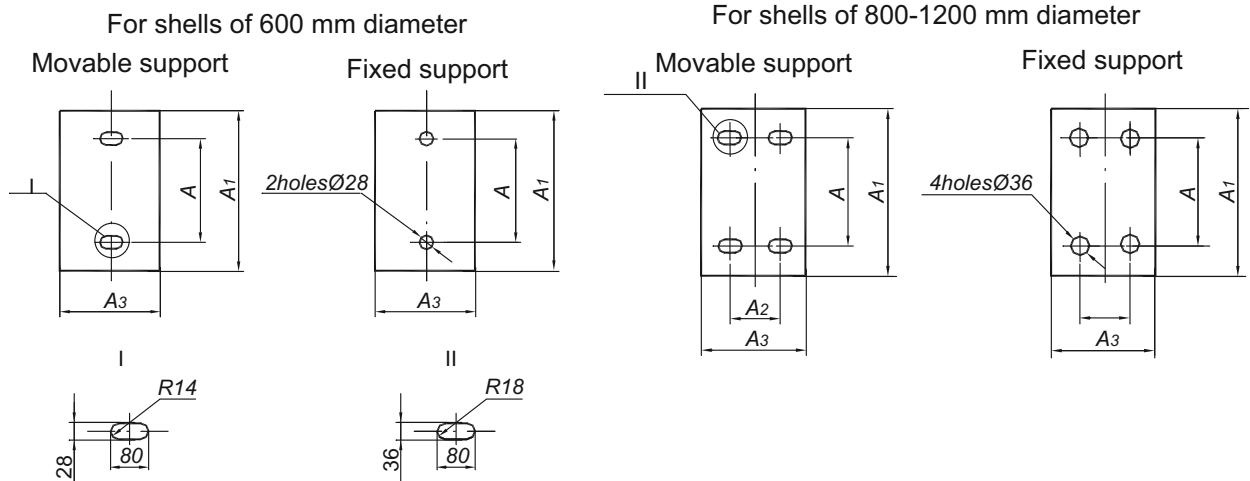

Dimensions, mm

Inner diameter, Di	A	A1	A2	A3
600	450	600	-	180
800	500	740	140	250
1000	650	1000		
1200	800	1100		



Materials for vaporizers assembly units, main parts and components manufacturing

Vaporizer type	Vaporizer material design	Application temperature limit, °C	Materials		
			shell and shell cover	distributing chamber	tubes
INT IKT IPT	M1	from -30 to +350	Steel Ct3cn as to Standard GOST 380, GOST 14637 Steel 16TC as to GOST 5520, Tubes - steel 20 as to Standard GOST 1050, GOST 8731 gr. B	Steel 10 and 20 as to Standard 1050, GOST 550 gr.A, GOST 8733 gr. B	Steel 16TC* as to GOST 5520 or GOST 8479 gr.IV, GOST 19281
		from -30 to +450			
INT IKT IPT	M8	from -70 to +350	Steel 12X18H10T as to GOST 5632 and GOST 7350 gr. M26	Steel 08X18H10T, 12X18H10T as to GOST 5632, GOST 9941	Steel 12X18H10T as to Standard GOST 5632 gr. M26, GOST 25054 gr. IV and Technical Documents approved in accordance with established procedure
INT IKT IPT	M9	from -70 to +350	Steel 10X17H13M2T as to GOST 5632 and GOST 7350 gr. M26	Steel 10X17H13M2T as to GOST 5632, GOST 9941	Steel 10X17H13M2T as to Standard GOST 5632, GOST 7350 gr. M26, GOST 25054 gr. IV and Technical Documents approved in accordance with established procedure
INT INK	M10		Steel 12X18H10T as to GOST 5632 and GOST 7350 gr. M26	Steel 08X18H10T, 12X18H10T as to GOST 5632, GOST 9941	Steel 12X18H10T as to Standard GOST 5632 gr. M26, GOST 25054 gr. IV and Technical Documents approved in accordance with established procedure
		from -30 to +200	Steel Ct 3cn as to Standard GOST 380, GOST 14637 Steel 16TC* as to GOST 5520	Steel 10X17H13M2T as to GOST 5632 and GOST 7350 gr. M26	Steel 10X17H13M2T as to Standard GOST 5632, GOST 7350 gr. M26, GOST 25054 gr. IV and Technical Documents approved in accordance with established procedure
	M11		Steel 10X17H13M2T as to GOST 5632 and GOST 7350 gr. M26	Steel 10X17H13M2T as to GOST 5632, GOST 9941	Steel 10X17H13M2T as to Standard GOST 5632, GOST 7350 gr. M26, GOST 25054 gr. IV and Technical Documents approved in accordance with established procedure



Continuation sheet

		Materials for vaporizers assembly units, main parts and components manufacturing			
		shell and shell cover	distributing chamber	tubes	tube sheet
Vaporizer type	INT IKT	Steel 09Г2С as to GOST 5520, GOST 19281. Tubes - steel 10Г2 as to GOST 8731 gr. B and Technical Documents approved in accordance with established procedure	Steel 10Г2 as to GOST 550 (gr. A), GOST 8733 (gr. B)	Steel 09Г2С and 10Г2С1 as to GOST 5520, 09Г2С as to GOST 1928 and 10Г2 as to GOST 4543, GOST 8479 gr. IV	
	IPT				
Vaporizer material design	M17	Steel Cr3cn as to GOST 380, GOST 4637 Tubes - steel 20 as to Standard GOST 1050, GOST 8731 gr. B	Steel 08X22H6T as to GOST 5632 and GOST 7350 gr. M26	Steel 08X22H6T as to GOST 5632 gr. M26, GOST 25054 gr. IV and Technical Documents approved in accordance with established procedure	
	M23**		Steel 08X22H6T as to GOST 5632 and GOST 7350 gr. M26	Steel 08X22H6T as to GOST 5632 gr. M26, GOST 25054 gr. IV and Technical Documents approved in accordance with established procedure	
Vaporizer material design	M24**	Steel 08X22H6T as to GOST 5632 and GOST 7350 gr. M26	Steel 08X22H6T as to GOST 5632 and GOST 7350 gr. M26	Steel 08X22H6T as to GOST 5632 gr. M26, GOST 25054 gr. IV and Technical Documents approved in accordance with established procedure	
			Steel 08X22H6T as to GOST 5632 and GOST 7350 gr. M26	Steel 08X22H6T as to GOST 5632 and GOST 7350 gr. M26	Steel 08X22H6T as to GOST 5632 gr. M26, GOST 25054 gr. IV and Technical Documents approved in accordance with established procedure
Application temperature limit, °C	from -60 to +350	from -30 to +200			
	from -60 to +450				

\*\* It is allowed to apply in agreement with manufacturer.

Note:

1. It is allowed to make out assembly units of another materials of grades provided in Industrial Standard OST 26-291, which correspond to materials specified in the table by mechanical properties and corrosion resistance.
2. All materials applied for vaporizers manufacturing must be certified.



# 159 Weight of INT and IKT Vaporizers

Shell inner diameter, Di, mm	Pressure in tubes, PN, MPa	Pressure in shell, PN, MPa	Weight, kg, at tube length, mm		
			2000	3000	4000
600	1.0	1.0	1450	1850	2260
		1.6	1480	1880	2280
		2.5	1560	1890	2420
	1.6	1.6	1565	1900	2430
		2.5	1570	1940	2440
	2.5	2.5	1710	2140	2570
4.0		2100	2500	2900	
800	1.0	1.0	2350	3020	3730
		1.6	2460	3170	3910
		2.5	2570	3290	4030
	1.6	1.6	2600	3300	4040
		2.5	2650	3370	4120
	2.5	2.5	2900	3630	4370
4.0		3400	4130	4900	
100	1.0	1.0	3900	4950	6100
		1.6	3980	5050	6400
		2.5	4200	5390	6600
	1.6	1.6	4350	5450	6650
		2.5	4450	5700	6700
	2.5	2.5	5000	6100	7250
4.0		5800	6800	7800	
1200	1.0	1.0	-	7000	8760
		1.6	-	7300	9300
		2.5	-	7410	9550
	1.6	1.6	-	8050	9980
		2.5	-	8300	10150
	2.5	2.5	-	9390	11300





Shell inner diameter, Di, mm	Pressure in tubes, PN, MPa	Pressure in shell, PN, MPa	Weight, kg, at tube length, mm		
			2000	3000	4000
1400	1.0	1.0	-	9940	12480
		1.6	-	10150	12880
		2.5	-	10800	13430
	1.6	1.6	-	11020	13580
		2.5	-	11440	14080
		2.5	-	13050	15410
1600	1.0	1.0	-	12420	15300
		1.6	-	12930	15850
		2.5	-	13520	16880
	1.6	1.6	-	13900	17000
		2.5	-	14590	17880
		2.5	-	16300	19200
1800	1.0	1.0	-	15380	19240
		1.6	-	16180	19940
		2.5	-	17380	20840
	1.6	1.6	-	18030	21620
		2.5	-	19230	23140
		2.5	-	20310	24320
2000	1.0	1.0	-	20000	24350
		1.6	-	20570	25080
		2.5	-	21320	27480
	1.6	1.6	-	22640	28000
		2.5	-	24400	29150
		2.5	-	26820	31570
2200	1.0	1.0	-	24900	28750
		1.6	-	26820	32450
	1.6	1.6	-	26940	34700

**Note:**

1. Weight of INT, IKT vaporizers is calculated for nominal thickness of sheet metal without weight of fitting and components.
2. Allowance from weight value must not exceed +8%.



# 161 Weight of IPT Vaporizers

Shell inner diameter, Di, mm	Pressure PN, MPa		Weight, kg			
			For 25x2 tubes of length		For 25x2.5 tubes of length	
	in tubes	in shell	3000	6000	3000	6000
600	<b>2 passes through tubes</b>					
	1.6	1.6	2500	3880	2670	4220
	2.5	1.6	2630	3960	2800	4330
		2.5	2780	4280	2950	4620
	4.0	1.6	3090	4460	3260	4800
		2.5	3320	4820	3490	5160
	6.3	1.6	3800	5200	3970	5540
		2.5	3950	5470	4120	5810
	<b>4 passes through tubes</b>					
	1.6	1.6	2460	3750	2610	4050
	2.5	1.6	2590	3830	2740	4160
		2.5	2740	4150	2890	4450
	4.0	1.6	3060	4340	3210	4640
		2.5	3290	4700	3440	5000
	6.3	1.6	3770	5090	3920	5390
		2.5	3920	5360	4070	5660
	<b>6 passes through tubes</b>					
	1.6	1.6	2470	3710	2600	3980
	2.5	1.6	2600	3790	2740	4100
		2.5	2750	4110	2890	4390
	4.0	1.6	3070	4300	3210	4580
		2.5	3300	4660	3440	4940
	6.3	1.6	3790	5060	3930	5330
		2.5	3940	5330	4080	5600



Shell inner diameter, Di, mm	Pressure PN, MPa		Weight, kg			
			For 25x2 tubes of length		For 25x2.5 tubes of length	
	in tubes	in shell	3000	6000	3000	6000
800	<b>2 passes through tubes</b>					
	1.6	1.6	4050	6400	4380	7060
	2.5	1.6	4430	6830	4760	7490
		2.5	4770	7360	5100	8010
	4.0	1.6	5170	7500	5500	8160
		2.5	5540	8090	5860	8750
	6.3	1.6	6660	8990	6990	9650
		2.5	7010	9590	7340	10250
	<b>4 passes through tubes</b>					
	1.6	1.6	3990	6200	4290	6800
	2.5	1.6	4370	6640	4670	7240
		2.5	4710	7170	5010	7760
	4.0	1.6	5120	7320	5420	7920
		2.5	5490	7910	5780	8510
	6.3	1.6	6610	8810	6910	9410
		2.5	6960	9410	7260	10010
	<b>6 passes through tubes</b>					
	1.6	1.6	4030	6190	4310	6770
	2.5	1.6	4420	6630	4710	7210
		2.5	4760	7160	5050	7730
	4.0	1.6	5180	7320	5460	7900
		2.5	5550	7910	5820	8490
	6.3	1.6	6670	8820	6960	9390
		2.5	7020	9420	7310	9990



Shell inner diameter, Di, mm	Pressure PN, MPa		Weight, kg			
			For 25x2 tubes of length		For 25x2.5 tubes of length	
	in tubes	in shell	3000	6000	3000	6000
1000	<b>2 passes through tubes</b>					
	1.6	1.6	6510	10260	7040	11320
	2.5	1.6	7040	10800	7570	11860
		2.5	7590	11700	8120	12760
	4.0	1.6	8280	12050	8810	13110
		2.5	8830	12920	9360	13990
	6.3	1.6	11030	14800	11560	15850
		2.5	11550	15660	12100	16720
	<b>4 passes through tubes</b>					
	1.6	1.6	6460	10040	6950	11030
	2.5	1.6	6990	10590	7490	11580
		2.5	7540	11490	8040	12480
	4.0	1.6	8250	11860	8740	12840
		2.5	8800	12730	9290	13720
	6.3	1.6	11020	14630	11510	15600
		2.5	11540	15490	12050	16470
	<b>6 passes through tubes</b>					
	1.6	1.6	6500	10050	6700	11000
	2.5	1.6	7070	10600	7550	11560
		2.5	7620	11500	8100	12460
	4.0	1.6	8340	11880	8820	12840
		2.5	8890	12750	9370	13720
	6.3	1.6	11130	14680	11610	15620
		2.5	11650	15540	12150	16490



Shell inner diameter, Di, mm	Pressure PN, MPa		Weight, kg			
			For 25x2 tubes of length		For 25x2.5 tubes of length	
	in tubes	in shell	3000	6000	3000	6000
1200	<b>2 passes through tubes</b>					
	1.6	1.6	9360	14700	10150	16290
	2.5	1.6	10180	15530	10980	17120
		2.5	10810	16450	11600	18040
	4.0	1.6	12310	17660	13100	19250
		2.5	13080	18660	13870	20250
	6.3	1.6	15640	21000	16430	22590
		2.5	16310	21870	17100	23460
	<b>4 passes through tubes</b>					
	1.6	1.6	9320	14450	10060	15940
	2.5	1.6	10150	15290	10910	16790
		2.5	10780	16210	11520	17710
	4.0	1.6	12310	17450	13050	18940
		2.5	13080	18450	13820	19940
	6.3	1.6	15670	20820	16410	22320
		2.5	16340	21690	17080	23190
	<b>6 passes through tubes</b>					
	1.6	1.6	9450	14500	10180	15960
	2.5	1.6	10300	15360	11030	16820
		2.5	10930	16280	11650	17740
	4.0	1.6	12480	17540	13200	19000
		2.5	13250	18540	13970	20000
	6.3	1.6	15870	20940	16590	22400
		2.5	16540	21810	17260	23270

**Note:**

1. Weight of IPT vaporizers is calculated for nominal thickness of sheet metal net of weight of fittings and components.
2. Allowance from weight value must not exceed +8%.
3. For IPT vaporizers Ø25x2 mm tubes are made of high alloy steels, Ø25x2.5 mm tubes are made of carbonic steels.



# Order Form for Vaporizer Manufacturing as to Specifications TU 3612-005-00220802-98

1.	<b>Designation</b> _____		
2.	<b>Design and operating conditions</b> <b>Medium parameter</b>	in tubes	in shell
2.1.	Pressure, MPa P working		
	P design		
2.2.	Working temperature, °C inlet		
	outlet		
2.3.	Temperature of shell walls and tubes, °C <i>(fill in only for INT IKT vaporizers)</i>		
2.4.	Design temperature, °C		
2.5.	Minimum allowed (negative) temperature of heat exchanger wall under pressure, °C		
2.6.	Average air temperature of the coldest five days at heat exchanger layout (site), °C, <i>(fill for heat exchangers to be installed outdoors or in unheated rooms)</i>		
2.7.	Temperature of working medium boiling at pressure 0.07 MPa, °C		
2.8.	Working medium designation and percentage composition		
2.9.	Physical state of medium (gas, vapor, liquid)		
2.10.	Medium characteristics: harmfulness as to standard GOST 12.1.007 <i>(indicating the hazard class)</i>		
	flammability as to standard GOST 12.1.004 "yes", "no"		
	explosive hazard as to standard GOST R 5133.11. 19 <i>(indicating mixture category and group)</i>		
	Does medium cause stress corrosion cracking "yes", "no"		
3.	<b>Gasket material</b>		
4.	Necessity of installation of parts for thermal insulation fixing "yes", "no" <i>(delete as applicable)</i> <i>(parts are installed for heat exchangers with shell diameter 500 mm)</i>		
5.	Necessaty of ICC testing of base metal and welded joints "yes", "no", if "yes" specify procedure as to standard GOST 6032 <i>(fill for heat exchangers where steel grade 08X18H10T, 12X18H10T, 10X17H13M2T, 08X22H6T is applied)</i>		





# **Steam-Water and Water-to-Water Heaters for Heat Supply Networks**

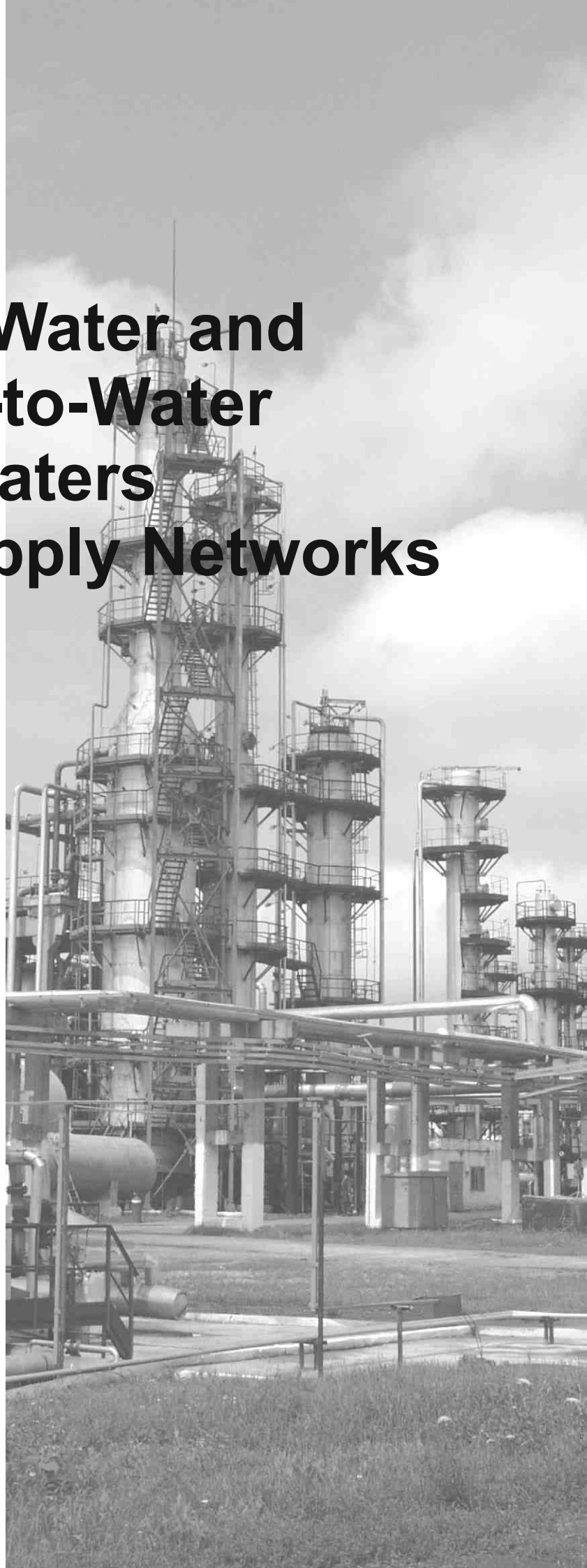



Steam-water and water-to-water heaters are applied to heat water in heating and hot water supply of residential, public and industrial buildings.

Heaters are manufactured in climatic design for operation in temperate regions (U) placement category (indoors placement) as to Standard GOST 15150-69.

Heaters are designed to be installed in regions of seismicity up to 7 points according to 12-point scale adopted in the Russian Federation.

Technical requirements to materials, manufacture, acceptance, testing methods and preservation of apparatuses per SOU MPP 71.120-217:2009, GOST R 52630 and Technical Regulation of Customs Union 032/2013.

The example of heater description when ordering:

Steam-water heater (PP), with 630 mm shell diameter, 3 m heat transferring tubes, 2 passes through tube side, with parts for thermal insulation fixing.

#### Heater 630 PP-3-2 I

**Specifications TU 3113-028-00220302-01**

Water-to-water heater with fixed tube sheets (PVN), with 168 mm shell diameter, 4 m heat transferring tubes, single-stage.

#### Heater 168 PVN-4-1

**Specifications TU 3113-028-00220302-01**

Water-to-water heater with expansion joint on shell (PVK), 273 mm shell diameter, 2 m heat transferring tubes, quantity of heater stages - 4.

#### Heater 273 PVK-2-4

**Specifications TU 3113-028-00220302-01**

Steam-water heaters (PP) can be operated at heat-transfer medium temperature from 0°C up to 300°C, water-to-water heaters - from 0°C up to 200°C.

In design water-to-water heaters are divided into heaters with fixed tube sheets (PVN), with expansion joint on shell (PVK).

### Drawing (sketch) requirements

Drawing (sketch) is made in the case of construction features.

Drawing (sketch) should include:

- sketch of heater is made of full thin lines, with main overall and connection dimensions;
- layout of nozzles, manhole, supports, slinging device (for heaters of types 2 and 3), pads for servicing platform (in the case of placement deviation from figures as to the catalogue);
- nozzles changed as to nominal bore, additional nozzles and pads should be made of full main lines;

- table of nozzles with nozzles designation, nominal bore and nominal pressure;
- technical requirements.

Technical requirements should contain description of heater in accordance with Specifications TU catalogue, list of design differences, necessity of heat treatment for media that cause corrosion cracking, title block in accordance with standard GOST 2.104.

Drawing (sketch) designation, heater designation as to process scheme and heater weight are indicated in the title block.

### Materials for heaters manufacturing

shell, chamber	steel Ст3 сн GOST 380-88
flanges	steel 20 GOST 1050-88
tube sheets	steel 16ГС GOST 5520-79
Ø20x2 mm heat transferring tubes	latten ЛАМШ 70-1 GOST 21646-76

(it is allowed to use tubes made of steels 10, 20 GOST 1050, GOST 550, GOST 8733, gr.B by agreement with the customer).

Heaters are supplied with counter flanges, gaskets and fasteners.

All materials applied for heater manufacturing should be certified.



# 169 Steam-Water Single-Stage Heater

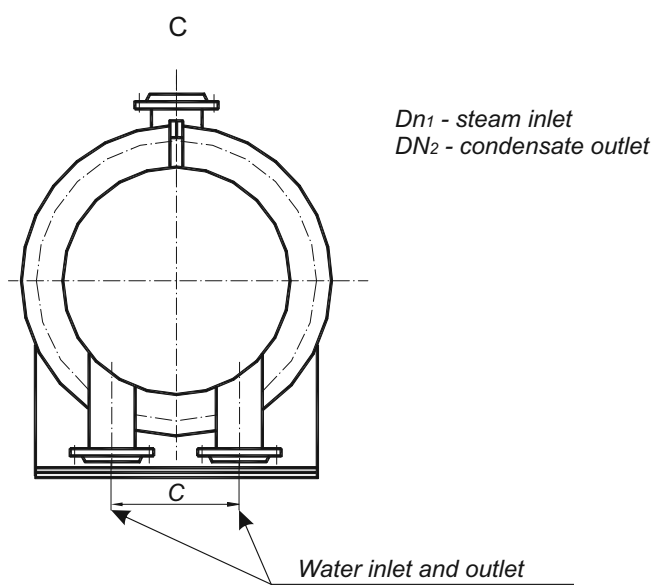
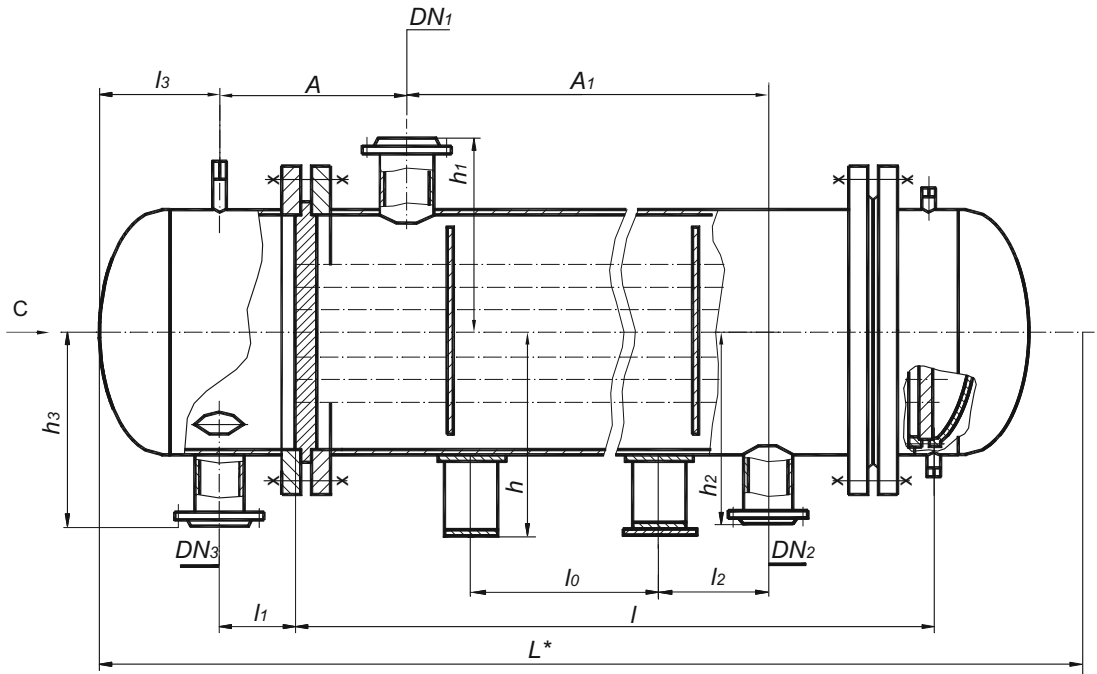

Basic dimensions of steam-water heaters

Shell diameter, mm		Quantity of passes through tubes	Dimensions, mm															Heat exchange surface $m^2 \pm 2\%$
			outer	inner	$L \pm 10$	$l_0 \pm 10$	$l_1 \pm 3$	$l_2 \pm 5$	$l_3 \pm 3$	$h \pm 5$	$h_1 \pm 5$	$h_2 \pm 5$	$h_3 \pm 5$	$DN_1$	$DN_2$	$DN_3$	C	
325	-	2	2820	1100	222	300	250	290	293	293	340	100	50	100	556	1300	8.7	
		2	3820	2000												2300	13.1	
		4	3820	2000												2300	11.3	
426	-	2	2910	1100	256	250	351	413	413	348	370	150	50	125	562	1300	16.1	
		2	3910	2000		300	298			385				100	2300	24.1		
		4	3910	2000		300	285			385				100	2300	21.8		
480	-	2	3025	1000	315	250	426	440	440	375	417	150	50	150	605	1300	23.3	
		2	4025	2000		300	325			405				150	2300	35.0		
		4	4000	2000		300	300							100	2300	32.4		
530	500	2	3065	1000	330	250	471	477	477	420	440	200	80	200	607	1300	29.6	
		2	4035	2000		300	336			415				150	2300	44.4		
		4	4020	2000		300	324			415				125	2300	41.4		
630	600	2	3060	1000	296	250	525	526	526	500	516	250	80	200	665	1300	45.2	
		2	4060	2000		300	442			516				200	2300	67.8		
		4	4030	2000		300	415			480				150	2300	64.0		
720	700	2	3165	950	328	250	570	530	530	556	560	300	125	250	745	1100	61.2	
		2	4165	1900		300	442			560				250	2100	91.9		
		4	4140	1900		300	415			555				200	2100	87.7		
820	800	2	3305	850	402	492	612	620	620	600	605	350	125	300	800	1100	82.8	
		2	4285	1800	402	300	467			600				250	2100	124.3		
		4	4260	1800	408	450	450			600				200	2100	119.0		



# 171 Heat Exchange Surface of Heaters

Heat exchange surface of steam-water heaters

Shell diameter, mm		Tubes assortment, mm	Length of heat transferring tubes, mm	Quantity of passes through tubes	Heat exchange surface m <sup>2</sup> ±2%	Quantity of heat transferring tubes
outer	inner					
325	-	20x2	2000	2	8.7	70
			3000	2	13.1	70
			3000	4	11.3	60
426	-		2000	2	16.1	128
			3000	2	24.1	128
			3000	4	21.8	116
480	-		2000	2	23.3	186
			3000	2	35.0	186
			3000	4	32.4	172
530	500		2000	2	29.6	236
			3000	2	44.4	236
			3000	4	41.4	220
630	600	2000	2	45.2	360	
		3000	2	67.8	360	
		3000	4	64.0	340	
720	700	2000	2	61.2	488	
		3000	2	91.9	488	
		3000	4	87.7	466	
820	800	2000	2	82.8	660	
		3000	2	124.3	660	
		3000	4	119.0	632	

Weight of steam-water heaters

Shell diameter, mm		Length of heat transferring tubes, mm	Quantity of passes through tubes	
			2	4
outer	inner		Weight, kg	
325	-	2000	675	-
		3000	800	775
426	-	2000	935	-
		3000	1110	1070
480	-	2000	1175	-
		3000	1410	1360
530	500	2000	1555	-
		3000	1845	1790
630	600	2000	2000	-
		3000	2480	2420
720	700	2000	2700	-
		3000	3310	3230
820	800	2000	3360	-
		3000	4125	4030



# 172 Layout of Foundation Bolts Holes in Supports

For shells of 325-720 mm diameter

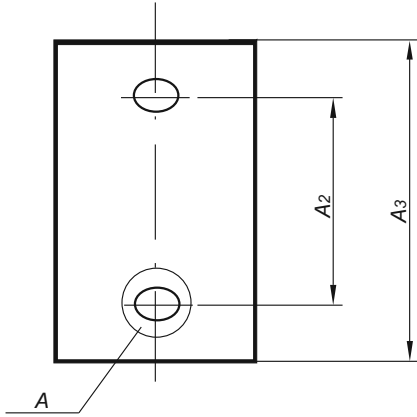

For shells of 800 mm

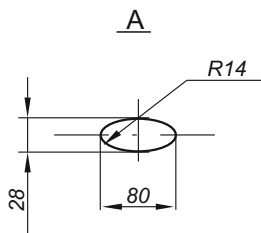
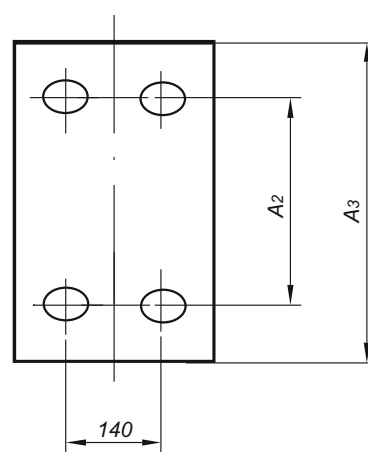

Supports for steam-water heaters must correspond to the diameter specified in the table

Dimensions, mm

Shell diameter, mm		A2	A3
outer	inner		
325	-	330	400
426	-		450
480	-	350	470
530	500	380	500
630	600	450	600
720	700	470	670
820	800	500	740

Limit working pressure for steam-water heaters

Nominal Pressure, PN, MPa	Limit working pressure MPa, at medium temperature, °C max			
	до 100	200	250	300
1.6	1.60	1.49	1.40	1.20



# 173 Water-to-Water Single-Stage Heater

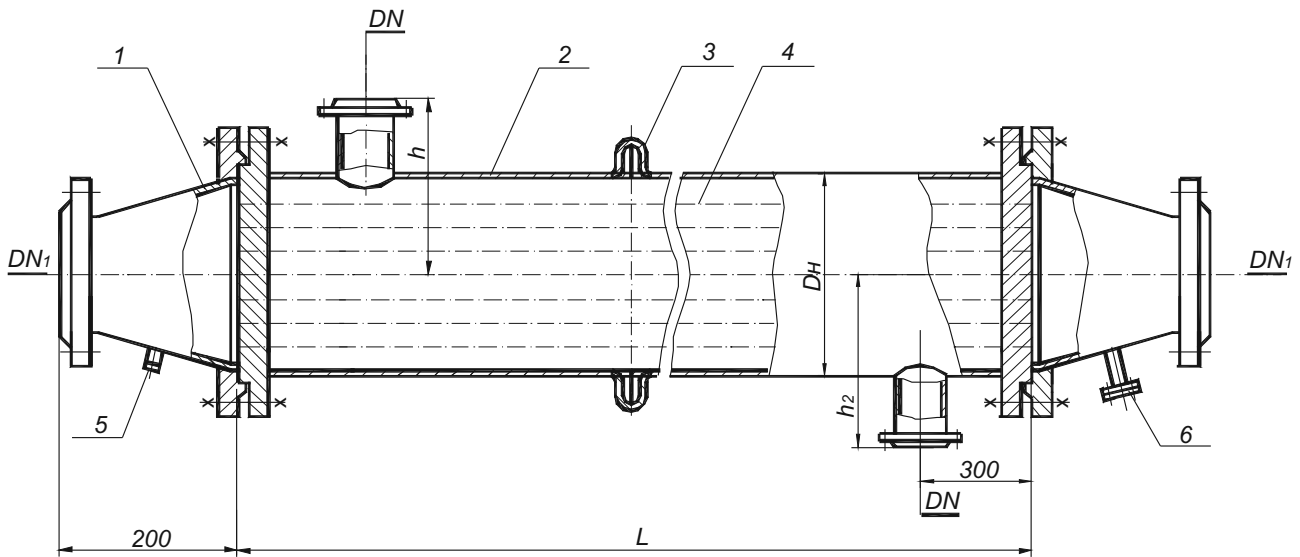

1- chamber, 2 - shell, 3 - expansion joint, 4 - heat transferring tube,  
 5 - boss assembly DN 10 mm for temperature regulator,  
 6 - discharge nozzle DN 20 mm

DN - Inlet (outlet) of heating water  
 DN<sub>1</sub> - Inlet (outlet) of heated water

**Basic dimensions (mm) of water-to-water heaters**

Dimensions, mm

Shell outer diameter, mm	<i>L</i>	<i>L</i> <sub>1±10</sub>	<i>l</i> <sub>±5</sub>	<i>H</i>	<i>h</i> <sub>±5</sub>	<i>DN</i>	<i>DN</i> <sub>1</sub>
76	2000 4000	2300 4300	200	200	100	50	50
114	2000 4000	2424 4424		300	150	80	80
168	2000 4000	2724 4724		400	200	125	125
219	2000 4000	2832 4832		500	250	150	150
273	2000 4000	3038 5038		600	300	200	200
325	2000 4000	3232 5232		700	350	250	250



# 174 Water-to-Water Multi-Stage Heater

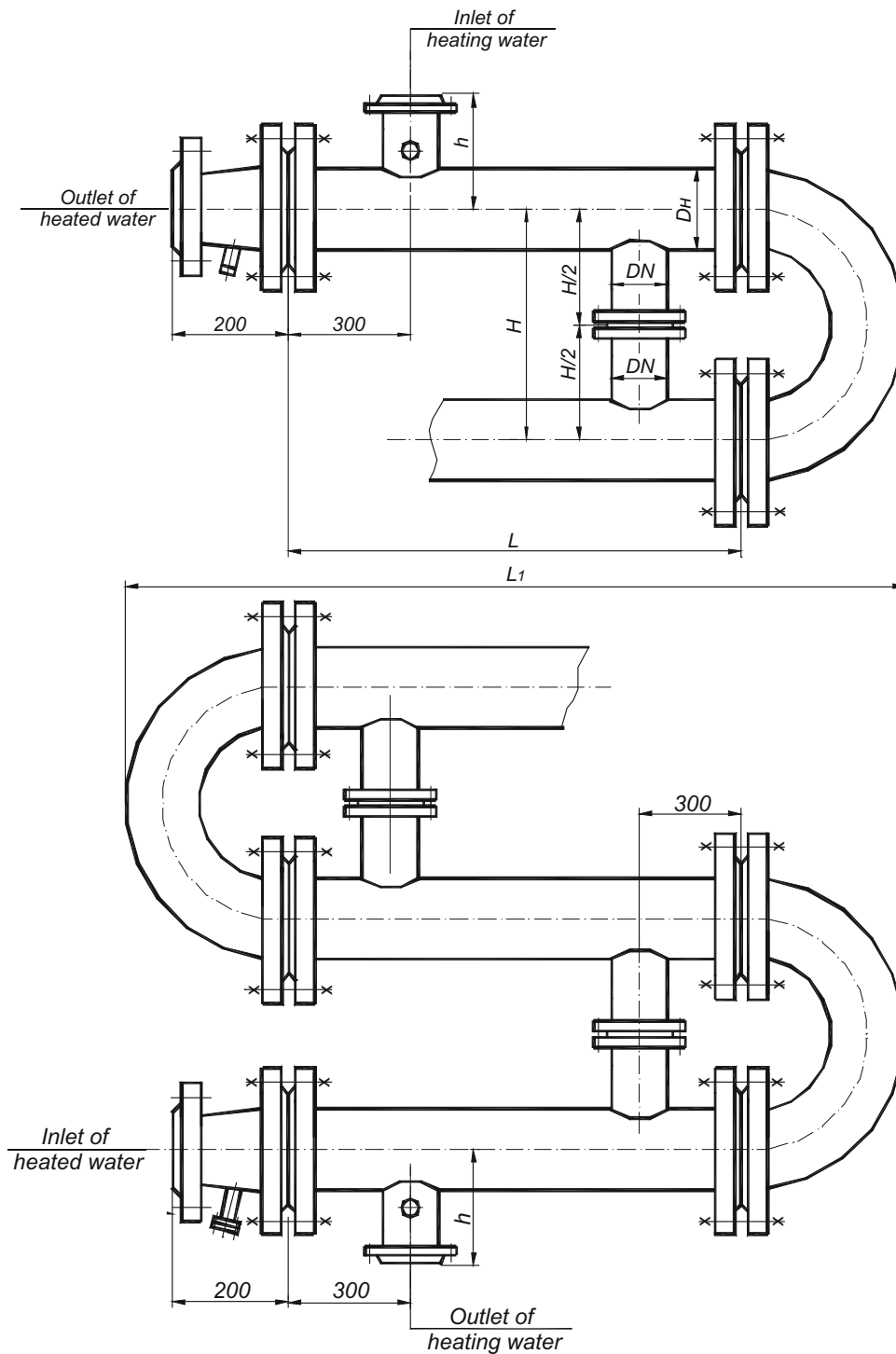

## 175 Heat Exchange Surface of Water-to-Water Heaters

Shell outer diameter, mm	Length of heat transferring tubes, mm	Heat exchange surface m <sup>2</sup> ±2%	Quantity of heat transferring tubes
76	2000	0.5	4
	4000	1.0	
114	2000	1.0	8
	4000	2.0	
168	2000	2.7	22
	4000	5.5	
219	2000	5.2	42
	4000	10.5	
273	2000	8.0	64
	4000	16.0	
325	2000	12.0	96
	4000	24.1	

### Weight of water-to-water heaters

Shell outer diameter, mm	Length of heat transferring tubes, m	Weight, kg
		stage
76	2000	32.5
	4000	53.6
114	2000	56.5
	4000	95.0
168	2000	116.9
	4000	202.2
219	2000	193.7
	4000	342.0
273	2000	283.7
	4000	506.3
325	2000	402.7
	4000	723.3

### Limit working pressure for water-to-water heaters

Nominal Pressure, PN, MPa	Limit working pressure MPa, at medium temperature, °C max	
	до 100	200
1.0	1.00	0.93





### **Certificates of Conformity:**

- ISO 9001:2008 Quality Management Certificate;
- OHSAS 18001-2007 Occupational Health and Safety Management Certificate;
- ISO 14001-2004 Environmental Management System Certificate.
- Certificates of Compliance with the requirements of ASME standards:
  - Manufacture Approval Certificate.

