

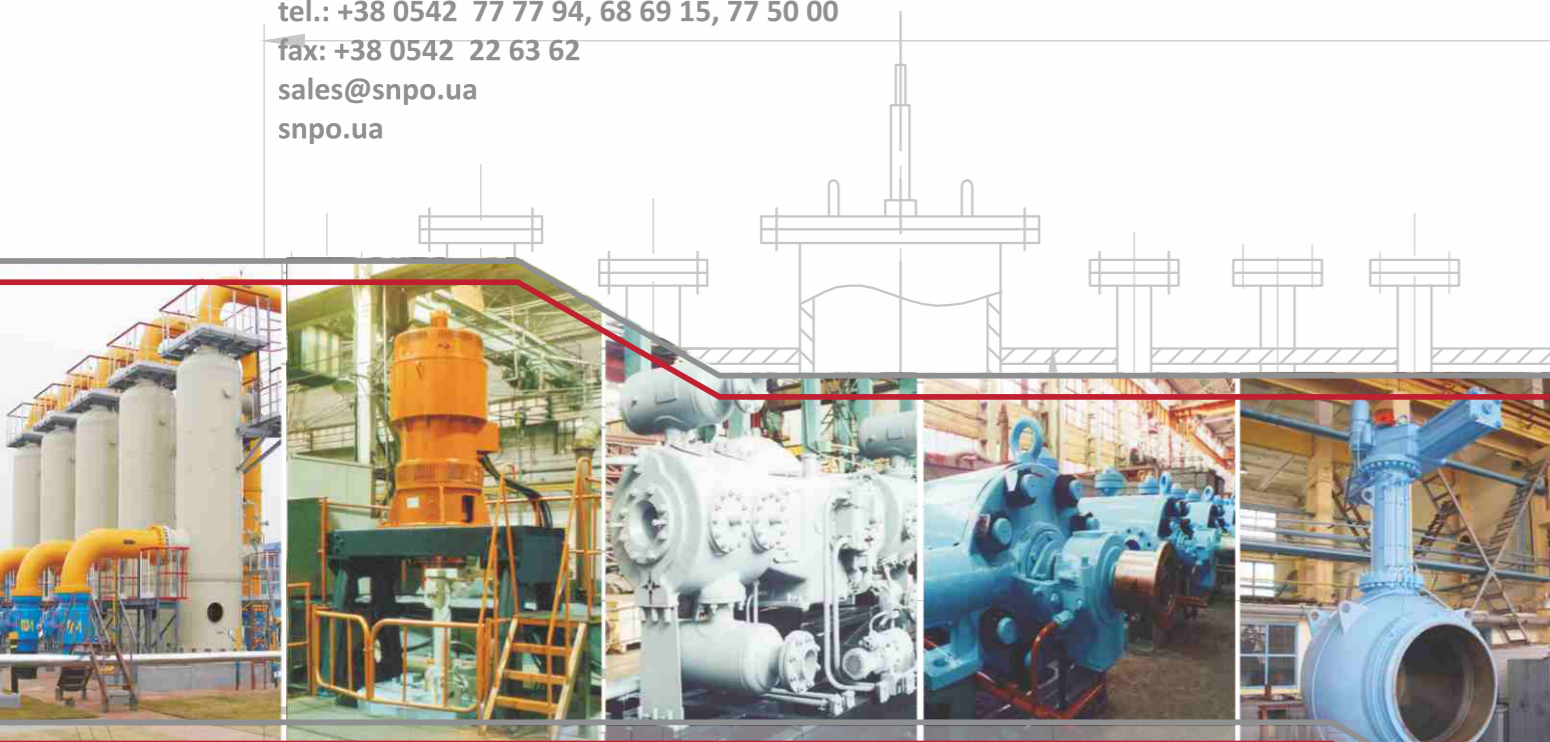

58 Gorkogo Str., Sumy, 40004, Ukraine  
tel.: +38 0542 77 77 94, 68 69 15, 77 50 00  
fax: +38 0542 22 63 62  
sales@snpo.ua  
snpo.ua



TANKS AND PRESSURE VESSELS

*Technical Catalogue*

# TANKS AND PRESSURE VESSELS

“Sumy NPO” PJSC

Representation office in Kiev:  
tel./fax: +38 044 280 98 19, 280 98 28  
frunze-kiev@ukr.net

Branch office in Turkmenistan (Ashgabat):  
tel./fax: +993 12 36 24 81  
frunzeturkm@mail.ru  
frunzeturkm@rambler.ru

Branch office in the Republic of Azerbaijan (Baku):  
tel./fax: +994 12 447 45 68, 497 12 48  
frunze@azeurotel.com

Representation office in the Russian Federation (Moscow):  
tel.: +7 495 664 21 73  
fax: +7 495 745 88 31  
a.efremov@frunze.msk.ru

snpo.ua

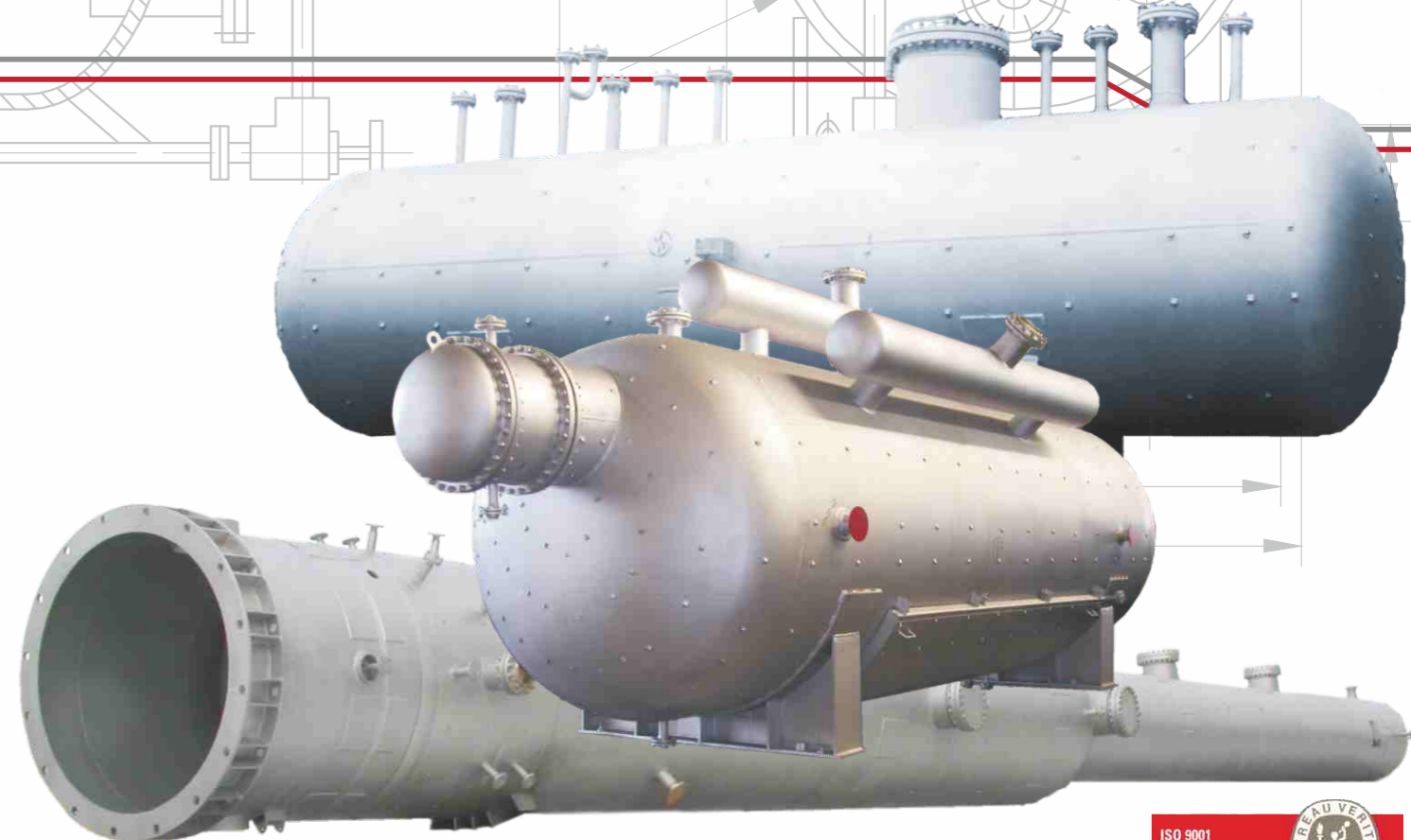

“Sumy NPO” PJSC, founded in 1896, is among eastern Europe's largest machine-building enterprises focused on manufacturing of equipment and providing integral solutions for oil, gas, chemical, petrochemical and power industries.

Product list of the company includes but is not limited to unique types of compressor equipment, pumps, centrifuges, gas ball valves, tanks, pressure vessels, mass- and heat exchangers as well as packaged facilities, namely: gas treatment units (drying, H<sub>2</sub>S removal, fractioning etc), compressor stations, fuel gas skids and other products individually designed, fabricated and tested according to specific project requirements.

Products diversity owes to company's advanced engineering and manufacturing capabilities. Facilities incorporate dedicated yards equipped with the most advanced equipment and cutting edge quality control facilities. Testing facilities comply with the strictest requirements to materials testing, product performance, acceptance and full scale tests of the manufactured products.

High quality of the products is ensured by means of quality assurance and control system that fully complies with international standard ISO 9001. All products comply with the requirements of domestic and international standards.

Products and solutions for chemical, petrochemical oil & gas industry is one of the key expertise of “Sumy NPO” PJSC .

Equipment produced by the company operates at almost all chemical plants in CIS countries.

The Company has supplied pressure vessels and columns to all existing soda mills in CIS and major eastern Europe mills:

- Bereznikovskiy, Lisichanskiy, Sterlitamaskiy, Slavyanskiy, Crimean soda mills, Solvay soda mill (Italy), Soda Sanayi (Turkey), Solvay Sodi mill in Bulgaria, etc.

Chemical equipment is being successfully operated by the following Clients:

- Azot PO (Dneprodzerzhinsk, Cherkassy, Severodonetsk, Nevinnomyssk, Kuibyshev, Rossosh, Mary, Novomoskovsk, etc.)
- chemical mills, oil refining, food and other industries, such as Sumy Khimprom, JSC Navoyi Azot Berezniki Azot, Tambov PA Pigment, Sterlitamak PA Soda, Achinskiy Aluminu, plant, Arkhangelsk pulp-Paper mill, Kotlas PPM, etc.

Significant revamping projects have been executed as a part of after sales service:

- JSC NAFTA and LLC Polimir (Belarus),
- JSC Surgutneftegas, LLC Kirishinefteorgsintez (Russia),
- JSC Concern Stiroil and PA Maryazot (Turkmenistan), etc.



## 2 Table of Contents

---

<b>1. Steel welded vessels</b>	<b>4</b>
Introductory part	5
Designations	5
General information	5
Conditions for calculation	6
Horizontal all-welded vessels with elliptic bottom head	8
Horizontal all-welded vessels with elliptic bottom head, with tube bundle	15
Vertical all-welded vessels with elliptic bottom head	18
Vertical all-welded vessels with elliptic bottom head, with jacket	27
Vertical vessels with elliptic bottom head and cover	30
Vertical vessels with elliptic bottom head and cover, with jacket	33
Vertical all-welded vessels with lower conical (90°) beaded and upper elliptic bottom heads	36
Vertical all-welded vessels with conical (90°) beaded bottom head and elliptic cover, with jacket	41
Vertical аппараты with conical (90°) beaded bottom head and elliptic cover	44
Vertical аппараты with conical (90°) beaded bottom head and elliptic cover, with jacket	47
Horizontal all-welded vessels with spherical unbeaded bottom heads	50
Vertical all-welded vessels with lower conical (90°) unbeaded and upper flat (spherical) bottom heads	53
Vertical all-welded vessels with lower conical (90°) unbeaded and upper flat (spherical) bottom heads, with coil	56
Vertical all-welded vessels with flat bottom heads	59
Vertical all-welded vessels with flat bottom heads, with coil	61
Data sheet for vessel order	63
<b>2. Vertical steel welded vessels with agitators</b>	<b>64</b>
Introductory part	65
General information	65
Vessels with elliptic bottom heads and detachable elliptic cover	73
Vessels with elliptic bottom heads and detachable elliptic cover, with smooth welded jacket	76
All-welded vessels with elliptic bottom head and cover	79
All-welded vessels with elliptic bottom head and cover, with smooth welded jacket	82
All-welded vessels with elliptic bottom head and cover, with half piped jacket	85
Vessels with with flat bottom head and flat detachable cover	87
All-welded vessels with flat bottom head and cover	89
Data sheet for order of vessel with agitator	92
Data sheet for order of mechanical seal for complete vessel with agitator	94
<b>3. Oil, oil product and water storage tanks</b>	<b>95</b>



<b>4. Horizontal underground drain vessels</b>	<b>98</b>
Underground vessels (EP), underground vessels with heater (EPP)	102
Underground vessels (EP), underground vessels with heater (EPP) subject to heat treatment	103
Vessel equipping with concrete pit	104
<b>5. Air collectors-receivers for air stationary compressors</b>	<b>105</b>
<b>6. Liquid strainers for pipelines</b>	<b>112</b>
<b>7. Gas and oil separators</b>	<b>116</b>
<b>8. Multicyclone separators</b>	<b>126</b>
<b>9. Columns</b>	<b>133</b>
Stripping column	135
Absorbing column	136
Variable-diameter rectifying column	137
Rectifying column	138
Adsorber	139
Carbonating column	140
Ø2800 mm absorbing column	141
Distillation column	142
Jib crane	143
Data sheet for column order	144
<b>Certificates and permits</b>	<b>146</b>



# Steel Welded Vessels

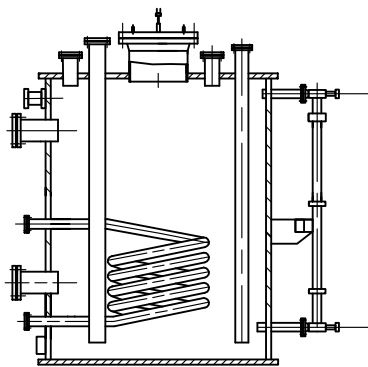
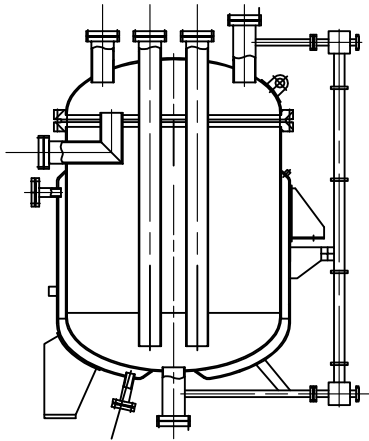
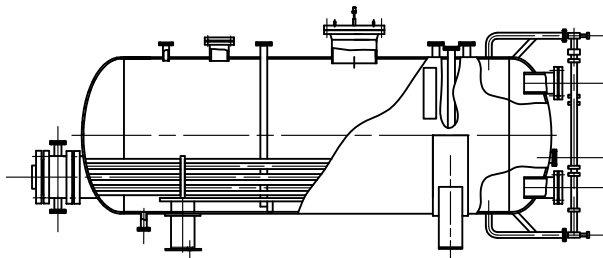

### Introduction

The catalogue includes the following: designation, purpose, scope of application of steel welded vessels, configuration, main parameters, general arrangement drawings with overall dimensions, connection dimensions and mounting dimensions.

The vessels described in the catalogue are not designed for:

- Operation as underground tanks;
- Transportation of working media (for operation on mobile facilities);
- Lining, rubberizing and application of different coatings except for painting.

All vessels are properly sized for railway transportation according to Ministry of Railways of CIS countries.

### Vessels designations

Vessel designation consists of letters and digits.

Letter designation corresponds to the code number of vessel shell type, as per GOST 9931 "Cylindrical shells of steel welded vessels".

For example, GEE1-2-50-0,6: horizontal vessel, with elliptical heads, all-welded, with tube bundle, nominal volume 50 m<sup>3</sup>, nominal pressure 0.6 MPa (6 kgf/cm<sup>2</sup>).

The first letters stands for the following: Г - horizontal or B - vertical; the second and the third letters stand for the type of head: Э - elliptical, К - conical, С - spherical, П - flat (the second letter in designation of vertical vessels means the lower head, and the third head - upper); digits after the letters mean availability or absence of split: 1 – all-welded (without split); 2 – split type; the digit after the first hyphen means availability of internals and heating; 1 – without jacket and internals; 2 - with tube bundle; 3 – with jacket; 4 – with coil; the digit after the second hyphen - nominal volume (m<sup>3</sup>); the last digit - nominal pressure (MPa).

### General information

Technical requirements to materials, manufacture, acceptance, testing methods and preservation of vessels per COY МПП 71.120-217:2009, GOST R 52630 and Technical Regulation of Customs Union 032/2013.

The vessels described in the catalogue are manufactured both with and without heat treatment.

The change in vessel design (nozzles location, their nominal diameters, etc.) is allowed in case these changes are specified in data sheet.

The possibility to change the vessel in specific operation conditions (temperature, corrosion, etc.), as well as possibility to apply packing material, valves, instrumentation, etc. shall be specified by design organization that applies the vessel in its development works.

The following shall be considered when determining the possibility of vessel application:

- The vessels can operate with operating medium with density not higher than allowable one; weight of the vessel in operating condition shall not exceed allowable one (the values of allowable density and weight of vessel in operating condition are given in corresponding tables of catalogue);

- The values of allowable pressures on horizontal vessels outside are defined at design density of operating medium 1600 kg/m<sup>3</sup>; if the density is different from the specified one, the values of allowable pressures, if necessary, shall be specified by design organization that applies the vessel in its development works;

- The vessels described in the catalogue, except for the vertical vessels with upper flat heads, can operate with any operating medium; vertical vessels with flat heads can operate with operating medium (substances) with designations НГ (non-flammable), ТГ (hardly combustible), ГВ (flammable substance), ГЖ (flammable fluid) (as per GOST 12.1.004) and of 3rd, 4th hazard class (as per GOST 12.1.007);

- Possibility to operate vessels in areas with seismic intensity 7 and higher shall be specified by design organization that applies the vessel in its development works, design for earthquake or with explanation that such calculation is not necessary. Design for earthquake shall be performed based on the specific operation conditions of the vessel. By this, rated earthquake force shall be determined as per GOST 24756 or SNiP M-7-81. If calculation results allow operation of vessel in areas with seismic intensity 7 and higher or with explanation that such calculation is not necessary, the following shall be written in column 12 of data sheet: "Possibility of operation is confirmed";

- Vessels with conical beaded heads can be applied in technically justified cases (in other cases vessels with elliptical heads shall be applied).

Possibility to apply vessels in operation conditions different from design conditions and allowable conditions shall be specified by design organization that applies the vessel in its development works, according to the sources given in catalogue. By this, the following shall be specified in corresponding columns of data sheet (where data are exceeded): "Possibility of operation is confirmed".



### Calculation conditions

The vessels given in the catalogue are calculated according to GOST R 52857, GOST 14249 and GOST 24755.

During the calculation the following has been taken: density of operating medium - 1600 kg/m<sup>3</sup>; welding factor -1; coolant density (for vessels with jackets) - 1200 kg/m<sup>3</sup>; heat insulation depth - 60 mm; heat insulation density - 400 kg/m<sup>3</sup>; corrosion allowance from the side of operating medium - 2 mm.

Grades of steels applied for manufacture of vessel shells, with a breakdown by groups, considering the strength characteristics and corrosion resistance and temperature limits for vessel application, depending on the material design of vessel shell, are given in table 1.

Availability factor for corrosion-resistant steels is given in Appendix 2.

Steel grade is selected by design organization that applies the vessel in its development works, based on the effective technical standard documentation and specific operation conditions of vessel.

Vessel jackets are made of steel Ст3сп5 as per GOST 380 (for code of vessel material design 1) or of steel 09Г2С as per GOST 5520 (for code of vessel material design 2, 3 and 4).

At Manufacturer's discretion solid-cast steel grades can be changed. Steel Ст3сп5 (GOST 380) can be changed with steel with another deoxidation degree and of another category and steel 20K (GOST 5520); steel 09Г2С (GOST 5520) can be changed with steel 09Г2С as per GOST 19282 provided that such change is consistent with effective technical standard documentation and operation conditions.

Steel welded vessels are cylindrical vessels with shell sizes as per GOST 9931, with process nozzles for instrumentation connection.

### Grades of steels used for the vessel shells fabrication

Table 1.1

Material make code	Steel grade	Operating wall temperature, °C	
		minimum	maximum
1	Ст3сп5 (GOST 380)	-20	300**
2	09Г2С* (GOST 5520)	-60	
3	08X18H10T 12X18H10T 10X17H13M2T 10X17H13M3T (GOST 5632)	-70	
4	08X22H6T 08X21H6M2T (GOST 5632)	-40	

\* - In special cases maximum temperature can differ from the specified one.

\*\* - Steel category shall be selected subject to the operation conditions.



## Nozzles specification

Table 1.2

Designation	Function	Counterpart	Installation conditions
A	Manhole	-	Permanent for vessels of all types except split-type
Б	Medium inlet (filling)	Flange	Permanent
B	Medium outlet (discharge)		
Г	Medium overflow		
Д	Calm down pipe		
E	Installation of safety valve	Plug	Upon customer request (specified in data sheet)
Ж	Pressure gauge installation		
И	Installation of pipe-type level indicator	Flange	
К	Installation of level gage of UB type (buoyancy)	Plug	
Л	Exposure of thermometer		
M	Reserve		
H	Coolant inlet	Flange	Permanent for vessels with heat exchanging units
П	Coolant outlet		
P	Tube bundle installation	-	Permanent for vessels with tube bundle
У	Air inlet and outlet (in jacket)	Bolt M10 in boss	Permanent for vessels with jackets

## Nominal diameters of nozzles

Table 1.3

Nominal volume, m <sup>3</sup>	A	Б	B, B <sub>1</sub> , B <sub>2</sub>		Г	Д	E	Ж	И <sub>1-2</sub>	К	Л	M, M <sub>1</sub>	M <sub>2</sub>	H <sub>1-2</sub>	П	P	У		
			of vertical vessels	of horizontal vessels															
1	400	50	80	-	-	80	50	50	-	-	-	-	-	-	-	-	-	-	
2																			
3.2																			
5	500	80	150	150	50	150	80	50	20	50	50	50	150	50	50	50	50	6	
6.3																			
10		100	250	250	-	250	150	100	50	-	-	-	-	-	-	-	-	-	
16																			
25		150	200	-	300	100	300	200	100	-	-	-	-	-	-	-	-	-	-
40																			
50																			
63																			
80																			
100																			





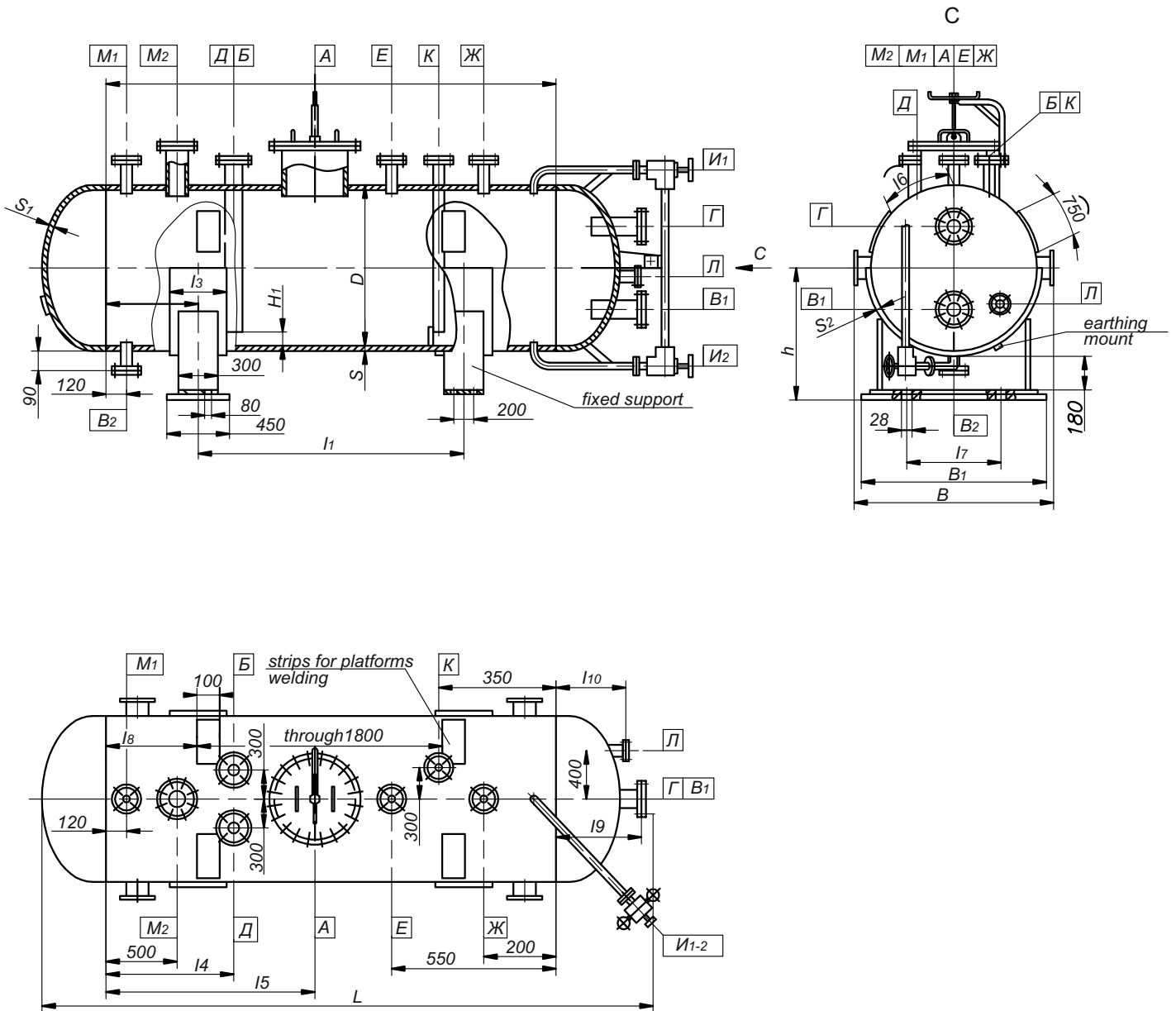

Fig. 1.1

## Horizontal All-Welded Vessels with Elliptic Bottom Head

Main dimensions and weights of vessels

Table 1.4

Designation	Volume, m <sup>3</sup>		D	l	l <sub>1</sub>	l <sub>2</sub>	l <sub>3</sub>	l <sub>4</sub>	l <sub>5</sub>	l <sub>6</sub>	l <sub>7</sub>	l <sub>8</sub>	l <sub>9</sub>	l <sub>10</sub>
	nominal	operating												
GEE1-1-6.3-0.6	6.3	5.4	1600	2500	1600	450	400	800	1400	400	1100	300	530	460
GEE1-1-6.3-1.0														490
GEE1-1-6.3-1.6														
GEE1-1-10-0.6	10	9.1	2000	2500	1600	450	450	800	1400	480	1500	300	590	525
GEE1-1-10-1.0													560	
GEE1-1-10-1.6													610	
GEE1-1-16-0.6	16	13.7	2000	4200	3200	500	450	800	1400	480	1500	250	590	525
GEE1-1-16-1.0													560	
GEE1-1-16-1.6													610	
GEE1-1-25-0.6	25	20.9	2400	4500	3500	500	450	800	1400	480	1800	400	735	605
GEE1-1-25-1.0														640
GEE1-1-25-1.6														
GEE1-1-40-0.6	40	34.3	2400	8000	7000	500	450	800	1400	480	1800	350	735	605
GEE1-1-40-1.0														640
GEE1-1-40-1.6														
GEE1-1-50-0.6	50	42	2800	7000	5800	600	450	1000	1600	520	2200	750	830	660
GEE1-1-50-1.0													710	
GEE1-1-50-1.6													850	
GEE1-1-63-0.6	63	52.4	2800	9000	7800	600	450	1000	1600	520	2200	850	830	660
GEE1-1-63-1.0													710	
GEE1-1-63-1.6													850	
GEE1-1-80-0.6	80	67.4	3000	10000	8700	650	450	1000	1600	520	2200	450	860	740
GEE1-1-80-1.0													880	
GEE1-1-80-1.6														
GEE1-1-100-0.6	100	85.4	3000	13000	11700	650	450	1000	1600	520	2200	150	860	740
GEE1-1-100-1.0													880	
GEE1-1-100-1.6														

Development of design documentation and manufacture of vessels operating under pressure above 1.6 MPa are carried out individually, according to the data sheet sent to our address by the Customer.



Table 1.4 (cont.)

Designation	Material make code	S *	S <sub>1</sub> *	S <sub>2</sub> *	h	L	B	H	Weight, kg			Allowable medium density, kg/m <sup>3</sup>	Maximum operating temperature, °C			
									Stainless steel parts	Total with supports	Vessel operation weight					
GEE1-1-6.3-0.6	1	8	8	6	1018	3530	1770	2455	-	1850	15300	2000	300			
	2							2175	1580	1840						
	3															
	4															
GEE1-1-6.3-1.0	2	10	10	8	1022	3535	1780	2455	-	1980	16000	2000	300			
	3							2485	1705	1975						
	4													1605	1875	
	2															
GEE1-1-6.3-1.6	2	12	14	6	1022	3535	1780	2460	-	2605	16000	2000	300			
	3							2490	2320	2590						
	4													1945	2215	
	2															
GEE1-1-10-0.6	1	8	10	6	1220	3690	2170	2870	-	2565	24100	2000	300			
	2							2585	2210	2540						
	3															
	4															
GEE1-1-10-1.0	2	10	12	8	1225	3695	2185	2780	-	2910	24200	2000	300			
	3							2900	2695	3045						
	4													2250	2600	
	2															
GEE1-1-10-1.6	2	12	16	6	1225	3740	2190	2870	-	3630	25500	2000	300			
	3							2905	3535	3885						
	4													2905	3255	
	2															
ГЭЭ1-1-16-0.6	1	8	10	6	1220	5390	2180	2870	-	3275	37500	1970	300			
	2							2585	2915	3255						
	3													3250		
	4															
GEE1-1-16-1.0	2	10	12	8	1225	5395	2185	2870	-	3775	38800	2000	300			
	3							2900	3570	3920						
	4													2945	3295	
	2															
GEE1-1-16-1.6	2	12	16	6	1225	5440	2190	2870	-	4675	40000	2000	300			
	3							2905	4755	5105						
	4													3950	4300	
	2															
GEE1-1-25-0.6	2	8	10	8	1425	5935	2580	3280	-	4420	47800	1690	300			
	3							2995	3920	4410						
	4													3910	4400	
	2															
GEE1-1-25-1.0	2	10	12	6	1428	5955	2585	3280	-	5220	57000	2000	300			
	3							3315	5290	5800						
	4													3310	4440	4950
	2															
GEE1-1-25-1.6	2	14	18	8	1428	5975	2620	3285	-	7015	59500	2000	300			
	3							3320	7060	7570						
	4													5520	6030	
	2															
GEE1-1-40-0.6	2	8	10	8	1425	9435	2600	3280	-	6155	75400	1650	300			
	3							2995	5645	6145						
	4													5630	6130	
	2															
GEE1-1-40-1.0	2	10	12	6	1428	9455	2610	3280	-	7365	80000**	1720**	300			
	3							3315	7855	8365						
	4													3310	6575	7085
	2															
GEE1-1-40-1.6	2	14	18	8	1428	9475	2620	3285	-	9995	80000**	1660**	300			
	3							3320	10485	10995						
	4													8090	8600	
	2															



# Horizontal All-Welded Vessels with Elliptic Bottom Head

Table 1.4 (cont.)

Designation	Material make code	S *	S <sub>1</sub> *	S <sub>2</sub> *	h	L	B	H	Weight, kg			Allowable medium density, kg/m <sup>3</sup>	Maximum operating temperature, °C
									Stainless steel parts	Total with supports	Vessel operation weight		
GEE1-1-50-0.6	1	10	12	6	1628	8655	3010	3690	-	8320	90700	1600	250
	2							8310	109500	1980	300		
	3							8305	106100	1910			
	4							8295	111700				
GEE1-1-50-1.0	2	12	14	8	1632	10665	3010	3690	-	9705		113500	2000
	3							3720	8875	9710			
	4	10	12	1628	3715			7510	8345				
GEE1-1-50-1.6	2	18	20	6	1635	8670	3035	3695	-	13555	119000	2000	300
	3		22		8710	3725		13045	13880				
	4	14	16	1632	8665	3025	3720	10110	10945				
GEE1-1-63-0.6	1	10	12	6	1628	10665	3010	3690	-	9750	112400	1600	250
	2							9740	131600	1910			
	3							8910	9730	127900	1850		
	4							8900	9720	137200			
GEE1-1-63-1.0	2	12	14	8	1632	10665	3020	3690	-	11435	141000	2000	300
	3							3720	10595	11440			
	4	10	12	1628	3015			3715	8940	9785			
GEE1-1-63-1.6	2	18	20	6	1635	10670	3035	3695	-	16135	147000	2000	300
	3		22		10710	3725		15625	16470				
	4	14	16	1632	10665	3025	3720	12110	12955				
GEE1-1-80-0.6	2	10	12	10	1732	11735	3205	3885	-	11455	140500	1600	250
	3							3595	10545	11450	172000	2000	300
	4												
GEE1-1-80-1.0	2	14	14	14	1740	11735	3220	3895	-	15040	178000	2000	300
	3		16		11740			3925	14430	15345			
	4	10	12	1732	3915			10590	11505	171300	1990		
GEE1-1-80-1.6	2	18	22	8	1740	11790	3235	3895	-	19350	180000	2000	300
	3		20		11790			3235	19890	20805	180000**	1980**	
	4	16	18	12	11745			3230	3925	16185	17100	178000	
GEE1-1-100-0.6	1	12	12	8	1732	14735	3220	3885	-	15650	180000**	1600**	300
	2							3595	14730	15695		1620**	
	3								12820	13725			
	4							10					
GEE1-1-100-1.0	2	14	14	14	1740	14735	3225	3895	-	18365	221800	2000	300
	3		16		14740			3925	17630	18695	222200		
	4	10	12	1732	14735			3220	3915	12875	13790	180000	
GEE1-1-100-1.6	2	18	22	8	1740	14790	3245	3895	-	23625	227100	2000	300
	3		20		14790			3245	24465	25530	229000		
	4	16	18	12	14745			3240	3925	19840	20905		

\* - To be specified at the detailed engineering stage.

\*\* - Allowable density of operating medium and vessel weight in operating condition are given for vessels mounted onto the steel saddle supports, depending on the allowable load onto support. For vessels mounted onto the concrete supports, Allowable density of operating medium and vessel weight in operating condition can be higher than given ones in accordance with the calculation of shell from supports effect.



Allowable operating pressure inside the vessel and allowable external pressure occurring due to the formation of vacuum in the vessel

Table 1.5

Designation	Material make code	Maximum allowed pressure, MPa (kgf/cm <sup>2</sup> )					
		At wall temperature value, °C					External, at maximum operating temperature
		100	150	200	250	300	
GEE1-1-6.3-0.6	1	0.6 (6)	0.58 (5.8)	0.56 (5.6)	0.54 (5.4)	0.5 (5.0)	0.039 (0.39)
	2					0.52 (5.2)	0.044 (0.44)
	3						
	4						
GEE1-1-6.3-1.0	2	1.0 (10)	0.96 (9.6)	0.92 (9.2)	0.9 (9.0)	0.75 (7.5)	0.039 (0.39)
	3	0.95 (9.5)	0.91 (9.1)	0.87 (8.7)	0.84 (8.4)	0.81 (8.1)	0.044 (0.44)
	4	1.0 (10)	0.96 (9.6)	0.93 (9.3)	0.9 (9.0)	0.86 (8.6)	0.045 (0.45)
GEE1-1-6.3-1.6	2	1.6 (16)	1.55 (15.5)	1.5 (15)	1.4 (14)	1.2 (12)	0.099 (0.99)
	3		1.54 (15.4)	1.49 (14.9)	1.44 (14.4)	1.38 (13.8)	
	4		1.35 (13.5)	1.3 (13)			
GEE1-1-10-0.6	1	0.6 (6)	0.58 (5.8)	0.56 (5.6)	0.54 (5.4)	0.5 (5.0)	0.027 (0.27)
	2					0.52 (5.2)	0.031 (0.31)
	3						
	4						
GEE1-1-10-1.0	2	1.0 (10)	0.96 (9.6)	0.92 (9.2)	0.9 (9.0)	0.75 (7.5)	0.064 (0.64)
	3			0.93 (9.3)	0.86 (8.6)	0.83 (8.3)	0.072 (0.72)
	4			0.86 (8.6)	0.83 (8.3)	0.031 (0.31)	
GEE1-1-10-1.6	2	1.41 (14.1)	1.36 (13.6)	1.3 (13)	1.28 (12.8)	1.18 (11.8)	0.099 (0.99)
	3	1.6 (16)	1.54 (15.4)	1.49 (14.9)	1.44 (14.4)	1.38 (13.8)	
	4		1.36 (13.6)	1.31 (13.1)			
GEE1-1-16-0.6	1	0.6 (6)	0.58 (5.8)	0.56 (5.6)	0.54 (5.4)	0.5 (5.0)	0.015 (0.15)
	2					0.52 (5.2)	0.017 (0.17)
	3						
	4						
GEE1-1-16-1.0	2	1.0 (10)	0.96 (9.6)	0.92 (9.2)	0.9 (9.0)	0.75 (7.5)	0.036 (0.36)
	3			0.93 (9.3)	0.86 (8.6)	0.83 (8.3)	0.041 (0.41)
	4			0.86 (8.6)	0.83 (8.3)	0.017 (0.17)	
GEE1-1-16-1.6	2	1.41 (14.1)	1.36 (13.6)	1.3 (13)	1.28 (12.8)	1.18 (11.8)	0.099 (0.99)
	3	1.6 (16)	1.54 (15.4)	1.49 (14.9)	1.44 (14.4)	1.38 (13.8)	
	4		1.36 (13.6)	1.31 (13.1)	0.078 (0.78)		
GEE1-1-25-0.6	2	0.6 (6.0)	0.58 (5.8)	0.56 (5.6)	0.54 (5.4)	0.5 (5.0)	0.011 (0.11)
	3	0.59 (5.9)	0.57 (5.7)	0.54 (5.4)	0.53 (5.3)	0.52 (5.2)	0.012 (0.12)
	4	0.6 (6.0)	0.58 (5.8)	0.56 (5.6)	0.54 (5.4)		
GEE1-1-25-1.0	2	0.92 (9.2)	0.89 (8.9)	0.85 (8.5)	0.83 (8.3)	0.77 (7.7)	0.027 (0.27)
	3	1 (10)	0.96 (9.6)	0.92 (9.2)	0.89 (8.9)	0.85 (8.5)	0.056 (0.56)
	4			0.93 (9.3)	0.9 (9.0)	0.86 (8.6)	0.029 (2.9)
GEE1-1-25-1.6	2	1.43 (14.3)	1.38 (13.8)	1.32 (13.2)	1.3 (13.0)	1.2 (12.0)	0.086 (0.86)
	3	1.6 (16.0)	1.54 (15.4)	1.49 (14.9)	1.44 (14.4)	1.38 (13.8)	0.099 (0.99)
	4	1.52 (15.2)	1.47 (14.7)	1.42 (14.2)	1.27 (12.7)	1.23 (12.3)	0.058 (0.58)



Table 1.5 (cont.)

Designation	Material make code	Maximum allowed pressure, MPa (kgf/cm <sup>2</sup> )						External, at maximum operating temperature
		At wall temperature value, °C						
		100	150	200	250	300		
GEE1-1-6.3-0.6	1	0.6 (6)	0.58 (5.8)	0.56 (5.6)	0.54 (5.4)	0.5 (5.0)	0.039 (0.39)	
	2					0.52 (5.2)		
	3							
	4							
GEE1-1-6.3-1.0	2	1.0 (10)	0.96 (9.6)	0.92 (9.2)	0.9 (9.0)	0.75 (7.5)	0.039 (0.39)	
	3	0.95 (9.5)	0.91 (9.1)	0.87 (8.7)	0.84 (8.4)	0.81 (8.1)	0.044 (0.44)	
	4	1.0 (10)	0.96 (9.6)	0.93 (9.3)	0.9 (9.0)	0.86 (8.6)	0.045 (0.45)	
GEE1-1-6.3-1.6	2	1.6 (16)	1.55 (15.5)	1.5 (15)	1.4 (14)	1.2 (12)	0.099 (0.99)	
	3		1.54 (15.4)	1.49 (14.9)	1.44 (14.4)	1.38 (13.8)		
	4		1.35 (13.5)		1.3 (13)			
GEE1-1-10-0.6	1	0.6 (6)	0.58 (5.8)	0.56 (5.6)	0.54 (5.4)	0.5 (5.0)	0.027 (0.27)	
	2					0.52 (5.2)		
	3							
	4							
GEE1-1-10-1.0	2	1.0 (10)	0.96 (9.6)	0.92 (9.2)	0.9 (9.0)	0.75 (7.5)	0.064 (0.64)	
	3			0.93 (9.3)		0.86 (8.6)	0.072 (0.72)	
	4			0.86 (8.6)		0.83 (8.3)	0.031 (0.31)	
GEE1-1-10-1.6	2	1.41 (14.1)	1.36 (13.6)	1.3 (13)	1.28 (12.8)	1.18 (11.8)	0.099 (0.99)	
	3		1.6 (16)	1.54 (15.4)	1.49 (14.9)	1.44 (14.4)		1.38 (13.8)
	4					1.36 (13.6)		1.31 (13.1)
GEE1-1-16-0.6	1	0.6 (6)	0.58 (5.8)	0.56 (5.6)	0.54 (5.4)	0.5 (5.0)	0.015 (0.15)	
	2					0.52 (5.2)		
	3							
	4							
GEE1-1-16-1.0	2	1.0 (10)	0.96 (9.6)	0.92 (9.2)	0.9 (9.0)	0.75 (7.5)	0.036 (0.36)	
	3			0.93 (9.3)		0.86 (8.6)	0.041 (0.41)	
	4			0.86 (8.6)		0.83 (8.3)	0.017 (0.17)	
GEE1-1-16-1.6	2	1.41 (14.1)	1.36 (13.6)	1.3 (13)	1.28 (12.8)	1.18 (11.8)	0.099 (0.99)	
	3		1.6 (16)	1.54 (15.4)	1.49 (14.9)	1.44 (14.4)		1.38 (13.8)
	4					1.36 (13.6)		1.31 (13.1)
GEE1-1-25-0.6	2	0.6 (6.0)	0.58 (5.8)	0.56 (5.6)	0.54 (5.4)	0.5 (5.0)	0.011 (0.11)	
	3	0.59 (5.9)	0.57 (5.7)	0.54 (5.4)	0.53 (5.3)		0.012 (0.12)	
	4	0.6 (6.0)	0.58 (5.8)	0.56 (5.6)	0.54 (5.4)			
GEE1-1-25-1.0	2	0.92 (9.2)	0.89 (8.9)	0.85 (8.5)	0.83 (8.3)	0.77 (7.7)	0.027 (0.27)	
	3	1 (10)	0.96 (9.6)	0.92 (9.2)	0.89 (8.9)	0.85 (8.5)	0.056 (0.56)	
	4			0.93 (9.3)	0.9 (9.0)	0.86 (8.6)	0.029 (2.9)	
GEE1-1-25-1.6	2	1.43 (14.3)	1.38 (13.8)	1.32 (13.2)	1.3 (13.0)	1.2 (12.0)	0.086 (0.86)	
	3	1.6 (16.0)	1.54 (15.4)	1.49 (14.9)	1.44 (14.4)	1.38 (13.8)	0.099 (0.99)	
	4	1.52 (15.2)	1.47 (14.7)	1.42 (14.2)	1.27 (12.7)	1.23 (12.3)	0.058 (0.58)	



Table 1.5 (cont.)

Designation	Material make code	Maximum allowed pressure, MPa (kgf/cm <sup>2</sup> )						External, at maximum operating temperature		
		At wall temperature value, °C								
		100	150	200	250	300				
GEE1-1-100-0.6	1	0.6 (6.0)	0.58 (5.8)	0.56 (5.6)	0.54 (5.4)	0.5 (5.0)	0.006 (0.06)			
	2						0.007 (0.07)			
	3						0.008 (0.08)			
	4						0.002 (0.02)			
GEE1-1-100-1.0	2	1.0 (10.0)	0.96 (9.6)	0.93 (9.3)	0.9 (9.0)	0.75 (7.5)	0.016 (0.16)			
	3						0.018 (0.18)			
	4						0.002 (0.02)			
GEE1-1-100-1.6	2	1.6 (16.0)	1.55 (15.5)	1.5 (15.0)	1.4 (14.0)	1.2 (12.0)	0.045 (0.45)			
	3		1.54 (15.4)					1.49 (14.9)	1.44 (14.4)	1.38 (13.8)
	4									

# Horizontal All-Welded Vessels with Elliptic Bottom Head, with Tube Bundle

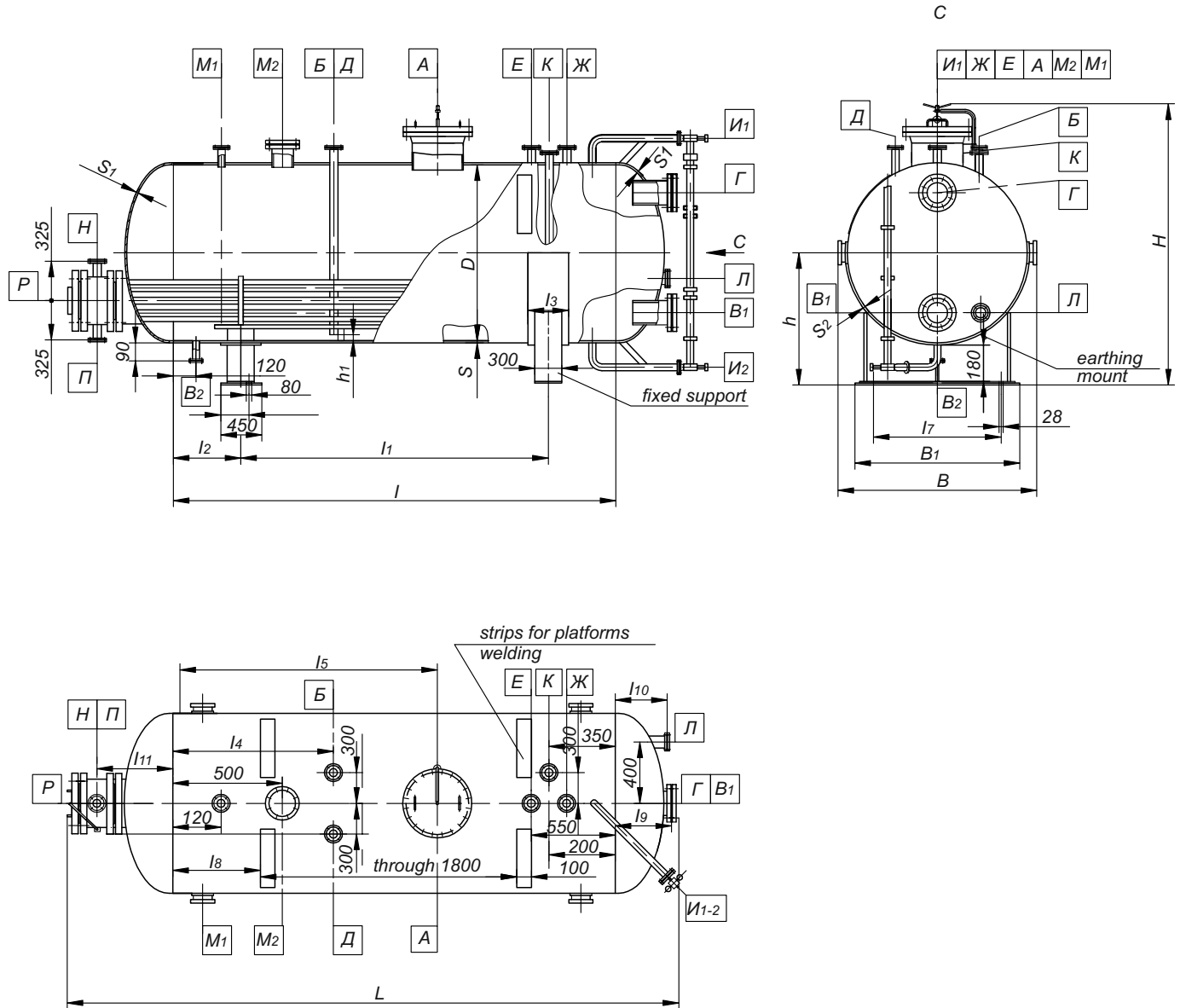

Fig. 1.2

Development of design documentation and manufacture of vessels operating under pressure above 0.6 MPa are carried out individually, according to the data sheet sent to our address by the Customer.





# Horizontal All-Welded Vessels with Elliptic Bottom Head, with Tube Bundle

Main dimensions of vessels, heat exchanging surface area

Table 1.6

Designation	Volume, m <sup>3</sup>		Heat exchange surface area, m <sup>2</sup>	D	l	l <sub>1</sub>	l <sub>2</sub>	l <sub>3</sub>	l <sub>4</sub>	l <sub>5</sub>	l <sub>6</sub>	l <sub>8</sub>	l <sub>9</sub>	l <sub>10</sub>	l <sub>7</sub>	B <sub>1</sub>	h <sub>1</sub>	
	nominal	operating																
GEE1-2-6.3-0.6	6.3	5.4	10.5	1600	2500	1600	450	400	800	1400	400	300	530	590	525	1500	1790	100
GEE1-2-10-0.6	10	9.1		2000														
GEE1-2-16-0.6	16	13.7	18.6	2400	4500	3500	500	450	4800	400	735	605	1800	2140	140			
GEE1-2-25-0.6	25	20.9			8000	7000										600	1000	1600
GEE1-2-40-0.6	40	34.3	31.4	2800	7000	5800	600	1000	1600	520	750	830	660	2200	2480			
GEE1-2-50-0.6	50	42			9000	7800										600	1000	1600
GEE1-2-63-0.6	63	52.4	35.2	2800	9000	7800	600	1000	1600	520	850	830	660	2200	2480			

Main dimensions and weights of vessels

Table 1.7

Designation	Material make code	h	S*	S <sub>1</sub> *	S <sub>2</sub> *	l <sub>11</sub>	L	B	H	Weight, kg*			Allowable medium density, kg/m <sup>3</sup>	Maximum operating temperature, °C		
										Stainless steel parts	Total with supports	Vessel operation weight				
GEE1-2-6.3-0.6	1	1018	8	8	6	762	4075	1770	2470	-	2310	15300	2000	300		
	2					758	4070		2180	2040	2300					
	3															
	4															
GEE1-2-10-0.6	1	1220	10	10	8	838	4210	2170	2880	-	3025	24100	2000	300		
	2					832	4200		2590	3020	3005					
	3															
	4															
GEE1-2-16-0.6	1	1220	8	10	6	838	5910	2180	2880	-	3910	37500	1970	300		
	2					832	5905		2590	3905	38600					
	3															
	4															
GEE1-2-25-0.6	2	1425	8	10	8	922	6440	2580	3290	-	5090	47800	1690	300		
	3								2995	4590	5080				46300	1630
	4									4575	5065				56000	2000
GEE1-2-40-0.6	2	1425	8	10	8	922	9940	2600	3290	-	7160	75400	1650	300		
	3								2995	6650	7150				73600	1600
	4									6635	7135				80000	1720
GEE1-2-50-0.6	1	1628	10	12	6	998	9115	3010	3700	-	9325	90700	1600	250		
	2					992	9110		3400	9315	109500				1980	
	3															
	4															
GEE1-2-63-0.6	1	1628	10	12	6	998	11115	3010	3690	-	10850	112400	1600	250		
	2					992	11110		3400	10840	131600				1910	
	3															
	4															
GEE1-2-63-0.6	3	1628	10	12	6	992	11110	3010	3400	10010	10830	127900	1850	300		
	4									10000	10820	137200	2000			

\* - Clarified during design engineering.



## Horizontal All-Welded Vessels with Elliptic Bottom Head, with Tube Bundle

Allowable operating pressure inside the vessel and allowable external pressure occurring due to the formation of vacuum in the vessel

Table 1.8

Designation	Material make code	Maximum allowed pressure, MPa (kgf/cm <sup>2</sup> )						
		At wall temperature value, °C					External, at maximum operating temperature	
		100	150	200	250	300		
GEE1-2-6.3-0.6	1	0.6(6)	0.58(5.8)	0.56(5.6)	0.54(5.4)	0.5(5)	0.039(0.39)	
	2					0.52(5.2)		
	3							
	4							
GEE1-2-10-0.6	1	0.6(6)	0.55(5.5)	0.56(5.6)	0.54(5.4)	0.5(5)	0.027(0.27)	
	2					0.52(5.2)		
	3							
	4							
GEE1-2-16-0.6	1	0.6(6)	0.58(5.8)	0.56(5.6)	0.54(5.4)	0.5(5)	0.015(0.15)	
	2					0.52(5.2)		
	3							
	4							
GEE1-2-25-0.6	2	0.6(6)	0.58(5.8)	0.56(5.6)	0.54(5.4)	0.5(5)	0.011(0.11)	
	3					0.52(5.2)	0.012(0.12)	
	4							
GEE1-2-40-0.6	2	0.6(6)	0.58(5.8)	0.56(5.6)	0.54(5.4)	0.5(5)	0.004(0.04)	
	3	0.59(5.9)	0.57(5.7)	0.54(5.4)	0.53(5.3)		0.05(0.05)	
	4	0.6(6)	0.58(5.8)	0.56(5.6)	0.54(5.4)			0.52(5.2)
GEE1-2-50-0.6	1	0.6(6)	0.58(5.8)	0.56(5.6)	0.54(5.4)	-	0.012(0.12)	
	2					0.5(5)		
	3					0.52(5.2)		0.014(0.14)
	4							
GEE1-2-63-0.6	1	0.6(6)	0.58(5.8)	0.56(5.6)	0.54(5.4)	-	0.008(0.08)	
	2					0.5(5)		
	3					0.52(5.2)		0.009(0.09)
	4							



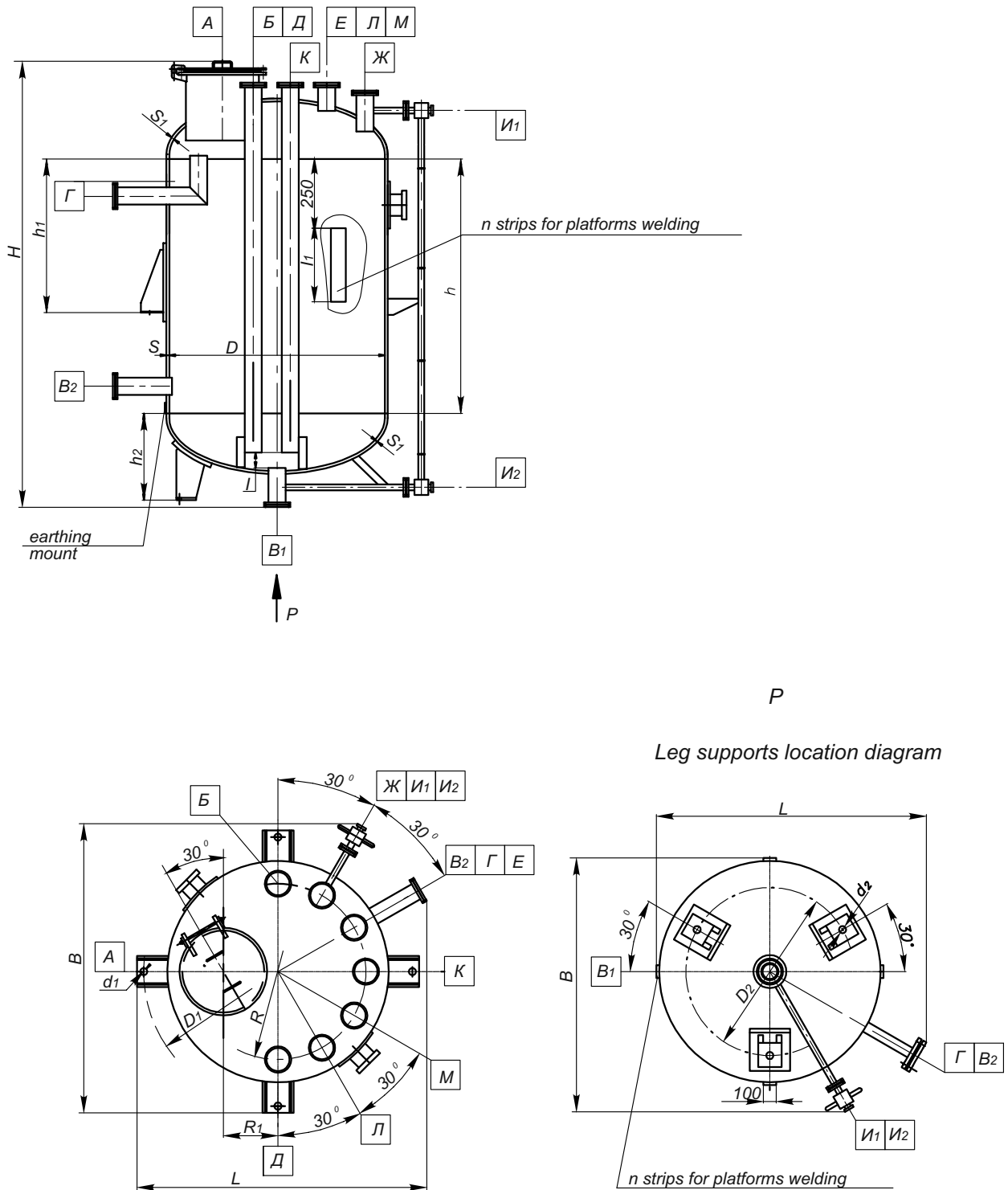

Fig. 1.3



Main dimensions of vessels

Table 1.9

Designation	Volume, m <sup>3</sup>		Nominal pressure, MPA (kgf/cm <sup>2</sup> )	Dimensions, mm						n
	nominal	operating		D	h	R	R <sub>1</sub>	l (max.)	l <sub>1</sub>	
VEE1-1-1-0.6	1	0.91	0.6(6)	1000	900	360	180	100	-	-
VEE1-1-1-1.0			1.0(10)							
VEE1-1-1-1.6			1.6(16)							
VEE1-1-2-0.6	2	1.74	0.6(6)	1200	1250	450	260	185	700	4
VEE1-1-2-1.0			1.0(10)							
VEE1-1-2-1.6			1.6(16)							
VEE1-1-3.2-0.6	3.2	3	0.6(6)	1400	1600	520	340	200	700	4
VEE1-1-3.2-1.0			1.0(10)							
VEE1-1-3.2-1.6			1.6(16)							
VEE1-1-5-0.6	5	4.3	0.6(6)	1600	1800	580	360	250	700	4
VEE1-1-5-1.0			1.0(10)							
VEE1-1-5-1.6			1.6(16)							
VEE1-1-6.3-0.6	6.3	5.6	0.6(6)	1600	2500	580	360	250	700	4
VEE1-1-6.3-1.0			1.0(10)							
VEE1-1-6.3-1.6			1.6(16)							
VEE1-1-10-0.6	10	9.2	0.6(6)	2000	2500	740	520	320	1000	8
VEE1-1-10-1.0			1.0(10)							
VEE1-1-10-1.6			1.6(16)							
VEE1-1-16-0.6	16	15.5	0.6(6)	2000	4500	740	520	320	1000	8
VEE1-1-16-1.0			1.0(10)							
VEE1-1-16-1.6			1.6(16)							
VEE1-1-25-0.6	25	22.9	0.6(6)	2400	4500	860	680	340	1000	8
VEE1-1-25-1.0			1.0(10)							
VEE1-1-25-1.6			1.6(16)							

Development of design documentation and manufacture of vessels operating under pressure above 1.6 MPa are carried out individually, according to the data sheet sent to our address by the Customer.



## Vessel wall thickness

Table 1.10

Designation	Material make code	Dimensions, mm	
		S	S <sub>1</sub>
VEE1-1-1-0.6	1	6	6
	2		
	3		
VEE1-1-1-1.0	2	6	8
	3	8	
	4	6	6
VEE1-1-1-1.6	2	8	10
	3		
	4		
VEE1-1-2-0.6	2	6	6
	3		
	4		
VEE1-1-2-1.0	2	8	8
	3		
	4	6	
VEE1-1-2-1.6	1	10	12
	2		
	3	8	10
	4		
VEE1-1-3-2-0.6	2	6	8
	3		
	4		
VEE1-1-3-2-1.0	2	8	10
	3		8
	4		
VEE1-1-3-2-1.6	2	10	12
	3	12	
	4	10	
VEE1-1-5-0.6	1	8	8
	2		
	3		
	4	6	
VEE1-1-5-1.0	2	10	10
	3		
	4		
VEE1-1-5-1.6	2	12	14
	3		
	4		
VEE1-1-6.3-0.6	1	8	8
	2		
	3		
	4		
VEE1-1-6.3-1.0	2	10	10
	3		
	4		

Table 1.10 (cont.)

Designation	Material make code	Dimensions, mm	
		S	S <sub>1</sub>
VEE1-1-6.3-1.6	2	12	14
	3		
	4	10	12
VEE1-1-10-0.6	2	8	10
	3		
	4		
VEE1-1-10-1.0	2	10	12
	3		10
	4		
VEE1-1-10-1.6	2	14	16
	3		
	4	12	
VEE1-1-16-0.6	1	10	10
	2		
	3		
	4	8	
VEE1-1-16-1.0	2	10	12
	3		10
	4		
VEE1-1-16-1.6	2	14	16
	3		18
	4	12	14
VEE1-1-25-0.6	2	10	10
	3		
	4		
VEE1-1-25-1.0	2	12	14
	3		
	4		
VEE1-1-25-1.6	2	16	20
	3		
	4		



Main dimensions and weights of vessels on lug supports

Table 1.11

Designation	Material make code	Dimensions, mm						Weight, kg			Allowable medium density, kg/m <sup>3</sup>		
		D <sub>1</sub>	h <sub>1</sub>	d <sub>1</sub>	L	B	H	Stainless steel parts	Total	Vessel operation weight (not more)			
VEE1-1-1-0.6	1	1210	350	24	1250	1315	1965	-	440	2630	2000		
	2						1985	415	435				
	3						1970	-	500			2690	
VEE1-1-1-1.0	2	1220	350	24	1260	1320	1990	525	545	2730			
	3						1250	1315	465	2650			
	4						1220	2260	-	620		2790	
VEE1-1-1-1.6	2	1220	350	24	1260	1320	1950	585	605	2790			
	3						580	600					
	4						2370	-	610			4710	
VEE1-1-2-0.6	2	1442	350	24	1535	1540	2390	570	605	4710			
	3						2375	-	760			4860	
	4						1545	1540	2395		645	680	4780
VEE1-1-2-1.0	2	1445	350	24	1535	1545	2695	-		5080			
	3						2385	935	975		4940		
	4						1442	1545	1545		2385	800	835
VEE1-1-2-1.6	1	1455	350	24	1545	1545	2870	-	870	7590	1950		
	2						2885	825	860	6660	1670		
	3						2875	-	1080	7970			
VEE1-1-3.2-0.6	2	1645	350	24	1735	1735	2895	1035	1070	7960	2000		
	3						2895	965	1000	7890			
	4						1648	1745	1745	3165		-	1310
VEE1-1-3.2-1.0	2	1655	350	24	1745	1745	2855	1360	1400	8290			
	3						1755	1755	2855	1235		1270	8160
	4						1655	1745	1745	2855		1235	1270
VEE1-1-3.2-1.6	2	1655	350	24	1745	1745	3445	-	1360	12300		2000	
	3						3155	1280	1340	10050		1610	
	4						1905	1135	1190	10050			
VEE1-1-5-0.6	2	1910	500	35	2000	2000	3445	-	1630	12600		2000	
	3						3475	1555	1380	12300			
	4						1910	2000	2000	3475	1315		1380
VEE1-1-5-1.0	2	1915	500	35	2005	2005	3445	-	2030	13000			
	3						3475	1950	2010	12700			
	4						1910	2005	2005	3475	1690		1750
VEE1-1-5-1.6	2	1925	500	35	2015	2015	4145	-	1590	13900	1900		
	3						3855	1525	1580	14500			
	4						1915	2005	2005	3855	1515		1570
VEE1-1-6.3-0.6	2	1915	500	35	2005	2005	4145	-	1940	14900	2000		
	3						4175	1865	1930	14850			
	4						1910	2000	2000	4175		1555	1620
VEE1-1-6.3-1.0	2	1925	500	35	2015	2015	4145	-	2380	15300			
	3						4175	2295	2360	15100			
	4						1915	2005	2005	4175		2075	2050
VEE1-1-6.3-1.6	2	1925	500	35	2015	2015	4145	-	2380	15300			
	3						4175	2295	2360	15100			
	4						1915	2005	2005	4175		2075	2050



Table 1.11 (cont.)

Designation	Material make code	Dimensions, mm						Weight, kg			Allowable medium density, kg/m <sup>3</sup>			
		D <sub>1</sub>	h <sub>1</sub>	d <sub>1</sub>	L	B	H	Stainless steel parts	Total	Vessel operation weight (not more)				
VEE1-1-10-0.6	2	2370	500	35	2490	2490	4365	-	2230	19300	1600			
	3						4075	2130						
	4							2120				2220	23400	
VEE1-1-10-1.0	2	2375	500	35	2495	2495	4365	-	2690	23900	2000			
	3						4395	2575				2980	22200	
	4							2415				2520	23700	
VEE1-1-10-1.6	2	2390	500	35	2510	2510	4375	-	3590	24800	2000			
	3											3465	3570	24750
	4							2385				2505	2505	3035
VEE1-1-16-0.6	1	2525	750	42	2655	2655	6365	-	3740	37850	2000			
	2						6075	3510				3720		
	3							3050				3260	37350	
VEE1-1-16-1.0	2	2525	750	42	2665	2665	6365	-	3940	38050	2000			
	3	2535					6395	3720		34550	1790			
	4	2525					2655	2655		3560	3780	37900		
VEE1-1-16-1.6	2	2540	750	42	2670	2670	6385	-	5300	39400	2000			
	3						6415	5220				5400	39550	
	4						2535	2665				2665	4410	4630
VEE1-1-25-0.6	2	3090	750	42	3220	3220	6530	-	5220	55350	2000			
	3						6240	46100				5200	51650	1850
	4							4500				5180	55350	2000
VEE1-1-25-1.0	2	3095	750	42	3225	3225	6570	-	6270	56400	2000			
	3						6600	5660				6260		
	4							3220				3220	4890	5490
VEE1-1-25-1.6	2	3110	750	42	3240	3240	6580	-	8170	58300	2000			
	3						6610	7560				8160		
	4						3105	3235				3235	6560	7160

Main dimensions and weights of vessels on lug supports

Table 1.12

Designation	Material make code	Dimensions, mm						Weight, kg			Allowable medium density, kg/m <sup>3</sup>												
		D <sub>2</sub>	h <sub>2</sub>	d <sub>2</sub>	L	B	H	Stainless steel parts	Total	Vessel operation weight													
VEE1-1-1-0.6	1	920	415	19	1140	1200	1965	-	445	2640	2000												
	2						1985	415	440														
	3						1970	-	505														
VEE1-1-1-1.0	2		920		420		19	1145	1200	1990		525	550	2740	2000								
	3									1990		440	465	2650									
	4									2260		-	625	2810									
VEE1-1-1-1.6	2				920			425		19		1145	1200	1950		585	610	2800	2000				
	3													1950		580	605	2790					
	4													2370		-	630	4730					
VEE1-1-2-0.6	2							1100				515		24		1335	1385	2390		580	625	4880	2000
	3																	2375		-	780	4880	
	4																	2395		735	780	4800	
VEE1-1-2-1.0	2	1100		540		24					1350	1390				2715		-		1020	5120	2000	
	3															2405		945		990	5090		
	4															2400		810		850	4950		
VEE1-1-2-1.6	1		1100	535			24		1350		1385				2870	-		890		7480	2000		
	2														2885	835		880		7470			
	3														2875	-		1100		7490			
VEE1-1-3.2-0.6	2			1260	565				24	1520			1570		2895	1050		1020	7480	1910			
	3														2895	975		1020	7480				
	4														3165	-		1330	7490				
VEE1-1-3.2-1.0	2				1260			560		24				1530	1575	3165	-	1330	7490				1850
	3															2855	1370	1420	7480				
	4															2855	1250	1300	7490				
VEE1-1-3.2-1.6	2	1260				570		24				1535		1575		3165	-	1330	7490			1780	
	3															2855	1370	1420	7480				
	4															2855	1250	1300	7490				
VEE1-1-5-0.6	1		1410			660	35				1755	1760				3445	-	1380	1930		11950		
	2															3155	1280	1360	1960				
	3															3155	1130	1210	1960				
VEE1-1-5-1.0	2			1410		665			35		1755		1765			3445	-	1660	1870	11950			
	3															3475	1560	1640	1920				
	4															3475	1320	1400	1920				
VEE1-1-5-1.6	2				1410	660				35	1755				1760	3450	-	2060	1790				11950
	3															3450	1950	2030	1800				
	4															3480	1685	1770	1850				





Table 1.12 (cont.)

Designation	Material make code	Dimensions, mm						Weight, kg			Allowable medium density, kg/m <sup>3</sup>					
		D <sub>2</sub>	h <sub>2</sub>	d <sub>2</sub>	L	B	H	Stainless steel parts	Total	Vessel operation weight (not more)						
VEE1-1-6.3-0.6	1	1410	740	35	1755	1760	4260	-	1670	14600	2000					
	2							1535	1650							
	3						1525	1640								
	4						3965	4160	-			2010				
VEE1-1-6.3-1.0	2		745			1765	1760	1765	4160	-		2010	14950			
	3									1875		2000	14650			
	4				1575					1700		14650				
VEE1-1-6.3-1.6	2		755		1765	1765	1765	426.5	-	2470		15400				
	3								2315	2440		15150				
	4							750	1760	4295		2105	2130	15150		
												2105	2130	15150		
VEE1-1-10-0.6	2		1810		915	42	2130	2125	4455	-		2430	23600	2000		
	3	4160		2195					2410	23550						
	4	4455		-					2890	24050						
VEE1-1-10-1.0	2	955		2135					2130	2130	4515	-	3790		24950	
	3											4485	2620		2720	23900
	4											4485	2450		2720	23900
VEE1-1-10-1.6	2	945		2135	2130		2130	4515	-	3790	24950					
	3								4545	3535	3780	24550				
	4								4535	3125	3370	24550				
VEE1-1-16-0.6	1	1810		1115	42		2130	2125	6655	-	4090	38150	2000			
	2								6365	3570	4080	37700				
	3								6660	-	4280	38350				
	4		6090			3770			4120	38200						
VEE1-1-16-1.0	2		1120	2140		2130			2130	6720	-	5620		39700		
	3										6385	3610		4120	38200	
	4						6755	4480			4980	39100				
VEE1-1-16-1.6	2		1150	2135		2130	2130	6755	-	5090	47850					
	3								6460	4575	5080	47850				
	4								1155	2140	2130	6755		4555	5060	47850
														4555	5060	47850
VEE1-1-25-0.6	2		2210	1135		42	2540	2520	6780	-	6180	48000		1700		
	3	6810			5665				5370	47900						
	4	6805			4855				5370	47900						
VEE1-1-25-1.0	2	1165		2555	2555				2555	6800	-	8060	48400			
	3										6830	7525	8040		48350	
	4										6805	4855	5370		47900	
VEE1-1-25-1.6	2	1170	2550	2520	2520	6820	-	8060	48400							
	3						6830	7525	8040	48350						
	4						6820	6495	6990	47850						



Allowable operating pressure inside the vessel and allowable external pressure occurring due to the formation of vacuum in the vessel

Table 1.13

Designation	Material make code	Maximum allowed pressure, MPa (kgf/cm <sup>2</sup> )					External at wall temperature 300°C	
		At wall temperature value, °C						
		100	150	200	250	300		
VEE1-1-1-0.6	1	0.6(6)	0.58(5.8)	0.56(5.6)	0.54(5.4)	0.5(5)	0.077(0.77)	
	2						0.085(0.85)	
	3						0.077(0.77)	
VEE1-1-1-1.0	2	1(10)	0.96(9.6)	0.93(9.3)	0.9(9)	0.75(7.5)	0.099(0.99)	
	3						0.085(0.85)	
	4						0.099(0.99)	
VEE1-1-1-1.6	2	1.57(15.7)	1.51(15.1)	1.46(14.6)	1.4(14)	1.2(12)	0.099(0.99)	
	3	1.49(14.9)	1.43(14.3)	1.37(13.7)	1.33(13.3)	1.27(12.7)		
	4	0.6(16)	1.54(15.4)	1.49(14.9)	1.44(14.4)	1.38(13.8)		
VEE1-1-2-0.6	2	0.6(6)	0.58(5.8)	0.56(5.6)	0.54(5.4)	0.5(5)	0.043(0.43)	
	3	0.58(5.8)	0.55(5.5)	0.53(5.3)	0.51(5.1)	0.49(4.9)	0.048(0.48)	
	4	0.6(6)	0.58(5.8)	0.54(5.4)	0.54(5.4)	0.52(5.2)		
VEE1-1-2-1.0	2	0.99(9.9)	0.95(9.5)	0.92(9.2)	0.9(9)	0.75(7.5)	0.099(0.99)	
	3	0.94(9.4)	0.9(9)	0.87(8.7)	0.84(8.4)	0.81(8.1)		
	4	1(10)	0.96(9.6)	0.93(9.3)	0.9(9)	0.86(8.6)		
VEE1-1-2-1.6	2	1.6(16)	1.55(15.5)	1.5(15)	1.44(14.4)	1.2(12)	0.099(0.99)	
	3		1.54(15.4)	1.49(14.9)		1.38(13.8)		
	4					1.32(13.2)		
VEE1-1-3.2-0.6	2	0.6(6)	0.58(5.8)	0.56(5.6)	0.54(5.4)	0.5(5)	0.027(2.7)	
	3					0.52(5.2)	0.03(0.3)	
	4							
VEE1-1-3.2-1.0	2	1(10)	0.96(9.6)	0.93(9.3)	0.9(9)	0.75(7.5)	0.078(0.78)	
	3				0.86(8.6)	0.087(0.87)		
	4				0.88(8.8)	0.85(8.5)		
VEE1-1-3.2-1.6	2	1.54(15.4)	1.48(14.8)	1.43(14.3)	1.4(14)	1.2(12)	0.099(0.99)	
	3	1.51(15.1)	1.45(14.5)	1.39(13.9)	1.35(13.5)	1.29(12.9)		
	4	1.6(16)	1.54(15.4)	1.49(14.9)	1.44(14.4)	1.38(13.8)		
VEE1-1-5-0.6	1	0.6(6)	0.58(5.8)	0.56(5.6)	0.53(5.3)	0.5(5)	0.052(0.52)	
	2				0.54(5.4)		0.058(0.58)	
	3						0.52(5.2)	0.02(0.2)
	4							
VEE1-1-5-1.0	2	1(10)	0.96(9.6)	0.93(9.3)	0.9(9)	0.75(7.5)	0.099(0.99)	
	3			0.92(9.2)	0.89(8.9)	0.85(8.5)		
	4			0.92(9.2)	0.89(8.9)	0.86(8.6)		0.77(7.7)
VEE1-1-5-1.6	2	1.6(16)	1.55(15.5)	1.5(15)	1.4(14)	1.2(12)	0.099(0.99)	
	3		1.54(15.4)	1.49(14.9)	1.44(14.4)	1.38(13.8)		
	4				1.4(14)	1.35(13.5)		
VEE1-1-6.3-0.6	1	0.59(5.9)	0.58(5.8)	0.55(5.5)	0.53(5.3)	0.47(4.7)	0.043(0.43)	
	2	0.6(6)		0.56(5.6)	0.54(5.4)	0.5(5)		
	3					0.52(5.2)		0.048(0.48)
	4							
VEE1-1-6.3-1.0	2	1(10)	0.96(9.6)	0.93(9.3)	0.9(9)	0.75(7.5)	0.097(0.97)	
	3	0.99(9.9)	0.95(9.5)	0.91(9.1)	0.88(8.8)	0.84(8.4)	0.099(0.99)	
	4	0.91(9.1)	0.88(8.8)	0.85(8.5)	0.76(7.6)	0.73(7.3)	0.048(0.48)	
VEE1-1-6.3-1.6	2	1.6(16)	1.55(15.5)	1.5(15)	1.44(14.4)	1.2(12)	0.099(0.99)	
	3		1.54(15.4)	1.48(14.8)		1.38(13.8)		
	4			1.49(14.9)				



Table 1.13 (cont.)

Designation	Material make code	Maximum allowed pressure, MPa (kgf/cm <sup>2</sup> )						External at wall temperature 300°C
		At wall temperature value, °C						
		100	150	200	250	300		
VEE1-1-10-0.6	1	0.6(6)	0.58(5.8)	0.56(5.6)	0.54(5.4)	0.46(4.6)	0.03(0.3)	
	2		0.56(5.6)	0.51(5.1)	0.48(4.8)	0.43(4.3)	0.033 (0.33)	
	3		0.58(5.8)	0.56(5.6)	0.54(5.4)	0.52(5.2)		
VEE1-1-10-1.0	2	1(10)	0.96(9.6)	0.93(9.3)	0.9(9)	0.75(7.5)	0.068(0.68)	
	3	0.99(9.9)	0.95(9.5)	0.91(9.1)	0.89(8.9)	0.85(8.5)	0.075(0.75)	
	4	1(10)	0.96(9.6)	0.93(9.3)	0.9(9)	0.86(8.6)		
VEE1-1-10-1.6	2	1.6(16)	1.55(15.5)	1.5 (15)	1.4(14)	1.2(12)	0.099(0.99)	
	3	1.52 (15.2)	1.46(14.6)	1.4(14)	1.36(13.6)	1.3(13)		
	4	1.6(16)	1.54(15.4)	1.49(14.9)	1.44(14.4)	1.36(13.6)		
VEE1-1-16-0.6	1	0.6(6)	0.58 (5.8)	0.56 (5.6)	0.54(5.4)	0.5 (5)	0.04 (0.4)	
	2					0.045(0.45)		
	3						0.02(0.2)	
	4							
VEE1-1-16-1.0	2	1 (10)	0.96(9.6)	0.93(9.3)	0.9(9)	0.75(7.5)	0.04(0.4)	
	3	0.96(9.6)	0.93(9.3)	0.89(8.9)	0.86(8.6)	0.82(8.2)	0.045(0.45)	
	4	1(10)	0.96(9.6)	0.93(9.3)	0.84(8.4)	0.81(8.1)		
VEE1-1-16-1.6	2	1.57(15.7)	1.52(15.2)	1.46(14.6)	1.4(14)	1.2(12)	0.099(0.99)	
	3	1.55(15.5)	1.48(14.8)	1.42(14.2)	1.38(13.8)	1.32(13.2)	0.082(0.82)	
	4	1.6(16)	1.54(15.4)	1.49(14.9)	1.44(14.4)	1.35(13.5)		
VEE1-1-25-0.6	2	0.6(6)	0.58(5.8)	0.56(5.6)	0.54(5.4)	0.5(5)	0.03(0.3)	
	3					0.52(5.2)	0.033(0.33)	
	4							
VEE1-1-25-1.0	2	1(10)	0.96(9.6)	0.93(9.3)	0.9(9)	0.75(7.5)	0.055(0.55)	
	3					0.86(8.6)	0.061(0.61)	
	4						0.033(0.33)	
VEE1-1-25-1.6	2	1.6(16)	1.54(15.4)	1.48(14.8)	1.4(14)	1.2(12)	0.099(0.99)	
	3		1.45(14.5)	1.39(13.9)	1.35(13.5)	1.3(13)		
	4		1.54(15.4)	1.49(14.9)	1.44(14.4)	1.38(13.8)		

# Vertical All-Welded Vessels with Elliptic Heads, with Jacket

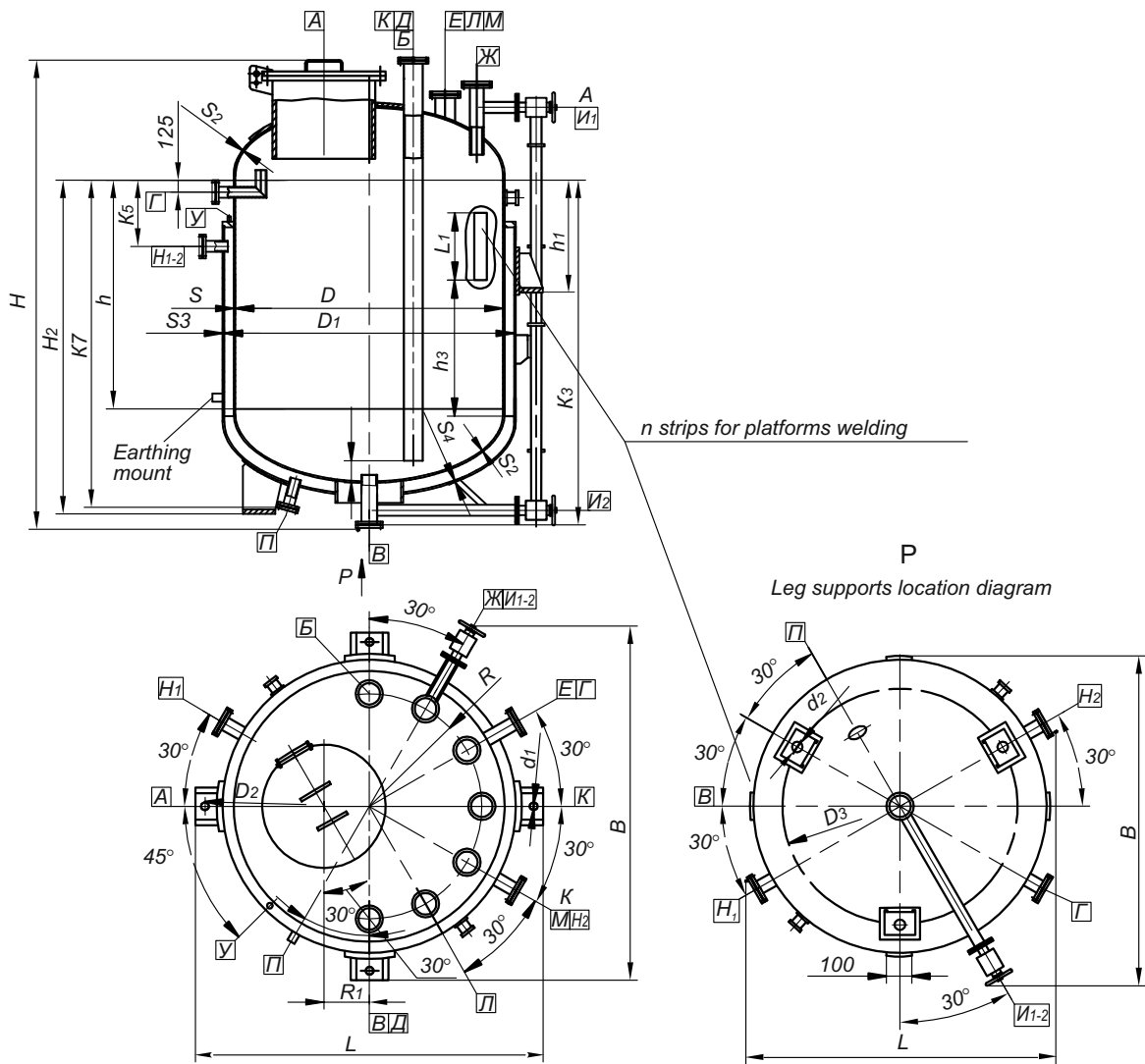

Fig. 1.4

Main dimensions of vessels, heat exchanging surface area

Table 1.14

Designation	Volume, m <sup>3</sup>		Area of the heat exchanging surface, m <sup>2</sup>	D	D <sub>1</sub>	S <sub>2</sub>	S <sub>4</sub>	h	h <sub>3</sub>	R	R <sub>1</sub>	l	l <sub>1</sub>	n
	Nominal	Operating												
VEE1-3-1-1.0	1	0.93	3.6	1000	1100	6	6	900	-	360	180	160	-	-
VEE1-3-2-1.0	2	1.8	4.7	1200	1300	6	8	1250	40	450	260	185	700	4
VEE1-3-3.2-1.0	3.2	3	7.2	1400	1500	6	8	1600	200	520	340	200	700	4
VEE1-3-5-1.0	5	4.4	10.1	1600	1700	8	10	1800	400	580	360	250	700	4
VEE1-3-6.3-1.0	6.3	5.8	13.2	1600	1700	8	10	2500	800	580	360	250	700	4
VEE1-3-10-1.0	10	9.3	17.3	2000	2200	10	12	2500	750	740	520	320	1000	8

Development of design documentation and manufacture of vessels operating under pressure of 0.6 MPa, 1.6 MPa and higher are carried out individually, according to the data sheet sent to our address by the Customer.



## Vertical All-Welded Vessels with Elliptic Heads, with Jacket

Main dimensions of vessels

Table 1.15

Designation	Material make code	Dimensions, mm					
		S	S <sub>1</sub>	S <sub>2</sub>	K <sub>3</sub>	K <sub>6</sub>	K <sub>7</sub>
VEE1-3-1-1.0	1	12	8	12	1335	330	1355
	2						
	3		6				
	4						
VEE1-3-2-1.0	1	12	10	14	1735	585	1770
	2		8				
	3			12			
	4						
VEE1-3-3.2-1.0	1	14	10	14	2195	625	2165
	2						
	3		8				
	4						
VEE1-3-5-1.0	2	16	10	16	2415	515	2410
	3		8				
	4						
VEE1-3-6.3-1.0	2	18	10	16	3115	610	3110
	3	16					
	4						
VEE1-3-10-1.0	2	20	12	20	3295	665	3220
	3	18		18			
	4						

Main dimensions and weights of vessels on lug supports

Table 1.16

Designation	Material make code	Dimensions, mm						Weight, kg			Allowable medium density, kg/m <sup>3</sup>
		D <sub>2</sub>	h <sub>1</sub>	d <sub>1</sub>	L	B	H	Stainless steel parts	Total	Vessel operation weight (not more)	
VEE1-3-1-1.0	1	1315	550	24	1355	1355	1925	-	910	3280	2000
	2						1945	650			
	3							640			
	4										
VEE1-3-2-1.0	1	1545	850	24	1640	1640	2370	-	1320	5680	2000
	2						2355		1290	5650	
	3						2375	930	1280	5640	
	4										
VEE1-3-3.2-1.0	1	1805	1000	35	1900	1900	2860	-	1960	8060	1630
	2	1745		24	1840	1840	2880	1460	1940	9260	2000
	3							1420	1910	9230	
	4										
VEE1-3-5-1.0	2	2000	900	35	2090	2090	3440	-	2980	14650	2000
	3						3470	2140	2990	14700	
	4							2100	2950	14650	
VEE1-3-6.3-1.0	2	2000	1000	35	2090	2090	4145	-	3860	16000	1730
	3						4175	2600	3660	15950	1760
	4							2560	3620	15900	
VEE1-3-10-1.0	2	2570	1150	35	2690	2690	4385	-	5900	25150	1670
	3						4415	3855	5570		1700
	4							3785	5500		1710



## Vertical All-Welded Vessels with Elliptic Heads, with Jacket

Main dimensions and weights of vessels on lug supports

Table 1.17

Designation	Material make code	Dimensions, mm						Weight, kg			Allowable medium density, kg/m <sup>3</sup>
		D <sub>3</sub>	h <sub>2</sub>	D <sub>2</sub>	L	B	H	Stainless steel parts	Total	Vessel operation weight (not more)	
VEE1-3-1-1.0	1	1000	1365	19	1330	1255	1925	-	910	3280	2000
	2						650	920	3290		
	3						640	900	3270		
	4										
VEE1-3-2-1.0	1	1200	1800	24	1505	1445	2390	-	1350	5710	2000
	2						2375	1320	5680		
	3						2395	930	1300	5660	
	4										
VEE1-3-3.2-1.0	1	1360	2260	35	1680	1630	2880	-	1990	9310	2000
	2						2900	1460	2000	9320	
	3						1420	1960	9280		
	4										
VEE1-3-5-1.0	2	1510	2565	35	1850	1800	3545	-	3060	14750	2000
	3						3575	2140	3070		
	4						2100	3030	14700		
VEE1-3-6.3-1.0	2	1510	3265	35	1850	1800	4225	-	3940	17750	2000
	3						4275	2600	3740	17550	
	4						2560	3700	17500		
VEE1-3-10-1.0	2	2010	3455	42	2280	2270	4495	-	6090	28700	2000
	3						4525	3855	5760	28400	
	4						3785	5690	28300		

Allowable operating pressure inside the vessel and allowable external pressure occurring due to the formation of vacuum in the vessel

Table 1.18

Designation	Material make code	Maximum allowed pressure, MPa (kgf/cm <sup>2</sup> )					External at wall temperature 300 °C and pressure in jacket of 0,6 MPa (6 kgf/cm <sup>2</sup> )				
		At wall temperature value, °C									
		100	150	200	250	300					
VEE1-3-1-1.0	1	1(10)	0.96(9.6)	0.93(9.3)	0.9(9)	0.75(7.5)	0.099(0.99)				
	2							0.86(8.6)			
	3										
	4								0.83(8.3)	0.8(8)	
VEE1-3-2-1.0	1	1(10)	0.96(9.6)	0.93(9.3)	0.9(9)	0.75(7.5)	0.003(0.03)				
	2						0.021(0.21)				
	3						0.94(9.4)	0.9(9)	0.87(8.7)	0.83(8.3)	-
	4						0.96(9.6)	0.93(9.3)	0.9(9)	0.86(8.6)	0.005(0.05)
VEE1-3-3.2-1.0	1	1(10)	0.96(9.6)	0.93(9.3)	0.9(9)	0.75(7.5)	0.001(0.01)				
	2						0.027(0.27)				
	3						0.86(8.6)	0.079(0.79)			
	4						0.099(0.99)				
VEE1-3-5-1.0	2	1(10)	0.96(9.6)	0.93(9.3)	0.9(9)	0.75(7.5)	0.099(0.99)				
	3							0.86(8.6)			
	4							0.83(8.3)	0.8(8)		
VEE1-3-6.3-1.0	2	1(10)	0.96(9.6)	0.93(9.3)	0.9(9)	0.75(7.5)	0.099(0.99)				
	3						0.86(8.6)	0.007(0.07)			
	4						0.83(8.3)	0.8(8)	0.017(0.17)		
VEE1-3-10-1.0	2	1(10)	0.96(9.6)	0.93(9.3)	0.9(9)	0.75(7.5)	0.099(0.99)				
	3						0.86(8.6)	-			
	4						0.011(0.11)				



# Vertical All-Welded Vessels with Elliptic Head and Cover

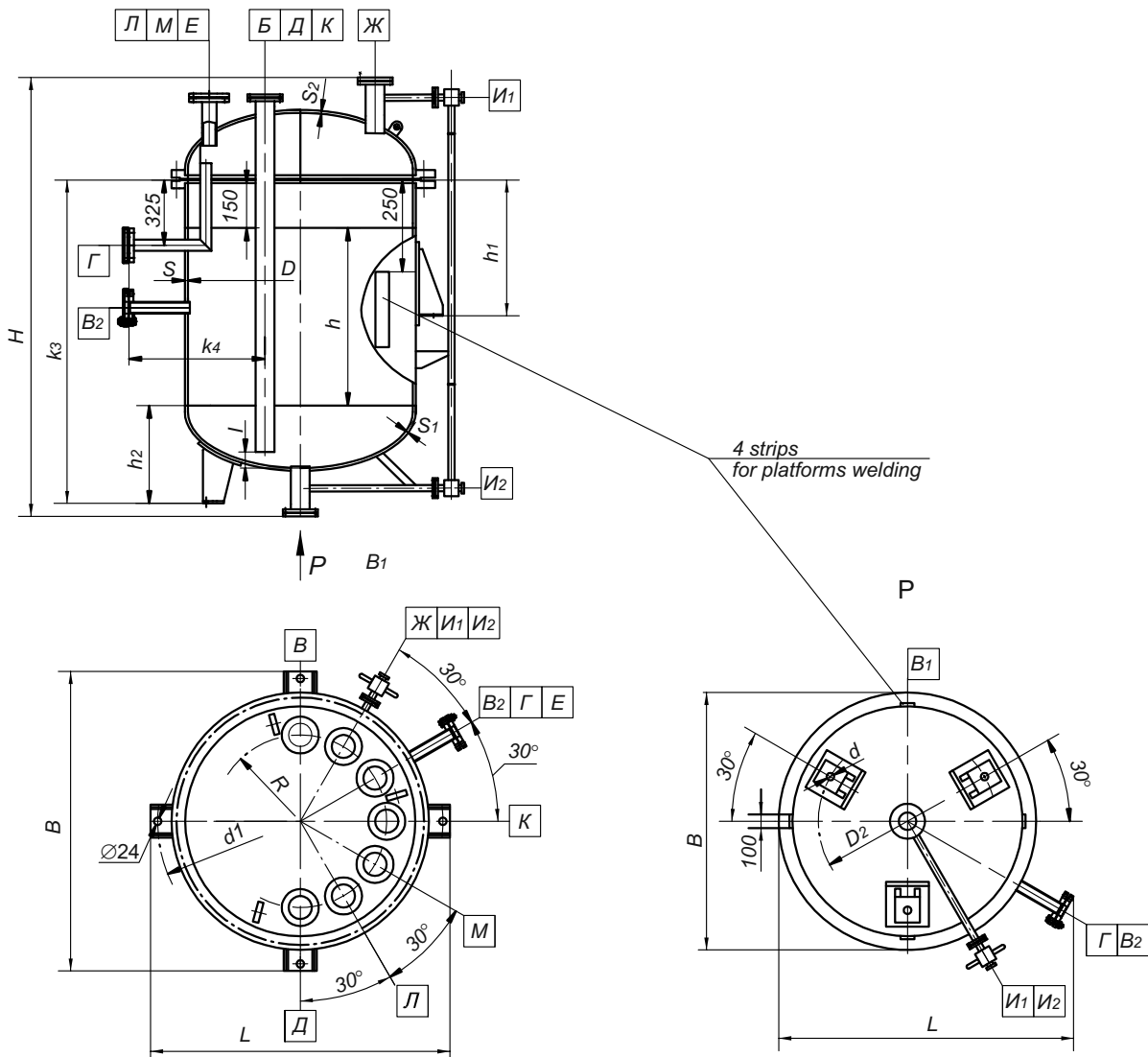

Fig. 1.5

Main dimensions of vessels

Table 1.19

Designation	Volume, m <sup>3</sup>		Nominal pressure, MPa (kgf/cm <sup>2</sup> )	Material make code	Dimensions, mm								
	Nominal	Operating			D	R	S	S <sub>1</sub>	S <sub>2</sub>	h	k <sub>3</sub>	k <sub>4</sub>	l (max.)
VEE2-1-1-0.6	1.0	0.9	0.6(6)	1	1000	360	6	6	10	650	1305	645	175
2													
3													
4													
VEE2-1-1-1.0	1.0	1.0	1.0(10)	2	1000	360	6	8	12	650	1315	645	175
3													
4													
6													

Development of design documentation and manufacture of vessels operating under pressure above 1.0 MPa are carried out individually, according to the data sheet sent to our address by the Customer.



## Vertical All-Welded Vessels with Elliptic Head and Cover

Table 1.19 (cont.)

Designation	Volume, m <sup>3</sup>		Nominal pressure, MPa (kgf/cm <sup>2</sup> )	Material make code	Dimensions, mm								
	Nominal	Operating			D	R	S	S <sub>1</sub>	S <sub>2</sub>	h	k <sub>3</sub>	k <sub>4</sub>	l (max.)
VEE2-1-2-0.6	2.0	1.8	0.6(6)	2	1200	450	6	6	10	1100	1810	745	180
3													
4													
VEE2-1-2-1.0	2.0	1.8	1.0(10)	2	1200	450	8	8	12	1100	1765	745	180
3				6									
4													
VEE2-1-3.2-0.6	3.2	3.0	0.6(6)	2	1400	520	6	8	10	1400	2120	845	180
3													
4													
VEE2-1-3.2-1.0	3.2	3.0	1.0(10)	2	1400	520	8	10	14	1400	2130	845	180
3				8									
4													

Main dimensions and weights of vessels on lug supports

Table 1.20

Designation	Material make code	Dimensions, mm					Weight, kg			Allowable medium density, kg/m <sup>3</sup>	
		D <sub>1</sub>	h <sub>1</sub>	L	B	H	Stainless steel parts	Total	Vessel operation weight (not more)		
VEE2-1-1-0.6	1	1210	435	1250	1315	1805	-	540	2600	2000	
	2						525				
	3										
	4										
VEE2-1-1-1.0	2	1210	435	1250	1315	1805	-	650	2760	2000	
	3	1220		1260	1320		665	680	2790		
	4	1210		1250	1315		615	630	2740		
VEE2-1-2-0.6	2	1442	520	1535	1540	2305	-	795	5000	2000	
	3						765				
	4										
VEE2-1-2-1.0	2	1450	520	1535	1540	2305	-	1025	5290	2000	
	3	995									
	4	1442					920	960	5210		
VEE2-1-3.2-0.6	2	1640	520	1735	1740	2705	-	1080	7120	1750	
	3						1040		6630	1600	
	4						7950	8360	2000		
VEE2-1-3.2-1.0	2	1650	520	1740	2705	-	1410			8360	2000
	3					1370					
	4					1330	1370				





Main dimensions and weights of vessels on leg supports

Table 1.21

Designation	Material make code	Dimensions, mm						Stainless steel parts	Weight, kg		Allowable medium density, kg/m <sup>3</sup>
		D <sub>2</sub>	h <sub>2</sub>	d	L	B	H		Total	Vessel operation weight	
VEE2-1-1-0.6	1	920	415	19	1205	1230	1805	-	545	2460	2000
	2							525			
	3										
	4										
VEE2-1-1-1.0	2	920	420	19	1210	1240	1805	-	660	2580	2000
	3							665			
	4										
	4							615			
VEE2-1-2-0.6	2	1100	510	24	1390	1410	2305	-	810	4600	2000
	3							765			
	4										
	4										
VEE2-1-2-1.0	2	1100	510	24	1400	1420	2305	-	1040	4830	2000
	3							995			
	4										
	4							920			
VEE2-1-3.2-0.6	2	1260	560	24	1575	1590	2705	-	1100	7370	2000
	3							1040			
	4										
	4										
VEE2-1-3.2-1.0	2	1260	565	24	1585	1600	2705	-	1425	7500	1950
	3							1370			
	4										
	4							1330			
VEE2-1-3.2-1.0	2	1260	565	24	1585	1600	2705	-	1425	7500	1950
	3							1370			
	4										
	4							1330			

Allowable operating pressure inside the vessel and allowable external pressure occurring due to the formation of vacuum in the vessel

Table 1.22

Designation	Material make code	Maximum allowed pressure, MPa (kgf/cm <sup>2</sup> )					External at wall temperature 300 °C
		At wall temperature value, °C					
		100	150	200	250	300	
VEE2-1-1-0.6	1.2	0.6(6)	0.58(5.8)	0.56(5.6)	0.54(5.4)	0.5(5)	0.099(0.99)
	3.4					0.52(5.2)	
VEE2-1-1-1.0	2	1.0(10)	0.96(9.6)	0.93(9.3)	0.9(9)	0.75(7.5)	0.091(0.91)
	3.4					0.86(8.6)	0.099(0.99)
VEE2-1-2-0.6	2	0.6(6)	0.58(5.8)	0.56(5.6)	0.54(5.4)	0.5(5)	0.057(0.57)
	3.4					0.52(5.2)	0.064(0.64)
VEE2-1-2-1.0	2	1.0(10)	0.96(9.6)	0.93(9.3)	0.9(9)	0.75(7.5)	0.099(0.99)
	3					0.86(8.6)	
	4						0.064(0.64)
VEE2-1-3.2-0.6	2	0.6(6)	0.58(5.8)	0.56(5.6)	0.54(5.4)	0.49(4.9)	0.032(0.32)
	3			0.54(5.4)	0.51(5.1)	0.47(4.7)	
	4			0.56(5.6)	0.54(5.4)	0.52(5.2)	
VEE2-1-3.2-1.0	2	1.0(10)	0.96(9.6)	0.93(9.3)	0.9(9)	0.75(7.5)	0.099(0.99)
	3.4					0.86(8.6)	



# Vertical All-Welded Vessels with Elliptic Head and Cover, with Jacket

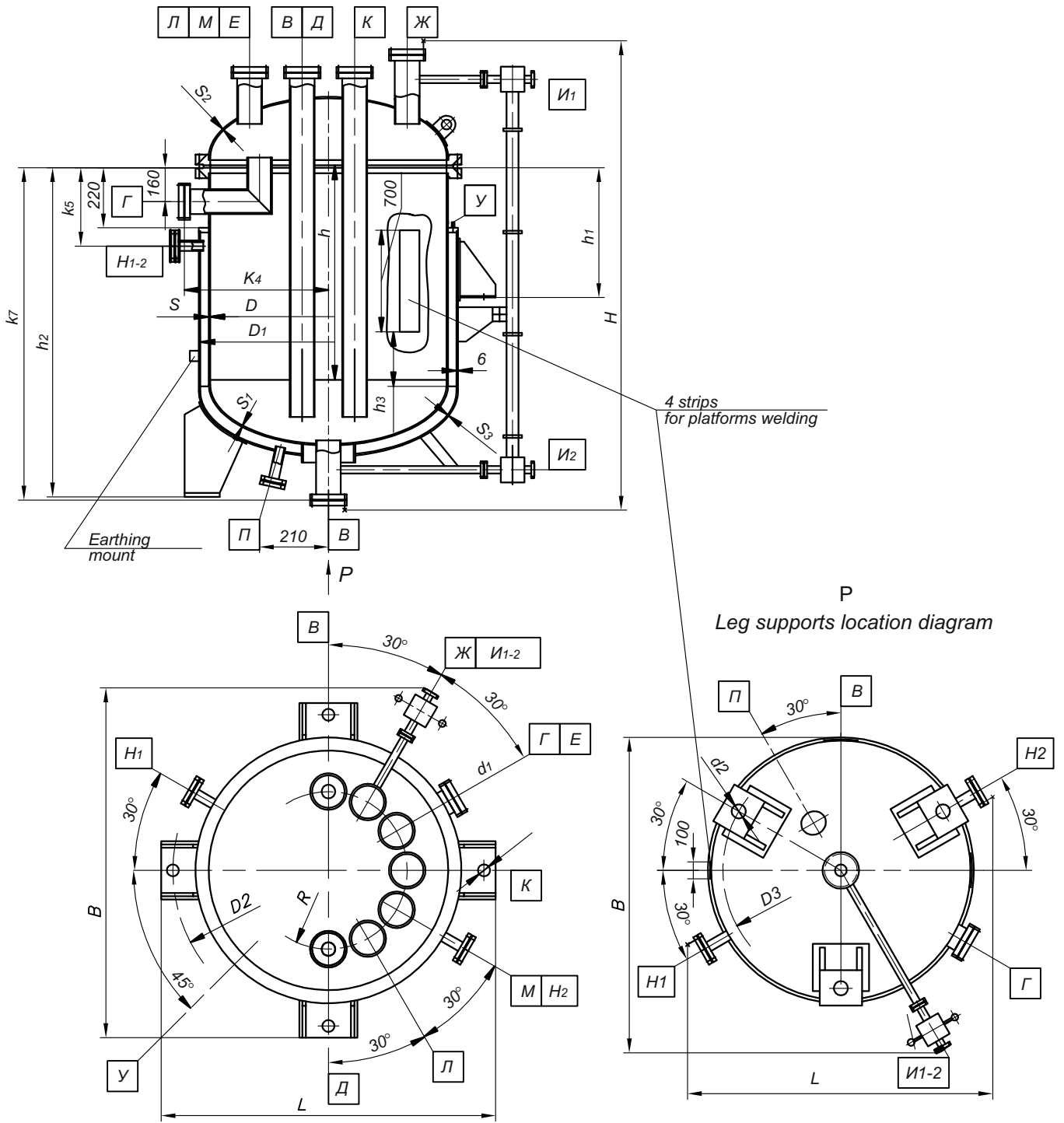

Fig. 1.6

Development of design documentation and manufacture of vessels operating under pressure above 1.6 MPa are carried out individually, according to the data sheet sent to our address by the Customer.



## Vertical All-Welded Vessels with Elliptic Head and Cover, with Jacket

Main dimensions of vessels, heat exchanging surface area

Table 1.23

Designation	Volume, m <sup>3</sup>		Nominal pressure, MPa (kgf/cm <sup>2</sup> )	Dimensions, mm									
	Nominal	Operating		D	D <sub>1</sub>	S <sub>1</sub>	S <sub>2</sub>	S <sub>3</sub>	h	h <sub>3</sub>	k <sub>4</sub>	R	L (max.)
BЭЭ2-3-1-1.0	1	0.91	3.4	1000	1100	12	6	6	835	-	645	360	155
BЭЭ2-3-2-1.0	2	1.9	4.7	1200	1300	12	8	8	1245	40	745	450	150
BЭЭ2-3-3.2-1.0	3	2.9	7.3	1400	1500	14	8	8	1445	200	845	520	215

Main dimensions and weights of vessels with leg supports

Table 1.24

Designation	Material make code	S	S <sub>1</sub>	k <sub>5</sub>	k <sub>7</sub>	D <sub>2</sub>	h <sub>1</sub>	d <sub>1</sub>	L	B	H	Weight, kg			Allowable medium density, kg/m <sup>3</sup>
												Stainless steel parts	Total with supports	Vessel operation weight	
BЭЭ2-3-1-1.0	1	12	12	270	1290	1315	450	24	1355	1355	1805	-	990	3300	2000
	2											770	1000	3310	
	3														
	4														
BЭЭ2-3-2-1.0	1	12	14	630	1815	1545	860	24	1640	1640	2305	-	1550	6090	2000
	2		12									1185	1540	6080	
	3														
	4														
BЭЭ2-3-3.2-1.0	1	14	14	460	2010	1805	695	35	1900	1900	2510	-	2170	8080	1690
	2					1745		24	1840	1840		1600	2155	9040	2000
	3														
	4														



## Vertical All-Welded Vessels with Elliptic Head and Cover, with Jacket

Main dimensions and weights of vessels with leg supports

Table 1.25

Designation	Material make code	S	S <sub>1</sub>	k <sub>5</sub>	k <sub>7</sub>	D <sub>2</sub>	h <sub>1</sub>	d <sub>1</sub>	L	B	H	Weight, kg			Allowable medium density, kg/m <sup>3</sup>
												Stainless steel parts	Total with supports	Vessel operation weight	
VEE2-3-1-1.0	1	12	12	270	1290	1000	1300	19	1330	1255	1805	-	990	2990	1690
	2											770	1000	3000	
	3														
	4														
VEE2-3-2-1.0	1	12	14	630	1815	1200	1845	24	1505	1445	2325	-	1570	6110	2000
	2		12									1185	1560	6100	
	3														
	4														
VEE2-3-3.2-1.0	1	14	14	460	2010	1360	2105	35	1680	1630	2590	-	2195	9080	2000
	2											1660	2110	9090	
	3														
	4														

Allowable operating pressure inside the vessel and allowable external pressure occurring due to the formation of vacuum in the vessel

Table 1.26

Designation	Material make code	Maximum allowed pressure, MPa (kgf/cm <sup>2</sup> )						External at wall temperature 300 °C
		At wall temperature value, °C						
		100	150	200	250	300		
VEE2-3-1-1.0	1	1.0(10)	0.96(9.6)	0.93(9.3)	0.9(9.0)	0.75(7.5)	0.099(0.99)	
	2							
	3							
	4							
VEE2-3-2-1.0	1	1(10)	0.96(9.6)	0.93(9.3)	0.9(9.0)	0.75(7.5)	0.007(0.07)	
	2					0.86(8.6)	0.026(0.26)	
	3						0.004(0.04)	
	4						0.005(0.05)	
VEE2-3-3.2-1.0	1	1.0(10)	0.96(9.6)	0.93(9.3)	0.9(9.0)	0.75(7.5)	0.012(0.12)	
	2					0.86(8.6)	0.024(0.24)	
	3						0.086(0.86)	
	4						0.099(0.99)	



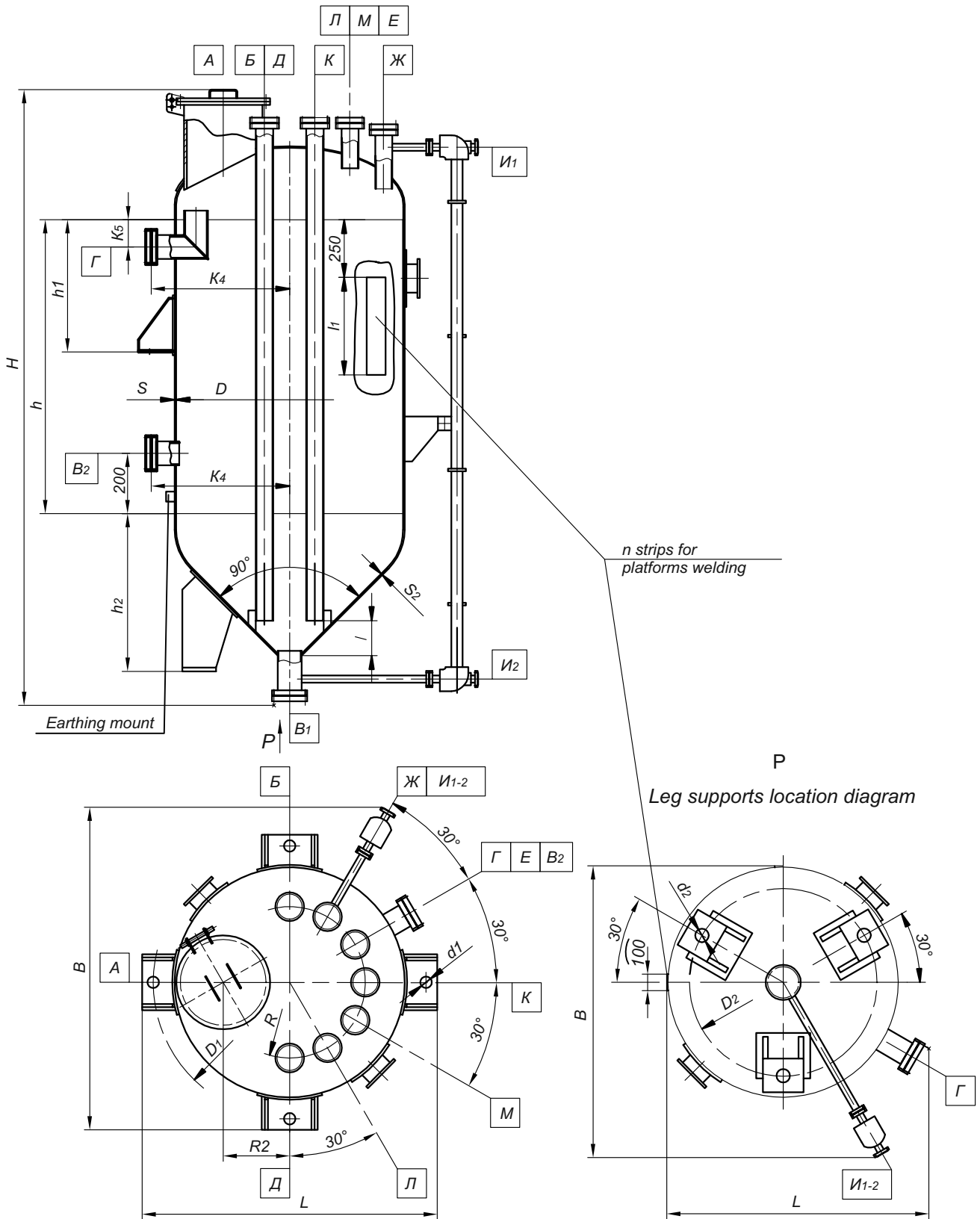

Fig. 1.7



# Vertical All-Welded Vessels with Lower Conical (90°) Beaded and Upper Elliptic Bottom Heads

Vessels designations and main dimensions

Table 1.27

Designation	Volume, m <sup>3</sup>		Dimensions, mm								
	Nominal	Operating	D	h	k <sub>4</sub>	k <sub>5</sub>	R <sub>1</sub>	R <sub>2</sub>	l (max.)	h <sub>1</sub>	n
VKE1-1-1-0.6	1	0.88	1000	800	645	150	360	180	430	-	-
VKE1-1-1-1.0											
VKE1-1-2-0.6	2	1.8	1200	1250	745	150	450	260	535	700	4
VKE1-1-2-1.0											
VKE1-1-3.2-0.6	3.2	2.8	1400	1400	845	150	520	340	625	700	4
VKE1-1-3.2-1.0											
VKE1-1-5-0.6	5	4.5	1600	1800	975	200	580	360	730	700	4
VKE1-1-5-1.0											
VKE1-1-6.3-0.6	6.3	5.7	1600	2400	975	200	580	360	730	700	4
VKE1-1-6.3-1.0											
VKE1-1-10-0.6	10	8.6	2000	2200	1175	200	740	520	910	1000	8
VKE1-1-10-1.0											

Development of design documentation and manufacture of vessels operating under pressure above 1.0 MPa are carried out individually, according to the data sheet sent to our address by the Customer.

Table 1.27 (cont.)

Designation	Material make code	Dimensions, mm		
		S	S <sub>1</sub>	S <sub>2</sub>
VKE1-1-1-0.6	1	6	6	6
	2			
	3			
	4			
VKE1-1-1-1.0	2	6	8	8
	3		6	6
	4		6	6
VKE1-1-2-0.6	1	6	6	6
	2			
	3			
	4			
VKE1-1-2-1.0	2	8	8	8
	3			
	4			
VKE1-1-3.2-0.6	2	6	8	8
	3			6
	4			6
VKE1-1-3.2-1.0	2	8	10	10
	3			8
	4			8

Table 1.27 (cont.)

Designation	Material make code	Dimensions, mm		
		S	S <sub>1</sub>	S <sub>2</sub>
VKE1-1-5-0.6	1	8	8	8
	2			
	3			
	4			
VKE1-1-5-1.0	2	10	10	10
	3			
	4			
VKE1-1-6.3-0.6	1	8	8	8
	2			
	3			
	4			
VKE1-1-6.3-1.0	2	10	10	10
	3			
	4			
VKE1-1-10-0.6	2	8	10	10
	3			8
	4			8
VKE1-1-10-1.0	2	10	12	12
	3			10
	4			10



# Vertical All-Welded Vessels with Lower Conical (90°) Beaded and Upper Elliptic Bottom Heads

Main dimensions and weights of vessels

Table 1.28

Designation	Material make code	D <sub>1</sub>	h <sub>1</sub>	d <sub>1</sub>	L	B	H	Weight, kg			Allowable medium density, kg/m <sup>3</sup>
								Stainless steel parts	Total with supports	Vessel operation weight	
VKE1-1-1-0.6	1	1210	350	24	1250	1315	2150	-	440	2550	2000
	2						2170	415	435	2540	
	3						2155	-	505	2610	
VKE1-1-1-1.0	2	1210					2175	480	500	2650	
	3						445	460	2570		
	4						2730	-	625	4840	
VKE1-1-2-0.6	2	1442			1535	1540	2750	585	620	4860	
	3						2745	-	780	4830	
	4						2765	750	780	5020	
VKE1-1-2-1.0	2	1445					1540	670	705	4930	
	3						3255	-	845	7140	
	4						3270	805	840	6390	
VKE1-1-3.2-0.6	2	1645	1735	1735	3270	760	795	7290			
	3				3260	-	1045	7570			
	4				3280	1010	1040	7560			
VKE1-1-3.2-1.0	2	1648			1740	1740	3270	920	955	7435	
	3						3860	-	1370	11800	
	4						3550	1300	1350	11800	
VKE1-1-5-0.6	1	1910	1995	1995			3850	-	1660	12150	
	2						3880	1440	1500	12000	
	3						4160	-	1585	13050	
VKE1-1-5-1.0	2	1915			2000	2000	3850	1510	1565	14950	
	3						4170	-	1925	15350	
	4						4200	1850	1915	15350	
VKE1-1-6.3-0.6	1	1910	2005	2005			4200	1650	1715	15150	
	2						4600	-	2140	23700	
	3						4305	2055	2145	23750	
VKE1-1-6.3-1.0	2	1915			2490	2490	4295	1960	2050	23650	
	3						4600	-	2570	24350	
	4						4580	2460	2560	20800	
VKE1-1-10-0.6	2	2370	2495	2495			4630	2305	2405	24100	
	3						4600	-	2570	24350	
	4						4580	2460	2560	20800	
VKE1-1-10-1.0	2	2375			4630	2305	2405	24100			
	3				4600	-	2570	24350			
	4				4580	2460	2560	20800			



## Vertical All-Welded Vessels with Lower Conical (90°) Beaded and Upper Elliptic Bottom Heads

Main dimensions and weights of vessels

Table 1.29

Designation	Material make code	D <sub>2</sub>	h <sub>2</sub>	d <sub>2</sub>	L	B	H	Weight, kg			Allowable medium density, kg/m <sup>3</sup>
								Stainless steel parts	Total with supports	Vessel operation weight	
VKE1-1-1-0.6	1	920	440	19	1140	1200	2150	-	445	2570	2000
	2						2170	415	440	2560	
	3						2155	-	510	2630	
VKE1-1-1-1.0	2		445				2175	480	505	2660	
	3						440	465	2590		
	4										
VKE1-1-2-0.6	2	1100	525	24	1335	1385	2730	-	650	4870	2000
	3						2750	600	645	4860	
	4						2745	-	800	5020	
VKE1-1-2-1.0	2		535				2765	760	800	5050	
	3						680	725	4940		
	4										
VKE1-1-3.2-0.6	2	1260	542	24	1520	1570	3255	-	865	7380	2000
	3						3270	815	860	7370	
	4						3260	-	1070	7500	
VKE1-1-3.2-1.0	2		562				3280	1020	1065	7490	
	3						3270	930	975	7490	
	4										
VKE1-1-5-0.6	1	1410	660	35	1755	1760	3860	-	1395	11900	2000
	2						3550	1310	1380	11850	
	3						3850	-	1685	11950	
VKE1-1-5-1.0	2		670				3880	1600	1680	11950	
	3						1450	1530			
	4										
VKE1-1-6.3-0.6	1	740	740	35	1755	1760	4160	-	1665	15100	2000
	2						3850	1530	1645	15100	
	3						4170	-	2000	15400	
VKE1-1-6.3-1.0	2		750				1765	1870	1990	15350	
	3						1760	1670	1795	15200	
	4										
VKE1-1-10-0.6	2	1810	910	42	2130	2125	4600	-	2320	23950	2000
	3						4305	2110	2330	24000	
	4						4295	2015	2235	23950	
VKE1-1-10-1.0	2		915				4600	-	2570	24550	
	3						4508	2530	2760	24600	
	4						4630	2360	2590	24350	





# Vertical Vessels with Conical (90°) Beaded Bottom Head and Elliptic Cover, with Jacket

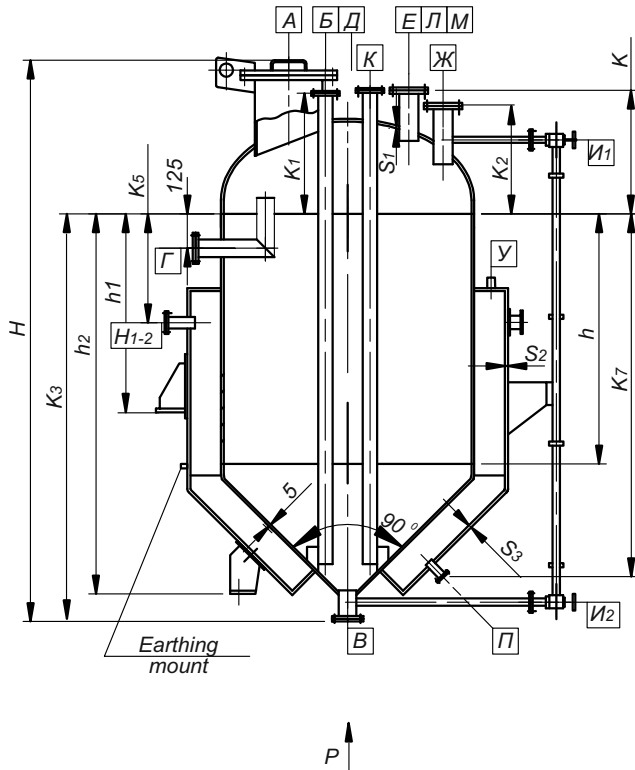

Strips for platforms welding location sketch for vessels with leg supports  
 Volume 2 u 3.2 m<sup>3</sup>      Volume 5;6.3 u 10 m<sup>3</sup>

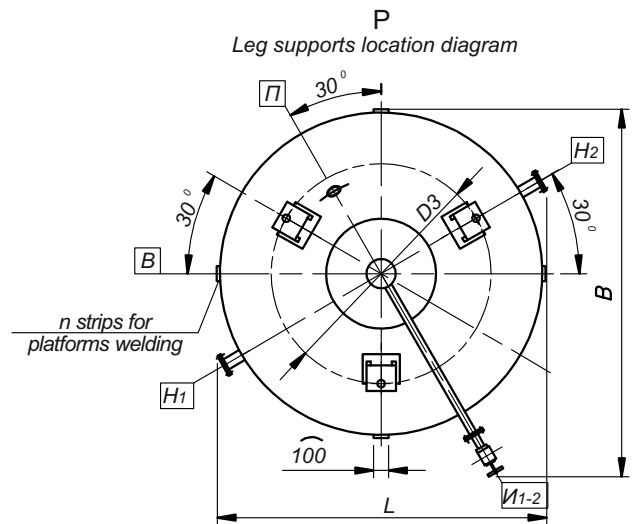
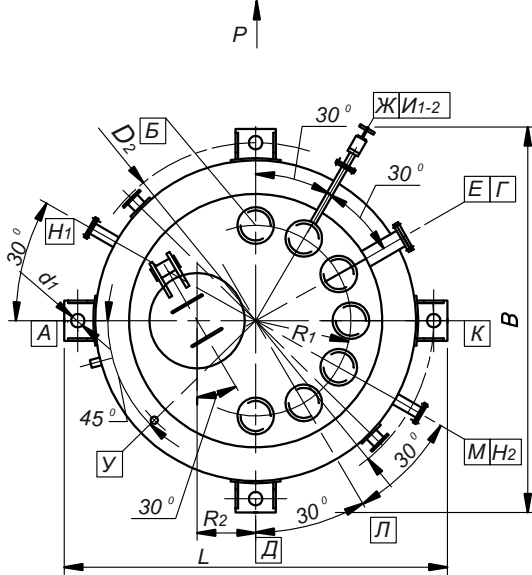
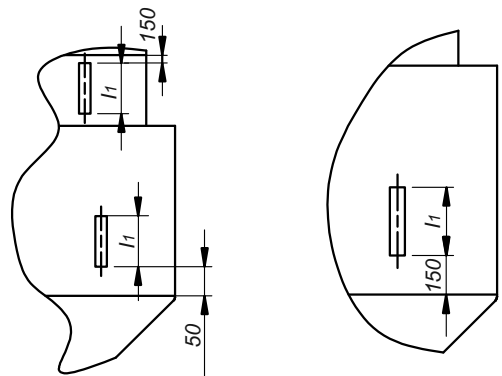

Fig. 1.8

Development of design documentation and manufacture of vessels operating under pressure above 0.6 MPa, 1.6 MPa and higher are carried out individually, according to the data sheet sent to our address by the Customer.



## Vertical All-Welded Vessels with Lower Conical (90°) Beaded and Upper Elliptic Bottom Heads

Allowable operating pressure inside the vessel and allowable external pressure occurring due to the formation of vacuum in the vessel

Table 1.30

Designation	Material make code	Maximum allowed pressure, MPa (kgf/cm <sup>2</sup> )					
		At wall temperature value, °C					External at wall temperature 300 °C
		100	150	200	250	300	
VKE1 -1-1-0.6	1	0.6(6)	0.58(5.8)	0.56(5.6)	0.54(5.4)	0.5(5)	0.067(0.67)
	2					0.52(5.2)	
	3					0.075(0.75)	
VKE1 -1-1-1.0	2	1.0(10)	0.96(9.6)	0.93(9.3)	0.9(9.0)	0.75(7.5)	0.099(0.99)
	3	0.99(9.9)	0.95(9.5)	0.91(9.1)	0.88(8.8)	0.85(8.5)	
	4	1.0(10)	0.96(9.6)	0.93(9.3)	0.83(8.3)	0.8(8)	
VKE1 -1-2-0.6	2	0.6(6)	0.58(5.8)	0.56(5.6)	0.54(5.4)	0.5(5)	0.036(0.36)
	3					0.52(5.2)	
	4					0.04(0.4)	
VKE1 -1-2-1.0	2	1.0(10)	0.96(9.6)	0.93(9.3)	0.9(9.0)	0.75(7.5)	0.099(0.99)
	3	0.98(9.8)	0.93(9.3)	0.9(9)	0.87(8.7)	0.83(8.3)	
	4	1.0(10)	0.96(9.6)	0.93(9.3)	0.9(9)	0.86(8.6)	
VKE1 -1-3.2-0.6	2	0.6(6)	0.58(5.8)	0.56(5.6)	0.54(5.4)	0.5(5)	0.025(0.25)
	3					0.52(5.2)	
	4					0.08(0.8)	
VKE1 -1-3.2-1.0	2	1.0(10)	0.96(9.6)	0.93(9.3)	0.9(9.0)	0.75(7.5)	0.076(0.76)
	3					0.86(8.6)	
	4					0.08(0.8)	
VKE1 -1-5-0.6	1	0.59(5.9)	0.58(5.8)	0.56(5.6)	0.54(5.4)	0.5(5)	0.048(0.48)
	2	0.6(6)				0.52(5.2)	
	3					0.35(3.5)	
	4					0.018(0.18)	
VKE1 -1-5-1.0	2	1.0(10)	0.96(9.6)	0.93(9.3)	0.9(9.0)	0.75(7.5)	0.099(0.99)
	3					0.86(8.6)	
	4					0.054(0.54)	
VKE1 -1-6.3-0.6	1	0.59(5.9)	0.58(5.8)	0.56(5.6)	0.54(5.4)	0.5(5)	0.038(0.38)
	2	0.6(0.6)				0.52(5.2)	
	3					0.042(0.42)	
	4						
VKE1 -1-6.3-1.0	2	1.0(10)	0.96(9.6)	0.93(9.3)	0.9(9.0)	0.75(7.5)	0.085(0.85)
	3					0.86(8.6)	
	4					0.042(0.42)	
VKE1 -1-10-0.6	2	0.6(6)	0.58(5.8)	0.56(5.6)	0.54(5.4)	0.5(5)	0.058(0.58)
	3					0.52(5.2)	
	4					0.064(0.64)	
VKE1 -1-10-1.0	2	1.0(10)	0.96(9.6)	0.93(9.3)	0.9(9.0)	0.75(7.5)	0.058(0.58)
	3	0.98(9.8)	0.93(9.3)	0.89(8.9)	0.86(8.6)	0.82(8.2)	
	4	1.0(10)	0.96(9.6)	0.93(9.3)	0.9(9)	0.86(8.6)	



## Vertical Vessels with Conical (90°) Beaded Bottom Head and Elliptic Cover, with Jacket

Main dimensions of vessels, area of the heat exchanging surface

Table 1.31

Designation	Volume, m <sup>3</sup>		Heat exchange surface area, m <sup>2</sup>	D	D <sub>1</sub>	S	S <sub>2</sub>	S <sub>3</sub>	R <sub>1</sub>	R <sub>2</sub>	l (max.)	l <sub>1</sub>	n
	Nominal	Operating											
VKE 1-3-1-1.0	1	1.05	3.1	1000	1100	12	6	6	360	180	430	-	-
VKE 1-3-2-1.0	2	1.95	3.4	1200	1300	12	6	6	450	260	535	350	8
VKE 1-3-3.2-1.0	3.2	2.95	5.3	1400	1500	14	6	8	520	340	625	350	8
VKE 1-3-5-1.0	5	5.05	8.4	1600	1700	16	8	8	580	360	730	700	4
VKE 1-3-6.3-1.0	6.3	6.45	12.6	1600	1700	18	8	8	580	360	730	700	4
VKE 2-3-10-1.0	10	9.5	16.6	2000	2200	20	10	10	740	520	910	1000	8

Main dimensions and weights of vessels

Table 1.32

Designation	Material make code	S <sub>1</sub>	D <sub>2</sub>	h <sub>1</sub>	d <sub>1</sub>	L	B	H	Weight, kg			Allowable medium density, kg/m <sup>3</sup>
									Stainless steel parts	Total with supports	Vessel operation weight	
VKE 1-3-1-1.0	1	8	1315	450	24	1355	1355	2170	-	880	3320	2000
	2							660	890	3330		
	3							640	870	3310		
	4	6										
VKE 1-3-2-1.0	2	8	1545	1160	24	1640	1640	2700	-	1220	5670	2000
	3							960	1230	5680		
	4											
VKE 1-3-3.2-1.0	1	8	1805	1125	35	1900	1900	3005	-	1830	8080	2000
	2		1745		24	1840	1840	3025	1400	1820	8620	
	3								1360	1780	8580	
	4								6			
VKE 1-3-5-1.0	2	10	2000	1300	35	2090	2090	3885	-	2870	13750	2000
	3							2190	2880			
	4							2150	2840			
VKE 1-3-6.3-1.0	2	10	2000	1200	35	2090	2090	4585	-	3825	15950	1710
	3							2860	3830	1720		
	4							2920	3785			
VKE 1-3-10-1.0	2	12	2570	1000	35	2690	2690	4565	-	5570	25200	1780
	3							3930	5580			
	4							3860	5510			



## Vertical Vessels with Conical (90°) Beaded Bottom Head and Elliptic Cover, with Jacket

Main dimensions and weights of vessels

Table 1.33

Designation	Material make code	S <sub>1</sub>	D <sub>3</sub>	h <sub>2</sub>	d <sub>2</sub>	L	B	H	Weight, kg			Allowable medium density, kg/m <sup>3</sup>
									Stainless steel parts	Total with supports	Vessel operation weight	
VKE1-3-1-1.0	1	8	1000	1270	19	1355	1355	2170	-	880	2990	1700
	2			1280				2190	655	890		1690
	3	6		1280	635			870	1710			
	4											
VKE1-3-2-1.0	2	8	1200	1810	24	1505	1445	2700	-	1240	5790	2000
	3			2820				970	1250	5700		
	4											
VKE1-3-3.2-1.0	1	10	1360	2040	35	1680	1630	3005	-	1860	8660	2000
	2			2050				3025	1400	1870		
	3	8		2050	1370			1840	8640			
	4											
VKE1-3-5-1.0	2	10	1510	2500	35	1850	1800	3885	-	2900	12000	1640
	3			2505				3915	2195	2910		1650
	4	8										
VKE1-3-6.3-1.0	2	10	1510	3280	35	1850	1800	4585	-	3915	17000	2000
	3			3285				4615	2880	3920		
	4	8										
VKE1-3-10-1.0	2	12	2010	3110	42	2280	2270	4565	-	5750	27500	2000
	3			3120				4595	3940	5765		
	4	10										

Allowable operating pressure inside the vessel and allowable external pressure occurring due to the formation of vacuum in the vessel

Table 1.34

Designation	Material make code	Maximum allowed pressure, MPa (kgf/cm <sup>2</sup> )					External at wall temperature 300 °C
		At wall temperature value, °C					
		100	150	200	250	300	
VKE 1-3-1-1.0	1	1(10)	0.96(9.6)	0.93(9.3)	0.9(9.0)	0.75(7.5)	0.099(0.99)
	2						
	3						
	4						
VKE 1-3-2-1.0	2	1(10)	0.96(9.6)	0.93(9.3)	0.9(9.0)	0.75(7.5)	0.0017(0.17)
	3		0.94(9.4)	0.9(9.0)	0.87(8.7)	0.83(8.3)	0.0079(0.79)
	4		0.96(9.6)	0.93(9.3)	0.9(9.0)	0.86(8.6)	0.0098(0.98)
VKE 1-3-3.2-1.0	1	1(10)	0.96(9.6)	0.93(9.3)	0.9(9.0)	0.75(7.5)	0.003(0.03)
	2						0.017(0.17)
	3					0.86(8.6)	0.079 (0.79)
	4						0.096 (0.96)
VKE 1-3-5-1.0	2	1(10)	0.96(9.6)	0.93(9.3)	0.9(9.0)	0.75(7.5)	0.099(0.99)
	3					0.86(8.6)	
	4					0.83(8.3)	
VKE 1-3-6.3-1.0	2	1(10)	0.96(9.6)	0.93(9.3)	0.9(9.0)	0.75(7.5)	0.099(0.99)
	3					0.86(8.6)	
	4					0.83(8.3)	
VKE 1-3-10-1.0	2	1(10)	0.96(9.6)	0.93(9.3)	0.9(9.0)	0.75(7.5)	0.042(0.42)
	3					0.86(8.6)	0.099(0.99)
	4						



## Vertical Vessels with Conical (90°) Beaded Bottom Head and Elliptic Cover

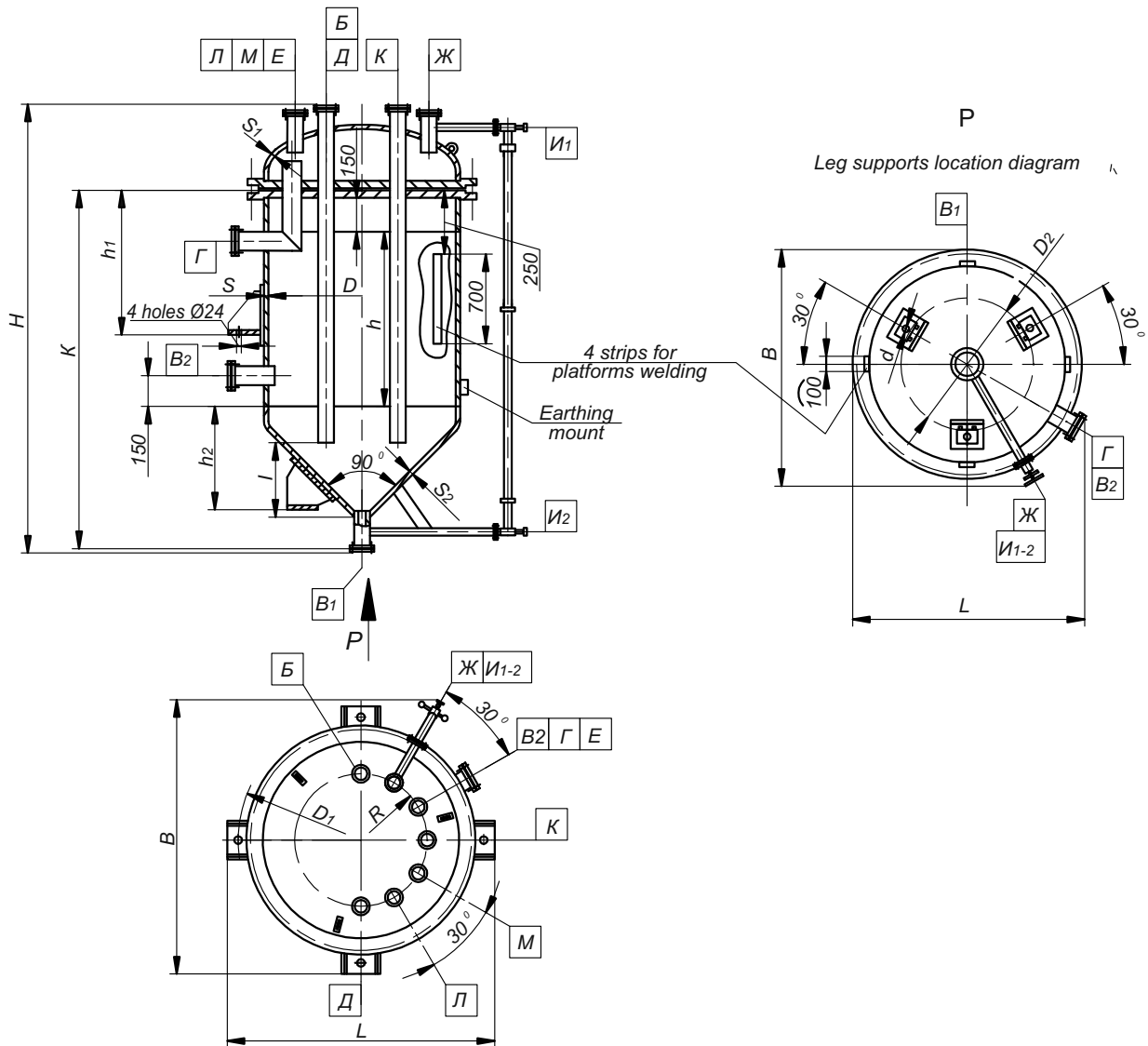

Fig. 1.9

### Main dimensions of vessels, area of the heat exchanging surface

Table 1.35

Designation	Volume, m <sup>3</sup>		Nominal pressure, MPa (kgf/cm <sup>2</sup> )	D	h	L (max.)	R	S <sub>1</sub>
	Nominal	Operating						
VEE2-1-1-0.6	1	0.95	0.6(6)	1000	600	470	360	10
VEE2-1-1-1.0			1(10)					12
VEE2-1-2-0.6	2	1.9	0.6(6)	1200	1000	540	450	10
VEE2-1-2-1.0			1(10)					12
VEE2-1-3.2-0.6	3.2	3	0.6(6)	1400	1250	615	520	10
VEE2-1-3.2-1.0			1(10)					12

Development of design documentation and manufacture of vessels operating under pressure above 1.0 MPa are carried out individually, according to the data sheet sent to our address by the Customer.



# Vertical Vessels with Conical (90°) Beaded Bottom Head and Elliptic Cover

Main dimensions and weights of vessels

Table 1.36

Designation	Material make code	S	S <sub>2</sub>	k	D <sub>1</sub>	h <sub>1</sub>	L	B	H	Weight, kg			Allowable medium density, kg/m <sup>3</sup>		
										Stainless steel parts	Total with supports	Vessel operation weight			
VKE2-1-1-0.6	1	6	6	340	1210	435	1250	1315	2005	-	550	2720	2000		
	2									535					
	3														
	4														
VKE2-1-1-1.0	2	6	8	430	1210	435	1250	1315	2005	-	660	2830	2000		
	3	8			1220		1260	1320		680	695	2860			
	4	6			1210		1250	1315		620	635	2800			
VKE2-1-2-0.6	2	6	6	375	1442	520	1535	1540	2605	-	795	5050	2000		
	3									765					
	4														
VKE2-1-2-1.0	2	8	8	410	1450	520	1535	1545	2605	-	1035	5290	2000		
	3									1005					
	4													6	1442
VKE2-1-3.2-0.6	2	6	8	470	1640	520	1735	1735	2905	-	1065	7100	1700		
	3		6							1035		6570	1600		
	4		6							995		1025	7840		
VKE2-1-3.2-1.0	2	8	10	450	1650	520	1740	1740	2905	-	1380	8200	2000		
	3		8							455		1350		1380	8200
	4											8		1305	1335

Main dimensions and weights of vessels

Table 1.37

Designation	Material make code	S	S <sub>2</sub>	D <sub>2</sub>	h <sub>2</sub>	d	L	B	H	Weight, kg			Allowable medium density, kg/m <sup>3</sup>	
										Stainless steel parts	Total with supports	Vessel operation weight		
VKE2-1-1-0.6	1	6	6	920	445	19	1205	1230	2005	-	555	2720	2000	
	2									535				
	3													
	4													
VKE2-1-1-1.0	2	8	8	450	445	1210	1240	2005	-	665	2830	2000		
	3		6						675				695	2860
	4		6						620				640	2810
VKE2-1-2-0.6	2	6	6	1100	525	24	1390	1410	2605	-	805	5060	2000	
	3									765				
	4													



## Vertical Vessels with Conical (90°) Beaded Bottom Head and Elliptic Cover

Table 1.37 (cont.)

Designation	Material make code	S	S <sub>2</sub>	D <sub>2</sub>	h <sub>2</sub>	d	L	B	H	Weight, kg			Allowable medium density, kg/m <sup>3</sup>
										Stainless steel parts	Total with supports	Vessel operation weight	
VKE2-1-2-1.0	2	8	8	1100	540	24	1400	1402	2605	-	1055	5310	2000
	3									1015			
	4	6	950							990	5250		
VKE2-1-3.2-0.6	2	6	8	1260	560	24	1575	1590	2905	-	1085	7480	1870
	3		6							1045			
	4		6							1005	1045	7470	
VKE2-1-3.2-1.0	2	8	10	1260	580	24	1585	1600	2905	-	1405	7470	1770
	3		8							1365			
	4		8							1315	1355	7480	

Allowable operating pressure inside the vessel and allowable external pressure occurring due to the formation of vacuum in the vessel

Table 1.38

Designation	Material make code	Maximum allowed pressure, MPa (kgf/cm <sup>2</sup> )						External at wall temperature 300 °C
		At wall temperature value, °C					300	
		100	150	200	250	300		
VKE2-1-1-0.6	1	0.6(6)	0.58(5.8)	0.56(5.6)	0.54(5.4)	0.5(5.0)	0.077(0.77)	
	2							
	3					0.52(5.2)	0.085(0.85)	
	4							
VKE2-1-1-1.0	2	1(10)	0.96(9.6)	0.93(9.3)	0.9(9.0)	0.75(7.5)	0.077(0.77)	
	3					0.86(8.6)	0.099(0.99)	
	4					0.86(8.6)	0.085(0.85)	
VKE2-1-2-0.6	1	0.6(6)	0.58(5.8)	0.56(5.6)	0.54(5.4)	0.5(5.0)	0.038(0.38)	
	2							
	3					0.52(5.2)	0.041(0.41)	
	4							
VKE2-1-2-1.0	2	1(10)	0.96(9.6)	0.93(9.3)	0.9(9.0)	0.75(7.5)	0.099(0.99)	
	3					0.86(8.6)	0.041(0.41)	
	4							
VKE2-1-3.2-0.6	2	0.6(6)	0.58(5.8)	0.56(5.6)	0.54(5.4)	0.5(5.0)	0.077(0.77)	
	3			0.54(5.4)	0.51(5.1)	0.47(4.7)	0.099(0.99)	
	4			0.56(5.6)	0.54(5.4)	0.52(5.2)		
VKE2-1-3.2-1.0	2	1(10)	0.96(9.6)	0.93(9.3)	0.9(9.0)	0.75(7.5)	0.099(0.99)	
	3					0.86(8.6)		
	4							



# Vertical Vessels with Conical (90°) Beaded Bottom Head and Elliptic Cover, with Jacket

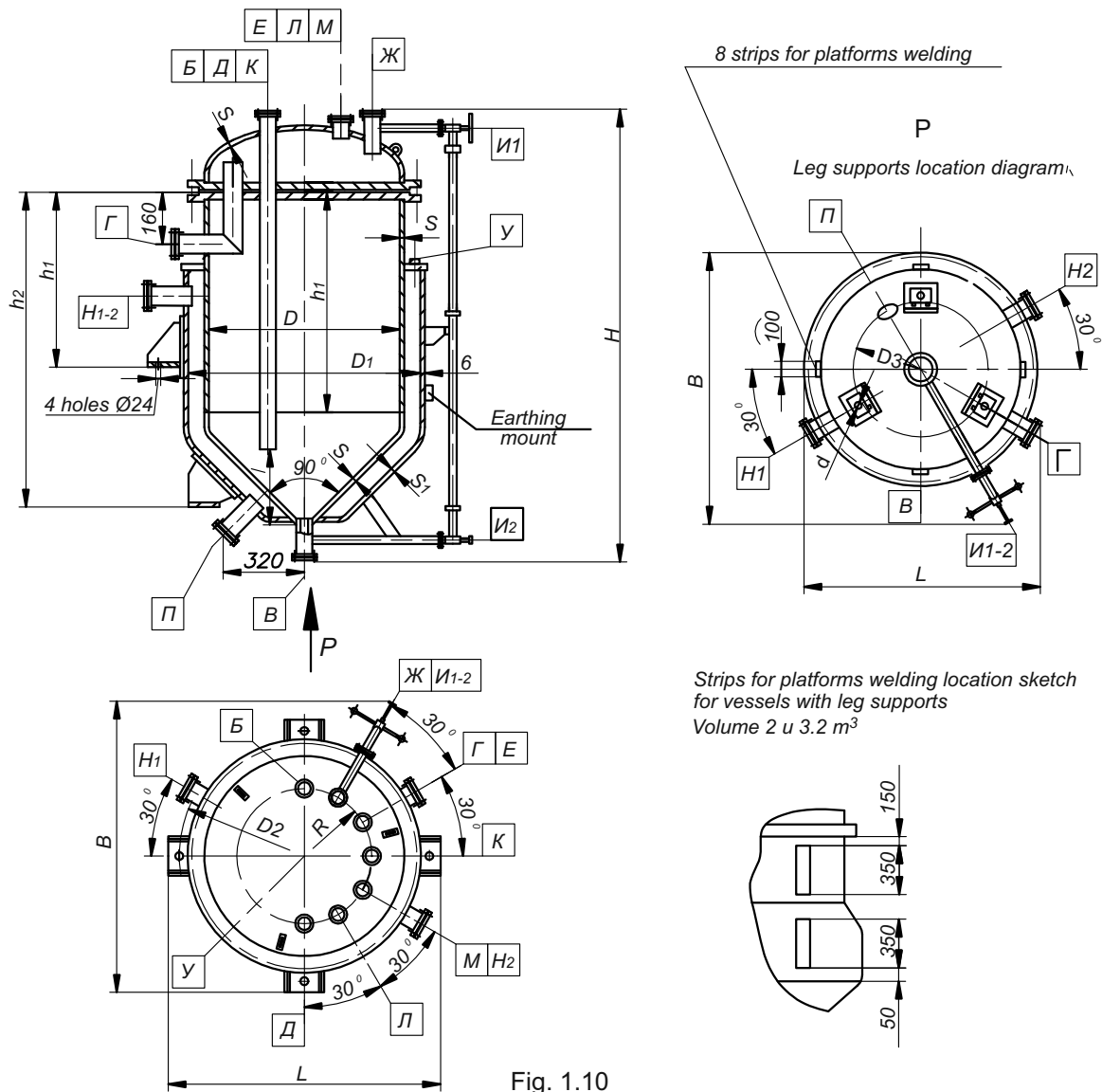

Fig. 1.10

Main dimensions of vessels, area of the heat exchanging surface

Table 1.39

Designation	Volume, m <sup>3</sup>		Heat exchange surface area, m <sup>2</sup>	D	D <sub>1</sub>	S	S <sub>1</sub>	h	R	l (max.)
	Nominal	Operating								
VKE 2-3-1-1.0	1	0.87	3.1	1000	1100	12	6	735	360	430
VKE 2-3-2-1.0	2	1.76	3.4	1200	1300	12	6	1145	450	500
VKE 2-3-3.2-1.0	3.2	2.92	5.3	1400	1500	14	6	1445	520	625

Development of design documentation and manufacture of vessels operating under pressure of 0.6 MPa, 1.6 MPa and higher are carried out individually, according to the data sheet sent to our address by the Customer.





## Vertical Vessels with Conical (90°) Beaded Bottom Head and Elliptic Cover, with Jacket

Main dimensions and weights of vessels

Table 1.40

Designation	Material make code	D <sub>2</sub>	h <sub>1</sub>	L	B	H	Weight, kg			Allowable medium density, kg/m <sup>3</sup>
							Stainless steel parts	Total with supports	Vessel operation weight	
VKE2-3-1-1.0	1	1315	450	1355	1355	1910	-	990	3230	2000
	2						780	1005	3240	
	3									
	4									
VKE2-3-2-1.0	2	1545	1050	1640	1640	2505	-	1420	5760	2000
	3						1170	1435	5770	
	4									
VKE2 -3-3.2-1.0	1	1805	1280	1900	1900	2910	-	2150	8070	1660
	2	1745	1240	1840	1840			2120	9150	2000
	3						1715	2135	9160	
	4									

Main dimensions and weights of vessels

Table 1.41

Designation	Material make code	D <sub>3</sub>	h <sub>2</sub>	d	L	B	H	Weight, kg			Allowable medium density, kg/m <sup>3</sup>
								Stainless steel parts	Total with supports	Vessel operation weight	
VKE2-3-1-1.0	1	1000	1210	19	1330	1255	1910	-	995	2990	1760
	2							780	1010		1740
	3										
	4										
VKE2-3-2-1.0	2	1200	1705	24	1505	1445	2505	-	1440	5780	2000
	3							1175	1455	5790	
	4										
VKE2-3-3.2-1.0	1	1360	2100	35	1680	1630	2910	-	2175	9200	2000
	2							720	2135	9210	
	3										
	4										



## Vertical Vessels with Conical (90°) Beaded Bottom Head and Elliptic Cover, with Jacket

Allowable operating pressure inside the vessel and allowable external pressure occurring due to the formation of vacuum in the vessel

Table 1.42

Designation	Material make code	Maximum allowed pressure, MPa (kgf/cm <sup>2</sup> )						
		At wall temperature value, °C					External at wall temperature 300 °C	
		100	150	200	250	300		
VKE2-3-1-1.0	1	1(10)	0.96(9.6)	0.93(9.3)	0.9(9)	0.75(7.5)	0.097(0.97)	
	2					0.86(8.6)	0.099(0.99)	
	3							
	4							
VKE2-3-2-1.0	2	1(10)	0.96(9.6)	0.93(9.3)	0.9(9)	0.75(7.5)	0.02(0.2)	
	3					0.86(8.6)	0.077(0.77)	
	4							0.097(0.97)
	4							
VKE2-3-3.2-1.0	1	1(10)	0.96(9.6)	0.93(9.3)	0.9(9)	0.75(7.5)	0.01(0.1)	
	2					0.86(8.6)	0.027(0.27)	
	3							0.086(0.86)
	4							



# Horizontal All-Welded Vessels with Spherical Unbeaded Bottom Heads

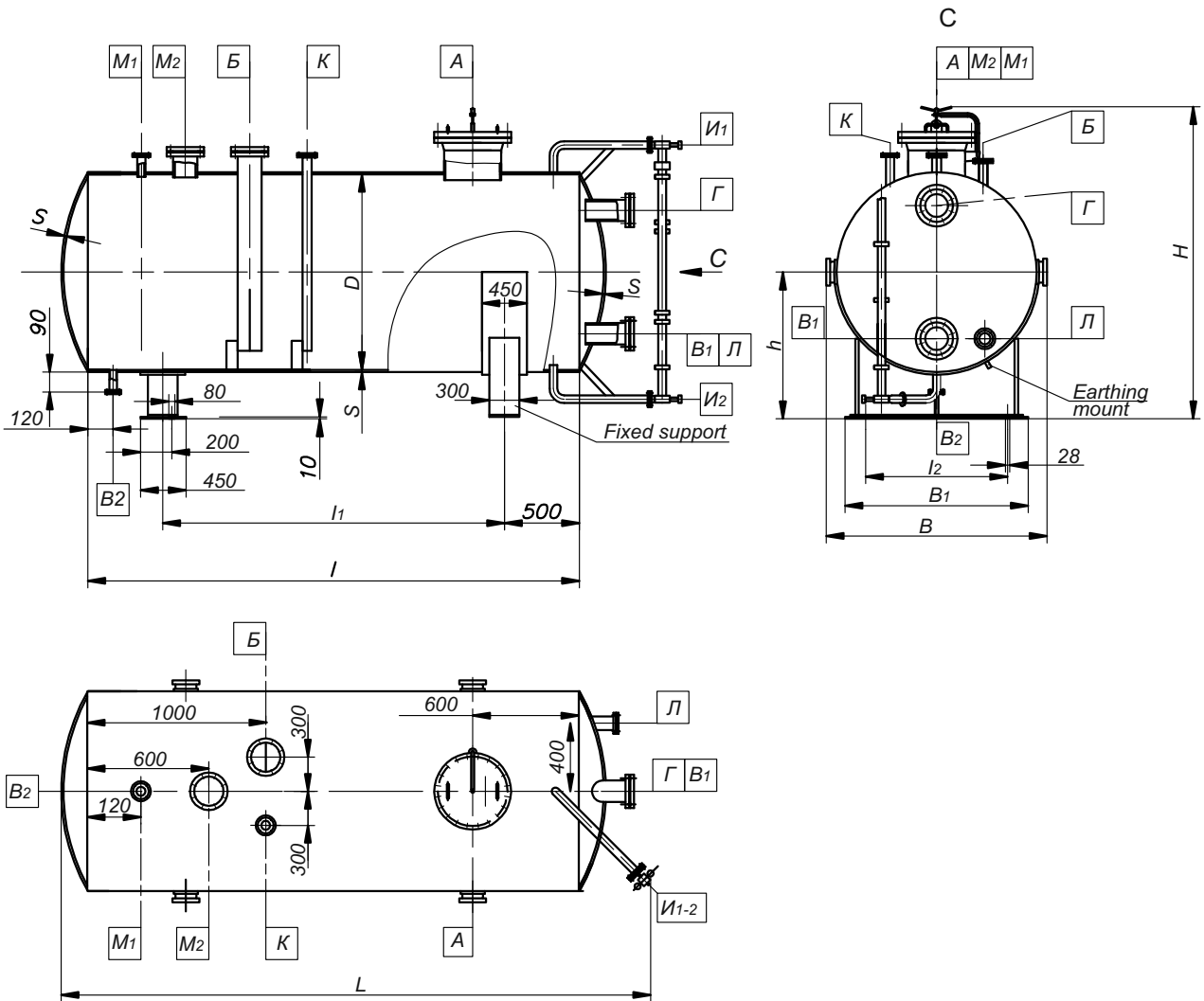

Fig. 1.11

Main dimensions of vessels

Table 1.43

Designation	Volume, m <sup>3</sup>		D	L	L <sub>1</sub>	L <sub>2</sub>	h	B <sub>1</sub>
	Nominal	Operating						
GSS1-1-10-0.07	10	9.1	2000	3000	2000	1500	1325	1790
GSS1-1-16-0.07	16	14.6		5000	4000			
GSS1-1-25-0.07	25	22.8	2400	8500	7500	1800	1425	2140
GSS1-1-40-0.07	40	36.4						
GSS1-1-50-0.07	50	45.5	3000	6500	5500	2200	1730	2660
GSS1-1-63-0.07	63	57.3		8500	7500			
GSS1-1-80-0.07	80	72.8		11000	10000			
GSS1-1-100-0.07	100	91		14000	13000			



## Horizontal All-Welded Vessels with Spherical Unbeaded Bottom Heads

Allowable operating pressure inside the vessel and allowable external pressure occurring due to the formation of vacuum in the vessel

Table 1.44

Designation	Material make code	Maximum allowed pressure, MPa (kgf/cm <sup>2</sup> )						External, at maximum operating temperature
		At wall temperature value, °C						
		100	150	200	250	300		
GSS1-1-10-0.07	1	0.048(0.48)	0.047(0.47)	0.044(0.44)	0.041(0.41)	0.035(0.35)	0.0217(0.217)	
	2	0.062(0.62)	0.059(0.59)	0.056(0.56)	0.054(0.54)	0.048(0.48)	0.0219(0.219)	
	3	0.058(0.58)	0.055(0.55)	0.051(0.51)	0.049(0.49)	0.046(0.46)	0.0245(0.245)	
	4	0.07(0.7)	0.07(0.7)	0.07(0.7)	0.069(0.69)	0.066(0.66)	0.0247(0.247)	
GSS1-1-16-0.07	1	0.048(0.48)	0.047(0.47)	0.044(0.44)	0.041(0.41)	0.035(0.35)	0.0136(0.136)	
	2	0.062(0.62)	0.059(0.59)	0.056(0.56)	0.054(0.54)	0.048(0.48)	0.0139(0.139)	
	3	0.058(0.58)	0.055(0.55)	0.051(0.51)	0.049(0.49)	0.046(0.46)	0.0156(0.156)	
	4	0.07(0.7)	0.07(0.7)	0.07(0.7)	0.069(0.69)	0.066(0.66)	0.0158(0.158)	
GSS1-1-25-0.07	1	0.03(0.3)	0.028(0.28)	0.026(0.26)	0.022(0.22)	-	0.0092(0.092)	
	2	0.043(0.43)	0.04(0.4)	0.037(0.37)	0.035(0.35)	0.03(0.3)	0.0093(0.093)	
	3	0.039(0.39)	0.036(0.36)	0.033(0.33)	0.031(0.31)	0.028(0.28)	0.0105(0.105)	
	4	0.067(0.67)	0.063(0.63)	0.06(0.6)	0.05(0.5)	0.046(0.46)	0.0107(0.107)	
GSS1-1-40-0.07	1	0.03(0.3)	0.028(0.28)	0.026(0.26)	-	-	0.0035(0.035)	
	2	0.043(0.43)	0.04(0.4)	0.037(0.37)	0.035(0.35)	0.03(0.3)	0.0032(0.032)	
	3	0.039(0.39)	0.036(0.36)	0.033(0.33)	0.031(0.31)	0.028(0.28)	0.0039(0.039)	
	4	0.067(0.67)	0.063(0.63)	0.06(0.6)	0.05(0.5)	0.046(0.46)	0.0043(0.043)	
GSS1-1-50-0.07	2	0.047(0.47)	0.043(0.43)	0.04(0.4)	0.038(0.38)	0.031(0.31)	0.011(0.11)	
	3	0.042(0.42)	0.039(0.39)	0.035(0.35)	0.033(0.33)	0.029(0.29)	0.0125(0.125)	
	4	0.07(0.7)	0.07(0.7)	0.067(0.67)	0.055(0.55)	0.051(0.51)	0.0129(0.129)	
GSS1-1-63-0.07	2	0.047(0.47)	0.043(0.43)	0.04(0.4)	0.038(0.38)	0.031(0.31)	0.0072(0.072)	
	3	0.042(0.42)	0.039(0.39)	0.035(0.35)	0.033(0.33)	0.029(0.29)	0.0084(0.084)	
	4	0.07(0.7)	0.07(0.7)	0.067(0.67)	0.055(0.55)	0.051(0.51)	0.0089(0.089)	
GSS1-1-80-0.07	2	0.047(0.47)	0.043(0.43)	0.04(0.4)	0.038(0.38)	0.031(0.31)	0.0032(0.032)	
	3	0.042(0.42)	0.039(0.39)	0.035(0.35)	0.033(0.33)	0.029(0.29)	0.004(0.04)	
	4	0.07(0.7)	0.07(0.7)	0.067(0.67)	0.055(0.55)	0.051(0.51)	0.0046(0.046)	
GSS1-1-100-0.07	1	0.067(0.67)	0.065(0.65)	0.06(0.6)	0.055(0.55)	0.045(0.45)	0.0037(0.037)	
	2	0.07(0.7)	0.07(0.7)	0.07(0.7)	0.07(0.7)	0.067(0.67)	0.005(0.05)	
	3			0.069(0.69)	0.064(0.64)	0.0057(0.57)		
	4			0.067(0.67)	0.055(0.55)	0.051(0.51)	0.0008(0.008)	



## Horizontal All-Welded Vessels with Spherical Unbeaded Bottom Heads

Main dimensions of vessels

Table 1.45

Designation	Material make code	S	L	B	H	Weight, kg			Allowable medium density, kg/m <sup>3</sup>	Maximum operating temperature, °C			
						Stainless steel parts	Total with supports	Vessel operation weight					
GSS1-1-10-0.07	1	8	3720	2170	2665	-	2400	24750	2000	300			
	2				2685	2065							
	3				5720	2665					-		
	4					2685					2815		
GSS1-1-16-0.07	1		5850	2580	2970	-	4095	45000			1670	250	
	2				2990	3590		50200			1890	300	
	3				9350	2970		-			5785		48800
	4											2990	4995
GSS1-1-25-0.07	1	9350	2580	2970	-	5785	70500	1600	200				
	2			7540	3580		-	7675	76700	1760			
	3								3600	6905	9200	74400	1700
	4			3580	-		9200	80000	1800				
GSS1-1-40-0.07	1	10	9540	3205	3580	-	9200	119700	1740	300			
	2				12040	3580		-	11130		116000	1680	
	3										3600	8435	126000
	4				3580	-		11130	144800		1640		
GSS1-1-50-0.07	1	12	15040	3210	3580	-	15570	180000	1600				
	2				3205	3600				14665	13330		
	3			3600								10225	11130
	4			3600	10225	11130				173400	2000		



# Vertical All-Welded Vessels with Lower Conical (90°) Unbeaded and Upper Flat (Spherical) Bottom Heads

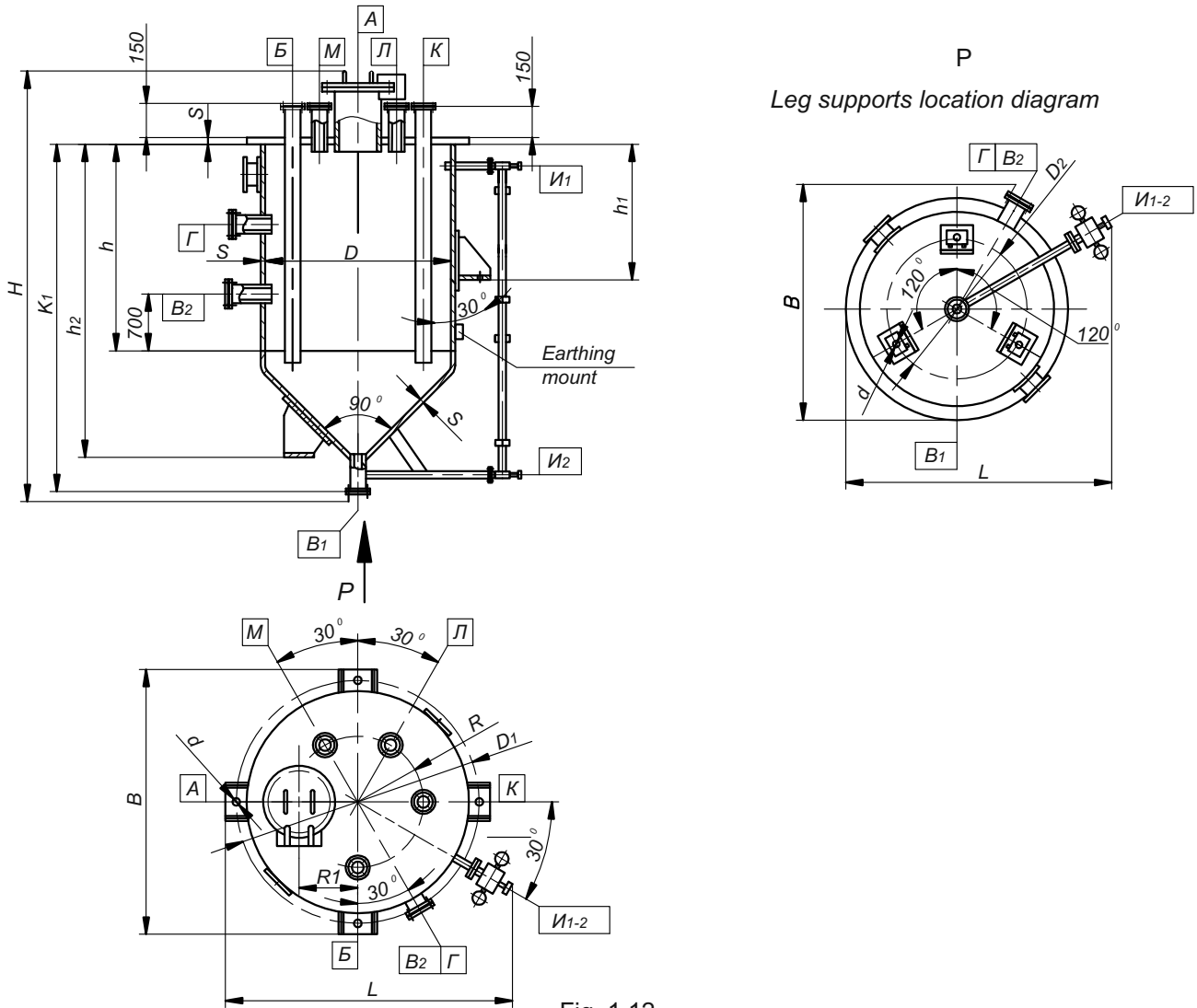

Fig. 1.12

Main dimensions of vessels

Table 1.46

Designation	Volume, m <sup>3</sup>		D	h	R	R <sub>1</sub>	K <sub>1</sub>	d
	Nominal	Operating						
VKP1-1-10-0	10	8.7	2200	2200	800	600	3340	35
VKP1-1-16-0	16	14.1	2600	2500	950	750	3840	42
VKP1-1-25-0	25	23	2800	3600	1000	850	5040	

Development of design documentation and manufacture of vessels with the volume of more than 25 m<sup>3</sup> are carried out individually, according to the data sheet sent to our address by the Customer.



## Vertical All-Welded Vessels with Lower Conical (90°) Unbeaded and Upper Flat (Spherical) Bottom Heads

Main dimensions and weights of vessels

Table 1.47

Designation	Material make code	Dimensions, mm						Weight, kg				Allowable medium density, kg/m <sup>3</sup>
		S	h	D <sub>1</sub>	L	B	H	Stainless steel parts	Two-layer steel parts	Total	Vessel operation weight (not more)	
VKP1-1-10-0	1	8	600	2570	2690	2690	3805	-	-	2040	22250	2000
	2						3825	1950				
	3											
	4											
VKP1-1-16-0	1	8	800	3120	3250	3250	4305	-	-	2780	29700	1670
	2						4325	2580			34800	2000
	3											
	4											
VKP1-1-25-0	1	8	800	3485	3615	3615	5505	-	-	3930	45900	1630
	2						5525	3560			46650	1650
	3											
	4											

Main dimensions and weights of vessels

Table 1.48

Designation	Material make code	Dimensions, mm						Weight, kg				Allowable medium density, kg/m <sup>3</sup>
		S	h <sub>2</sub>	D <sub>2</sub>	L	B	H	Stainless steel parts	Two-layer steel parts	Total	Vessel operation weight (not more)	
VKP1-1-10-0	1	8	2810	2010	2360	2365	3805	-	-	2040	22250	2000
	2						3825	1930				
	3											
	4											
VKP1-1-16-0	1	8	3260	2410	2730	2740	4305	-	-	2730	34750	2000
	2						4325	2530				
	3											
	4											
VKP1-1-25-0	1	8	4560	2610	2920	2925	5505	-	-	3920	55150	2000
	2						5525	3470				
	3											
	4											



## Vertical All-Welded Vessels with Lower Conical (90°) Unbeaded and Upper Flat (Spherical) Bottom Heads

Allowable operating pressure inside the vessel and allowable external pressure occurring due to the formation of vacuum in the vessel

Table 1.49

Designation	Material make code	Allowable pressures of gas phase inside the vessel and outside on the vessel, MPa (kgf/cm <sup>2</sup> ), at the vessel wall temperature, °C				
		100	150	200	250	300
VKP1-1-10-0 VKP1-4-10-0	1	0.0022 (0.022)	0.0022 (0.022)	0.0021 (0.021)	0.002 (0.02)	0.0018 (0.018)
	2	0.0027 (0.027)	0.0026 (0.026)	0.0025 (0.025)	0.0024 (0.024)	0.0022 (0.022)
	3	0.0025 (0.025)	0.0024 (0.024)	0.0023 (0.023)	0.0023 (0.023)	0.0022 (0.022)
	4	0.0035 (0.035)	0.0033 (0.033)	0.0032 (0.032)	0.0029 (0.029)	0.0028 (0.028)
VKP1-1-16-0 VKP1-4-16-0	1	0.0017 (0.017)	0.0016 (0.016)	0.0015 (0.015)	0.0015 (0.015)	0.0013 (0.013)
	2	0.002 (0.02)	0.0019 (0.019)	0.0018 (0.018)	0.0018 (0.018)	0.0017 (0.017)
	3	0.0019 (0.019)	0.0018 (0.018)	0.0017 (0.017)	0.0017 (0.017)	0.0016 (0.016)
	4	0.0026 (0.026)	0.0025 (0.025)	0.0024 (0.024)	0.0021 (0.021)	0.0021 (0.021)
VKP1-1-25-0 VKP1-4-25-0	1*	0.0014 (0.014)	-	-	-	-
	2	0.0017 (0.017)	0.0017 (0.017)	0.0016 (0.016)	0.0016 (0.016)	0.0014 (0.014)
	3**	0.0016 (0.016)	0.0016 (0.016)	0.0015 (0.015)	0.0015 (0.015)	-
	4	0.0022 (0.022)	0.0022 (0.022)	0.0021 (0.021)	0.0019 (0.019)	0.0018 (0.018)

\* Maximum operating temperature 100 °C.

\*\* Maximum operating temperature 250 °C.





# Vertical All-Welded Vessels with Lower Conical (90°) Unbeaded and Upper Flat (Spherical) Bottom Heads, with Coil

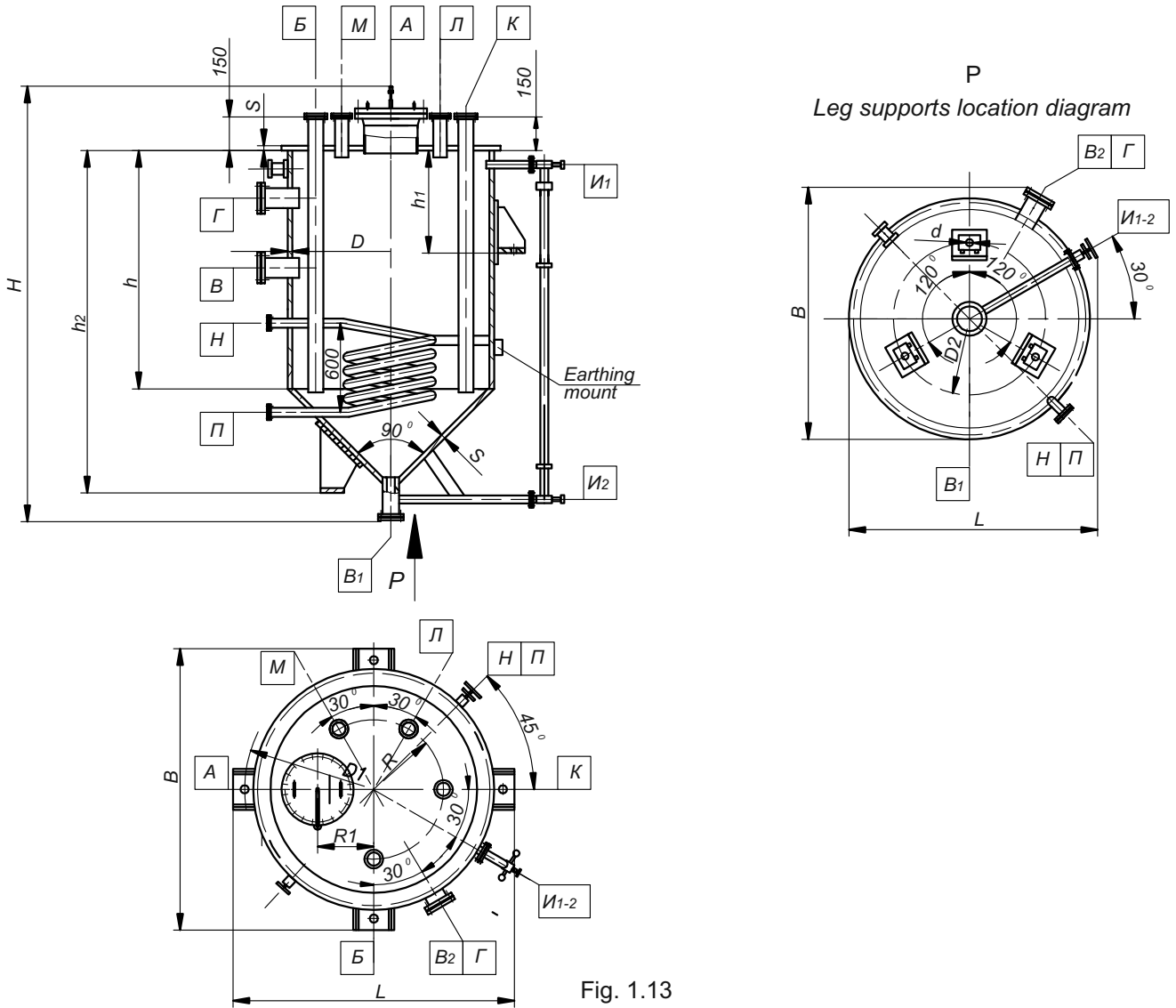

Fig. 1.13

Main dimensions of vessels, area of the heat exchanging surface

Table 1.50

Designation	Volume, m <sup>3</sup>		Heat exchange surface area, m <sup>2</sup>	D	h	R	R <sub>1</sub>	d
	Nominal	Operating						
VKP 1-4-10-0	10	8.7	2.9	2200	2200	800	600	35
VKP 1-4-16-0	16	14.1	3.5	2600	2500	950	750	42
VKP 1-4-25-0	25	23		2800	3600	1000	850	

Development of design documentation and manufacture of vessels with the volume of more than 25 m<sup>3</sup> are carried out individually, according to the data sheet sent to our address by the Customer.



## Vertical All-Welded Vessels with Lower Conical (90°) Unbeaded and Upper Flat (Spherical) Bottom Heads, with Coil

Main dimensions and weights of vessels

Table 1.51

Designation	Material make code	S	h <sub>1</sub>	D <sub>1</sub>	L	B	H	Weight, kg			Allowable medium density, kg/m <sup>3</sup>
								Stainless steel parts	Total with supports	Vessel operation weight	
VKP1-4-10-0	1	8	600	2570	2690	2690	3805	-	2120	22250	2000
	2						3825	2030			
	3										
	4										
VKP1-4-16-0	1		800	3120	3250	3250	4305	-	2870	29700	
	2						4325	2670		34800	
	3										
	4										
VKP1-4-25-0	1	800	3485	3615	3615	5505	-	4020	45900	1630	
	2					5525	3650		46650	1650	
	3										
	4										54900

Main dimensions and weights of vessels

Table 1.52

Designation	Material make code	S	h <sub>2</sub>	D <sub>2</sub>	L	B	H	Weight, kg			Allowable medium density, kg/m <sup>3</sup>	
								Stainless steel parts	Total with supports	Vessel operation weight		
VKP1-4-10-0	1	8	2810	2010	2360	2365	3805	-	2120	22250	2000	
	2						3825	2010				
	3											
	4											
VKP1-4-16-0	1		800	3260	2410	2730	2740	4305	-	2820		34750
	2							4325	2620			
	3											
	4											
VKP1-4-25-0	1	800	4560	2610	2920	2925	5505	-	4010	55150		
	2						5525	3560				
	3											
	4											



## Vertical All-Welded Vessels with Lower Conical (90°) Unbeaded and Upper Flat (Spherical) Bottom Heads, with Coil

Allowable operating pressure inside the vessel and allowable external pressure occurring due to the formation of vacuum in the vessel

Table 1.53

Designation	Material make code	Allowable pressures of gas phase inside the vessel and outside on the vessel, MPa (kgf/cm <sup>2</sup> ), at the vessel wall temperature, °C				
		100	150	200	250	300
VKP1-1-10-0 VKP1-4-10-0	1	0.0022 (0.022)	0.0022 (0.022)	0.0021 (0.021)	0.002 (0.02)	0.0018 (0.018)
	2	0.0027 (0.027)	0.0026 (0.026)	0.0025 (0.025)	0.0024 (0.024)	0.0022 (0.022)
	3	0.0025 (0.025)	0.0024 (0.024)	0.0023 (0.023)	0.0023 (0.023)	0.0022 (0.022)
	4	0.0035 (0.035)	0.0033 (0.033)	0.0032 (0.032)	0.0029 (0.029)	0.0028 (0.028)
VKP1-1-16-0 VKP1-4-16-0	1	0.0017 (0.017)	0.0016 (0.016)	0.0015 (0.015)	0.0015 (0.015)	0.0013 (0.013)
	2	0.002 (0.02)	0.0019 (0.019)	0.0018 (0.018)	0.0018 (0.018)	0.0017 (0.017)
	3	0.0019 (0.019)	0.0018 (0.018)	0.0017 (0.017)	0.0017 (0.017)	0.0016 (0.016)
	4	0.0026 (0.026)	0.0025 (0.025)	0.0024 (0.024)	0.0021 (0.021)	0.0021 (0.021)
VKP1-1-25-0 VKP1-4-25-0	1*	0.0014 (0.014)	-	-	-	-
	2	0.0017 (0.017)	0.0017 (0.017)	0.0016 (0.016)	0.0016 (0.016)	0.0014 (0.014)
	3**	0.0016 (0.016)	0.0016 (0.016)	0.0015 (0.015)	0.0015 (0.015)	-
	4	0.0022 (0.022)	0.0022 (0.022)	0.0021 (0.021)	0.0019 (0.019)	0.0018 (0.018)

\* Maximum operating temperature 100 °C.

\*\* Maximum operating temperature 250 °C.



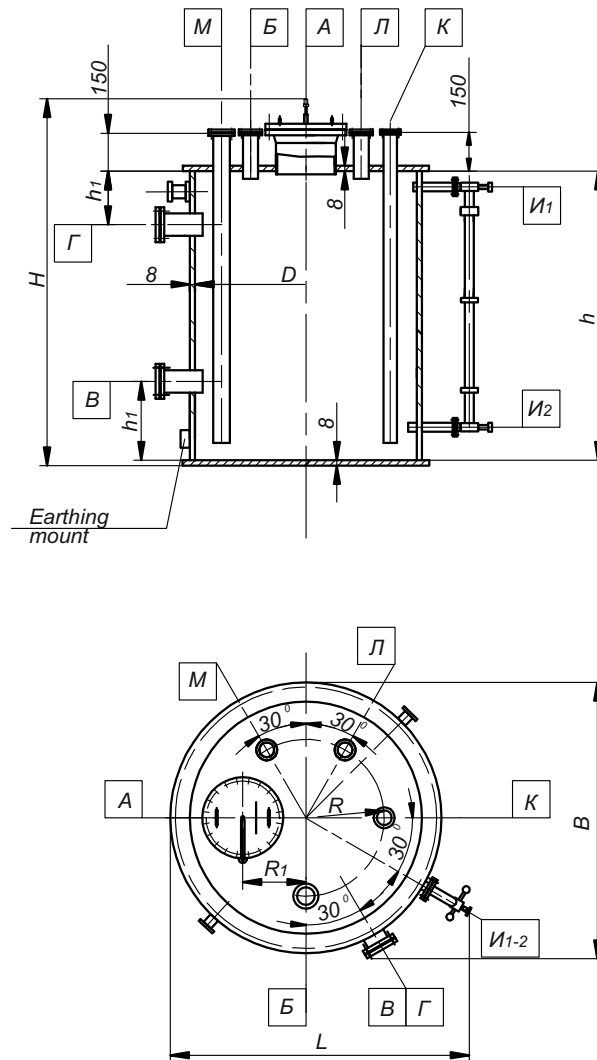

Fig. 1.14

Main dimensions of vessels, area of the heat exchanging surface

Table 1.54

Designation	Volume, m <sup>3</sup>		D	h	R	R <sub>1</sub>	h <sub>1</sub>
	Nominal	Operating					
VPP 1-4-10-0	10	8.4	2200	2500	800	600	150
VPP 1-4-16-0	16	15.5	2600	3200	950	750	
VPP 1-4-25-0	25	22.6	2800	4000	1000	850	

Development of design documentation and manufacture of vessels with the volume of more than 25 m<sup>3</sup> are carried out individually, according to the data sheet sent to our address by the Customer.



Main dimensions and weights of vessels

Table 1.55

Designation	Material make code	L	B	H	Weight, kg	
					Stainless steel parts	Total
VPP 1-1-10-0	1	2660	2365	2880	-	1930
	2			2900	1920	
	3					
	4					
VPP 1-1-16-0	1	2730	2740	3580	-	2700
	2			3600	2690	
	3					
	4					
VPP 1-1-25-0	1	2920	2925	4380	-	3380
	2			4400	3370	
	3					
	4					

Allowable operating pressure inside the vessel and allowable external pressure occurring  
due to the formation of vacuum in the vessel

Table 1.56

Designation	Material make code	Maximum allowed pressure, MPa (kgf/cm <sup>2</sup> )				
		At wall temperature value, °C				
		100	150	200	250	300
VPP1-1-10-0 VPP1-4-10-0	1	0.0022(0.022)	0.0022(0.022)	0.0021(0.021)	0.002(0.02)	0.0018(0.018)
	2	0.0027(0.027)	0.0026(0.026)	0.0025(0.025)	0.0024(0.024)	0.0022(0.022)
	3	0.0025(0.025)	0.0024(0.024)	0.0023(0.023)	0.0023(0.023)	0.0022(0.022)
	4	0.0035(0.035)	0.0033(0.033)	0.0032(0.032)	0.0029(0.029)	0.0028(0.028)
VPP1-1-16-0 VPP1-4-16-0	1	0.0017(0.017)	0.0016(0.016)	0.0015(0.015)	0.0015(0.015)	0.0013(0.013)
	2	0.002(0.02)	0.0019(0.019)	0.0018(0.018)	0.0018(0.018)	0.0017(0.017)
	3	0.0019(0.019)	0.0018(0.018)	0.0017(0.017)	0.0017(0.017)	0.0016(0.016)
	4	0.0026(0.026)	0.0025(0.025)	0.0024(0.024)	0.0021(0.021)	0.0021(0.021)
VPP1-1-25-0 VPP1-4-25-0	1	0.0014(0.014)	0.0014(0.014)	0.0013(0.013)	0.0013(0.013)	0.0011(0.011)
	2	0.0017(0.017)	0.0017(0.017)	0.0016(0.016)	0.0016(0.016)	0.0014(0.014)
	3	0.0016(0.016)	0.0016(0.016)	0.0015(0.015)	0.0015(0.015)	0.0014(0.014)
	4	0.0022(0.022)	0.0022(0.022)	0.0021(0.021)	0.0019(0.019)	0.0018(0.018)



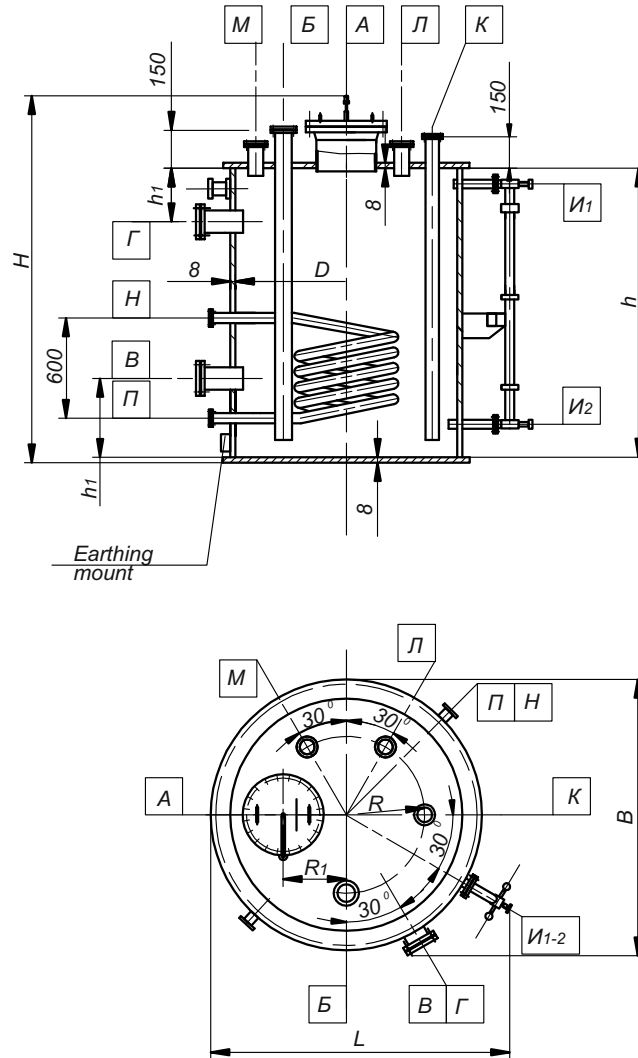

Fig. 1.15

Main dimensions of vessels, area of the heat exchanging surface

Table 1.57

Designation	Volume, m <sup>3</sup>		D	h	R	R <sub>1</sub>	h <sub>1</sub>
	Nominal	Operating					
VPP 1-4-10-0	10	8.4	2200	2500	800	600	150
VPP 1-4-16-0	16	15.5	2600	3200	950	750	
VPP 1-4-25-0	25	22.6	2800	4000	1000	850	200

Development of design documentation and manufacture of vessels with the volume of more than 25 m<sup>3</sup> are carried out individually, according to the data sheet sent to our address by the Customer.



## Main dimensions and weights of vessels

Table 1.58

Designation	Material make code	L	B	H	Weight, kg	
					Stainless steel parts	Total
VPP1-4-10-0	1	2660	2365	2880	-	2010
	2			2900	2000	
	3					
	4					
VPP1-4-16-0	1	2730	2740	3580	-	2800
	2			3600	2790	
	3					
	4					
VPP1-4-25-0	1	2920	2925	4380	-	3470
	2			4400	3460	
	3					
	4					



# 63 Data Sheet for Vessel Order

DATA SHEET No. \_\_\_\_\_

Vessel designation \_\_\_\_\_

Quantity \_\_\_\_\_

No.	Required data		In the vessel							In the heat exchanging element	
1	Medium characteristics	Name									
		Physical state (gas, vapor, liquid)									
		Composition, concentration, %									
		Crystallizing tendency									
		Explosion hazard per GOST 12.1.004-76									
		Hazard class per GOST 12.1.007-76									
2	Design parameters of process	Pressure, MPa (kgf/cm <sup>2</sup> ), design									
		Temperature, °C, design									
3	Material	of vessel shell									
		of parts contacting with the medium (tube bundle etc.)									
		of parts not contacting with the medium (jacket etc.)									
4	Supports type	concrete, metal on foundation, metal on metal structure (for horizontal vessels)									
		legs, lugs (for vertical vessels)									
5	Flange connections facing type (smooth, male-female)	of flanges contacting with the medium									
		of flanges contacting with the heat transfer agent									
6	Heat insulation presence and the need to weld parts for its fastening										
7	The need to weld strips for platforms and ladders (for vessels operating under the pressure of more than 0,07 MPa (0,7 kgf/cm <sup>2</sup> ))										
8	The need to install nozzles out of the ones listed in the catalogue for this vessel type (yes, no)		Г	Д	Е	Ж	И	К	Л	М (M <sub>1</sub> )	M <sub>2</sub>
9	The need to supply a switch-type level										
10	The need for intercrystal corrosion testing per the AM(AMU) method, GOST 6032										
11	Average temperature of the coldest five-days period, °C										
12	Installation location (outdoors, indoors with heating, indoors without heating)										
13	Minimum possible vessel wall temperature under operating conditions, °C										
14	Name, post index, post and telephone address, telephone of organization that has filled out the data sheet										

\_\_\_\_\_ (position)

\_\_\_\_\_ (signature)

\_\_\_\_\_ (name)

\_\_\_\_\_ (filling-out date)





# Vertical Steel Welded Vessels with Agitators

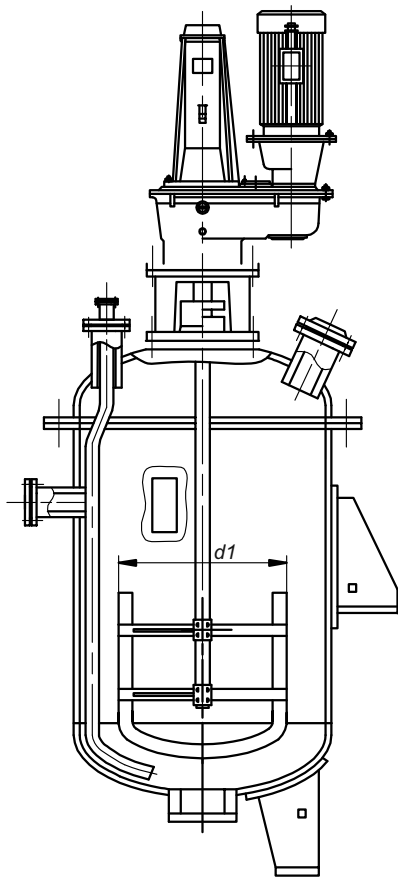

### Introduction

The catalogue contains the types, purpose, basic parameters, overall and connection dimensions of vertical vessels with agitators, as well as recommendations for their use.

The catalogue includes the description of steel welded vessels with a volume from 1 to 50 m<sup>3</sup>, operating at excessive pressure up to 6 kgf/cm<sup>2</sup>, as well as vessels operating at ambient pressure. The mentioned vessels are not applicable for lining, rubber coating and application of different protective coatings, except for the paint-and-lacquer coatings.

To order vessel it is required to complete the data sheet (refer to Appendix).

Vessel index for ordering consists of designation of casing design according to GOST 20680 (the first two

digits), designation of agitator and internals as per GOST 20680 (the next two digits), nominal volume of vessel (m<sup>3</sup>), nominal pressure in casing (MPa), codes of shaft seals, drive electric motor design and casing material (codes are indicated in table 2 and in catalogue text).

Example: 0023-5.0,6-TV31; 1110-25.0,3-SA62.

For vessel with two-stage agitator the number of agitator is indicated after designation of agitator and internals.

Example: 1123.2-25.0,3-SA62.

Design and main parameters are given in table 2.1.

For designation of agitator and internals, refer to table 2.7.

### General

Vertical vessels with agitators for different technological processes in liquid single-phase and multiphase media, with a dynamic viscosity up to 50 poise (5 pas), density up to 2000 kg/m<sup>3</sup>.

Operating environment in vessel casing - neutral, aggressive, combustible, explosive or toxic liquid, emulsion, liquid-gas mixture or suspension with solids mass concentration not more than 30%.

In the jacket and the coil – tap or circulating water, salt water, condensate, rich water steam or high-temperature organic heat transfer agent with the temperature between minus 30°C and plus 250°C and higher.

The choice of vessel should be carried out based on the technological process calculations (homogenization, suspending, emulsification, heat exchange etc.) per RD 26-01-90-85 or based on the results of experimental research of process on the model apparatus and the calculation of scaling from the model vessel to the actual one.

The types, main parameters and dimensions of vessels – per GOST 20680. The drive power capacity and the agitator rotation speed are specified in Table 2.8. Technical requirements to materials, fabrication, acceptance, test and preservation methods of the vessels – per OST 26-01-1244, GOST R 52630 and technical specifications of the manufacturing factory approved according to the established procedure.

Climatic make of vessels – U2 per GOST 15150, but for operation at the temperature not lower than minus 30°C.

At the ambient temperature lower than 0°C, it is necessary to make provisions to avoid freezing of the cooling and the feeding liquids in the shaft seal.

Per the customer requirement specified in the data sheet, it is possible to supply vessels of climatic make T2 per GOST 15150.

It is allowed to install vessels in areas with seismicity of maximum 8 on the Richter scale, if the vessel will be fixed to a foundation.

Steels used for shells fabrication and temperature limits of their application are given in Table 2.2.

At the discretion of the manufacturing factory, steel grade can be changed in accordance with the data of Table 2.2, if such substitution does not conflict with the normative technical documentation in effect.

Agitator, shaft and other parts contacting with the operating fluid are manufactured of steels with the corrosion strength value not lower than this value of steel used for the vessel shell manufacture.

Smooth welded jackets are manufactured of carbon steel. Steel grade is chosen from the ones listed in Table 2.2 with regard to the requirements of GOST R 52630, SOU MPP 71.120-217:2009.



Table 2.1

Shell make	Vessel name	Agitator and internals designation				Nominal volume, m <sup>3</sup>												Nominal gauge pressure in the shell	
		03	23	33	10	1	2	3,2	5	6,3	10	16	25	32	50	100	200	kgf/cm <sup>2</sup>	MPa
00	Vessels with elliptic head and detachable elliptic cover	+	+	+	+	+	+	+	+	+	+	+	+	+	+	+	+	6	0.6
01	Vessels with elliptic bottom heads and detachable elliptic cover, with smooth welded jacket	+	+	+	+	+	+	+	+	+	+	+	+	+	+	+	+		
10	All-welded vessels with elliptic head and cover	+	+	+	+	+	+	+	+	+	+	+	+	+	+	+	+	3; 6	0.3; 0.6
11	All-welded vessels with elliptic head and elliptic cover, with smooth welded jacket	+	+	+	+	+	+	+	+	+	+	+	+	+	+	+	+	6	0.6
12	All-welded vessels with elliptic head and cover, with half-piped jacket	+	+	+	+	+	+	+	+	+	+	+	+	+	+	+	+		
80	Vessels with flat head and detachable flat (spherical) cover	+	+	+	+	+	+	+	+	+	+	+	+	+	+	+	+	0	0
90	All-welded vessels with flat head and flat (spherical) cover	+	+	+	+	+	+	+	+	+	+	+	+	+	+	+	+		



## 67 Vertical Steel Welded Vessels with Agitators

Half-piped jackets are made of steel of the same grade as the vessel shell.

Project organization choosing the vessel determines the steel grade in accordance with specific operation conditions based on the current normative technical documentation.

Allowable one-sided corrosion – maximum 0.1 mm/year.

It is allowed to use vessels subjected to heat treatment for fluids causing corrosion cracking, if their strength is verified by strength calculations.

Heat treatment of vessels in this catalogue is carried out based on the operation conditions.

Vessel shells - per GOST9931. When choosing shell make, the following recommendations should be considered:

- for works under atmospheric pressure, it is preferred to use shells with flat (spherical) heads of 80 and 90 makes;
- shells with jackets of 01, 11 and 12 makes shall only be used in technically justified cases, if other shell makes cannot be used.

In cases condensate is allowed to get into the operating fluid, its heating can be done in vessels without heat exchanging devices via sharp steam feed.

Maximum operating gauge pressure in the vessel shell, depending on design wall temperature and operating

fluid properties, shall not exceed the values stated in Table 2.3.

Group A products – non-toxic, non-explosive and non-fire hazardous.

Group B products – toxic, explosive and fire hazardous.

Vessels with shells of all makes, except for 80 and 90, are allowed for use under vacuum.

Maximum residual pressure in the shell shall be the value considered with regard to the allowable external pressure specified in Table 2.4, but not lower than 20 mm Hg.

In vessels with shell makes 80 and 90, gauge pressure above the liquid surface in all operating cases shall not exceed 0,1 kgf/cm<sup>2</sup>.

The speed of temperature change of the shell and other parts of the vessel in all operating cases shall not exceed 30 °C/hour.

*Jackets.* Vessels with shell makes 01 and 11 are furnished with smooth welded jackets per OST 26-01-984. Vessels with shell make 12 – with half-piped jackets (per OST 26-01-987) on the cylindrical part of the shell. An external coil made of a cross-section pipe is welded to the elliptic head of these vessels.

Table 2.2

Material code	Shell material		Possible substitutions of shell materials		Wall temperature, °C
	Grade	GOST	Grade	GOST	
10	Ст3сп4	GOST 380	20K	GOST 1050	from minus 20 to + 200
20	09Г2С	GOST 5520	16ГС	GOST 5520	from minus 30 to + 200
30 31 32 40 41	12X18H10T* 10X17H13M2T* 10X17H13M3T* 08X22H6T* 08X21H6M2T*	GOST 5632	-	-	from minus 30 to + 250
42	08X18Г8H2T*				

\* Steels per the technical requirements of GOST 7350.



Operating gauge pressure in smooth welded jackets - maximum 4 kgf/cm<sup>2</sup>; in a half-piped jacket and external coil on the head – maximum 16 kgf/cm<sup>2</sup>.

Coils. Coils can be provided for vessels with shell makes 00, 10, 80 and 90.

Design and main dimensions of coils – per the effective industry standard. Operating gauge pressure in coil – maximum 16 kgf/cm<sup>2</sup>.

Supports. Vessels with shell makes 00, 01, 10 and 11 are manufactured with lug supports (normal for vessels without heat insulation and extended – for vessels with heat insulation) or with leg supports per ATK24.200.03. Vessels with shell make 12 – with cylindrical supports (per ATK24.200.04); vessels with shell makes 80 and 90 – with ring-type supports per the manufacturing factory's documentation according to the dimensions specified in this catalogue.

Vessels with flat heads shall be installed on mat foundation.

Per the customer requirement specified in the data sheet, vessels can be supplied with welded-on parts for heat insulation fastening per GOST 17314, and also with strips, welded to the outer shell, used for fastening external ladders and maintenance platforms.

Allowable load on the maintenance platform - maximum 200 kgf.

Slinging devices of vessels – per GOST 13716. Trunnions location on the vessel – per the manufacturing factory's documentation. Trunnions can be installed on the external shell, on the vessel's cover, as well as on the drive stand. Trunnion axis location is specified on fig. 2.1-2.7.

Nozzles. Vessels have process nozzles, as well as nozzles for instrumentation and safety devices. All-welded vessels have manholes for examination, cleaning and repairs.

Nominal pressure of flanges: in shells of 00, 01 makes and manholes – is considered equal to the nominal pressure in the shell, but no less than 3 kgf/cm<sup>2</sup>; in half-piped jacket, external and internal coils - 16 kgf/cm<sup>2</sup>; other nozzles - 10 kgf/cm<sup>2</sup>.

Flange facings of vessels furnished with packing glands, - "smooth"; of vessels with end seals – "male-female".

Vessels are supplied with counter-flanges.

Per the customer requirement specified in the data sheet, vessels with shell makes 00, 01, 10 and 12 can be supplied with a calm down pipe.

Changes to the nozzles' location and diameter is allowed per agreement with the vessel's developer.

Location and connection dimensions of nozzles are given in fig. 2.1-2.7 and Tables 2.10-2.16.

Nozzles service for all vessels is given in Table 2.5.

Nominal diameters of nozzles, depending on the cover type and the shell diameter, are given in Table 2.6.

Nozzles stand-outs (distance from the flange slot plane to the external shell's outer plane, cover, measured along the nozzle's axis), aside from the ones stated in fig. 2.1-2.7 and Tables 2.10-2.16, are considered to be 200 mm.

Vessel gaskets – made of paronite or any other sealing material (rubber, PTFE or gaskets of fluoroplastic tape, spiral wound, Frenzelit type etc.).

Agitators. Vessels are furnished with turbine open and gate agitators.

Vessels with deflective baffles with the volume of 25, 32 and 50 m<sup>3</sup> are furnished with two turbine open agitators, the distance between which height-wise is 2000 mm. Fig. 2.3, 2.4, 2.5 and 2.7 do not show a sketch of a double-deck agitator.

Maximum operating gauge pressure in the vessel shell

Table 2.3

Nominal gauge pressure in the shell, kgf/cm <sup>2</sup>	Design wall temperature, °C							
	Up to 100		Between 100 and 150		Between 150 and 200		Between 200 and 250	
	Allowable operating gauge pressure (kgf/cm <sup>2</sup> ) for operation groups							
	A	Б	A	Б	A	Б	A	Б
3	3	2.7	2.7	2.4	2.6	2.3	2.5	2.2
6	6	5.4	5.4	4.8	5.2	4.6	5	4.4



Allowable external pressure, kgf/cm<sup>2</sup>

Table 2.4

Shell make	Nominal gauge pressure in the shell, kgf/cm <sup>2</sup>	Vessel volume, m <sup>3</sup>									
		1	2	3,2	5	6,3	10	16	25	32	50
00	6	0.97	0.85	0.59	0.41	0.33	-	-	-	-	-
01	6	4.24	5.23	5.76	5.88	4.25	-	-	-	-	-
10	3	-	-	-	-	-	-	0.36	0.25	0.2	0.13
10	6	-	-	-	-	-	0.53	0.36	0.46	0.38	0.25
11	6	-	-	-	-	-	4.23	5	4.4	4.6	4.2
12	6	-	-	-	-	-	0.97	0.89	0.6	0.48	0.32
80	0	0.1	0.1	0.1	0.1	0.1	-	-	-	-	-
90	0	-	-	-	-	-	0.1	0.1	0.1	0.1	-

Nozzles service

Table 2.5

Nozzle designation	Service
A	For product inlet
Б	Process
B	Process
Г	For safety valve
Д	For calm down pipe
Е	Stand-by
Ж	For manometer
И	For thermometer
K, K <sub>1</sub>	For heat-transferring fluid inlet and outlet
Л	Manhole
M, M <sub>1</sub> , M <sub>2</sub>	For heat-transferring fluid inlet and outlet
H, H <sub>1</sub>	For heat-transferring fluid inlet and outlet
H <sub>2</sub> , H <sub>3</sub>	For heat-transferring fluid inlet and outlet
О	For product outlet
П	For product pour-over

Recommendations on the use of agitators depending on the shell make and the vessel's service are given in Table 2.7. Each of the processes listed in Table 2.7 can be accompanied by mass transfer and chemical reaction.

It is preferred to use an agitator with minimal drive power capacity.

Design and main dimensions of agitators – per ATK 24.201.17.

**Drives.** Vessels are furnished with motor reducers of RC80 and RC130 types per the “Sumy NPO” JSC nomenclature, with electric motors of the general industrial or explosion-proof make (electric motor make is specified by the customer).

Furnished motor reducers for vessels with shells of all makes depending on the vessel volume and agitator make are given in Table 2.8. Table 2.9 lists the main characteristics of furnished motor reducers.



Nominal diameters of nozzles

Table 2.6

Shell diameter D, mm	Nominal diameter of nozzles, mm													
	А	Б	В	Г	Д	Е	Ж	И	К, К <sub>1</sub>	Л	М, М <sub>1</sub> , М <sub>2</sub>	Н, Н <sub>1</sub>	Н <sub>2</sub> , Н <sub>3</sub>	О, П
<b>For vessels with elliptic covers</b>														
1000	100	8	80	80	50/80	-		100	50	150	50	-	-	100
1400	150	100	100	100	65/100	50		100	50	250	50	-	-	100
1600	200	100	100	100	100/150	50		150	50	250	50	-	-	100
1800	200	100	100	100	100/150	50		150	50	250	50	-	-	100
2200	200	100	100	150	125/200	50	50	200	80	500	50	80	25	150
2400	250	200	200	150	125/200	100		200	80	500	80	80	25	150
2800	250	200	200	200	150/250	100		250	80	700	80	80	25	200
3000	250	200	200	200	150/250	100		250	80	700	80	80	25	200
<b>For vessels with flat covers</b>														
1000	100	80				50			50	150				100
1400	150	100				50			50	250				100
1600	200	150				50			50	250				100
1800	200	150		100	100	50	50	-	50	250				100
2200	200	150	-	100	100	50	50	-	80	500	-	-	-	150
2400	250	200				100			80	500				150
2800	250	200				100			80	700				200
3000	250	200				100			80	700				200

Choice of agitators depending on the shell make

Table 2.7

Agitator type	Vessel internals	Agitator and internals designation	Vessel shell make	Process in the vessel						Dynamic viscosity of operating medium, Па
				Homogenization, mixing of mutually solvable liquids	Suspending, dissolving of solids with density higher than the density of liquid	Suspending, dissolving of solids with density lower than the density of liquid	Emulsification, mixing of mutually non-solvable liquids	Gas-in-liquid dispersion	Heat exchange (heating or cooling)	
turbine open	without internals	03	00, 10, 80, 90	+	+	—	—	—	—	Lower than 5
			01, 11, 12	+	+	—	—	—	(+)	
	deflecting baffles	23	00, 10, 80, 90	—	(+)	+	+	+	—	
			01, 11, 12	—	(+)	+	+	+	(+)	
coil	33	00, 10, 80, 90	+	+	—	—	—	+		
gate	without internals	10	01, 11, 12	(+)	—	—	—	—	(+)	5-50
			00, 10	+	+	+	—	—	—	

**Note.** The (+) mark means that it is allowed to use the agitator, if, according to the calculations, the process cannot be carried out with an agitator of 03 or 33 make.



Motor reducer choice based on the shell volume

Table 2.8

Nominal vessel volume, m <sup>3</sup>	Motor reducer designation for vessels with agitators and internal actuating devices		
	03 and 33	23	10
1	RC80/2-3.0-170	RC80/2-3.0-170	RC80/3-5.5-45
2	RC80/2-3.0-170	RC80/2-5.5-130	RC80/3-5.5-45
3.2	RC80/2-3.0-170	RC80/2-5.5-130	RC80/3-5.5-45
5	RC80/2-3.0-170	RC80/2-15-125	RC80/3-5.5-45
6.3	RC80/2-5.5-130	RC80/2-15-125	RC80/3-7.5-45
10	RC80/2-5.5-130	RC130/3-22-32; RC130/2-18.5-63	RC130/3-15-32
16	RC80/2-15-125	RC130/3-22-32; RC130/2-18.5-63	RC130/3-15-32
25	RC130/2-18.5-63	*	RC130/3-18.5-20
32	RC130/2-18.5-63	*	RC130/3-18.5-20
50	RC130/2-18.5-63	*	RC130/3-18.5-20

\* - design documentation development and manufacture of motor reducers with the capacity over 30 kW are carried out individually, as per the data sheet submitted to our address by the Customer.

Note. The numbers in the motor reducer designation mean:

-... - drive capacity (kW),

-... - outlet shaft rotation speed (rpm).

For example: RC80/2-3.0-170

where: 3.0 - drive capacity (kW), 170 - outlet shaft rotation speed (rpm).

Seals. Vessels are manufactured with packing glands of the 1UB type per OST 26-01-1247 or with end seals of the TMD type (for vessels with volume of 3,2m<sup>3</sup> and more) per ATK 24.201.13.

Seal type code in the vessel designation: S - packing; T - end.

Packing glands are used in vessels used in non-toxic, non-highly volatile and non-explosive services, with media operating under atmospheric pressure, gauge pressure up to 6 kg/cm<sup>2</sup> or in vacuum with residual pressure of at least 300 mm Hg. Packing glands are allowed for toxic fluids, if the toxic substances concentration in rich vapors above the liquid surface inside the vessel under operating conditions does not exceed the maximum allowable concentration (MAC) for the working zone per the sanitary norms in effect.

End seals are used in vessels in toxic, flammable and explosive services regardless of pressure in the vessel, as well as in vessels operating under vacuum pressure with the residual pressure of less than 300 Hg mm, regardless of the operating fluid properties.

The choice of the seal type, depending on the operating fluid properties and pressure in the vessel, is done by the project organization that chooses the vessel.

When using vessels in outdoors packages, shaft seal protection from climatic factors needs to be applied.

To remove and install end seals, partial disassembly of the drive is carried out in accordance with the installation and operation manual included in the scope of supply.

The supply package is as per SOU MPP 71.120-217:2009, GOST R 52630 and CU TR 032/2013. The assembled vessel, with counter-flanges and gaskets of paronite or others per the agreement with the customer.

Motor reducer and end seal are supplied separately from the vessel, in an individual packaging with regulating (forcing) screw, base plates, mounting devices, spare parts and accompanying documentation.

To prevent damage during transportation, the shaft and agitators are unfastened inside the vessel.

Instrumentation devices, valves, safety devices and the thermometer tube are not included in the supply package.





Technical characteristics of motor reducers

Table 2.9

Designation	Name	Power transferred by the reducer, kW	Torque on the outlet shaft, Nm	Outlet shaft rotation speed, rpm	Reduction ratio	Weight, kg
1.5000-2379.00-00	RC80/2-3.0-170	3.0	170	170	8.0	328
1.5000-2376.00-00	RC80/2-5.5-130	5.5	405	130	11	328
S300.274	RC80/3-5.5-63	5.5	1670	32	45	326
S300.274-01	RC80/3-5.5-125	5.5	1190	45	32	326
1.5000-2384.00-00	RC80/3-7.5-125	7.5	1590	45	32	328
S300.270	RC80/2-11-63	11	1690	63	23	330
S300.270-01	RC80/2-15-125	15	1150	125	12	328
1.5000-2375.00-00	RC80/2-15-125	15	1150	125	12	328
1.5000-2377.00-00	RC130/3-15-32	15	4485	32	45	960
S300.282-01	RC130/3-15-32	15	4550	32	45	967
1.5000-2383.00-00	RC130/3-18.5-20	18.5	8840	20	72	967
1.5000-2355.00-00	RC130/2-18.5-63	18.5	2810	63	23	990
S300.282	RC130/3-18.5-250	18.5	7171	25	58.8	965
S300.282-02	RC130/3-22-32	22	6680	32	45	955
S300.278	RC130/2-30-63	30	4610	63	23	990
S300.278-01	RC130/2-30-250	30	1160	250	6.0	980



# 73 Vessels with Elliptic Bottom Heads and Detachable Elliptic Cover

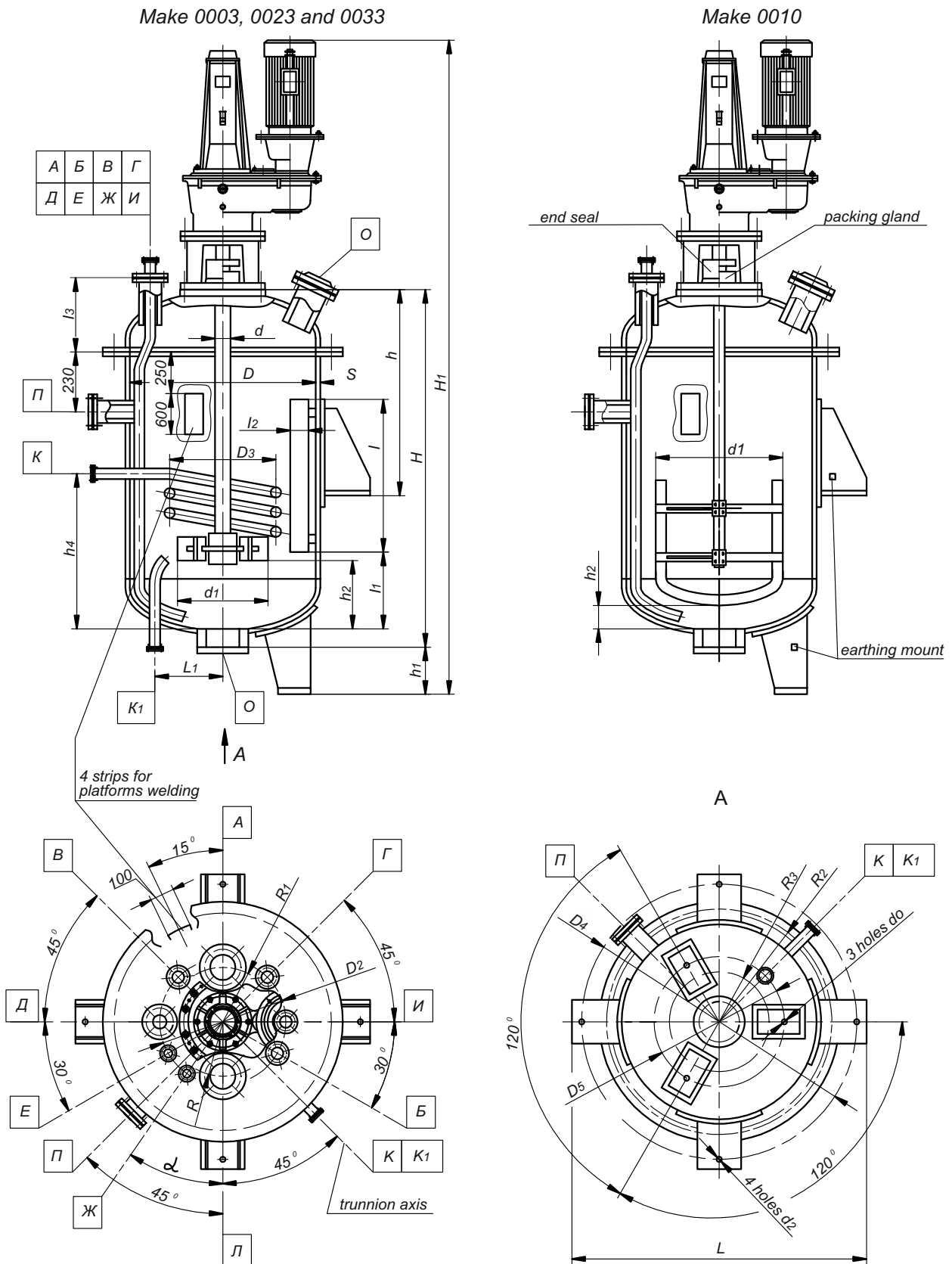

Fig.2.1



Main dimensions and weights of vessels

Table 2.10

Vessel make	mm																		
	D	D <sub>2</sub>	D <sub>3</sub>	D <sub>5</sub>	d	d <sub>1</sub>	d <sub>2</sub>	H	H <sub>1</sub>	h	h <sub>1</sub>	h <sub>2</sub>	h <sub>4</sub>	L <sub>1</sub>	l	l <sub>1</sub>	l <sub>2</sub>	l <sub>3</sub>	
0003-1.0,6	1000	660	-	920	50	360	24	1515	3175*	920	215	390	-	-	-	-	-	-	450
0023-1.0,6	1000	660	-	920	50	360	24	1515	3175*	920	215	390	-	-	900	250	100	-	450
0033-1.0,6	1000	660	740	920	50	360	24	1515	3175*	920	215	390	700	300	-	-	-	-	450
0010-1.0,6	1000	660	-	920	50	800	24	1515	3252*	920	215	100	-	-	-	-	-	-	450
0003-2.0,6	1400	940	-	1260	50	400	24	1615	3225*	1110	165	370	-	-	-	-	-	-	520
0023-2.0,6	1400	940	-	1260	50	400	24	1615	3225*	1110	165	370	-	-	800	350	140	-	520
0033-2.0,6	1400	940	1060	1260	50	400	24	1615	3225*	1110	165	370	890	430	-	-	-	-	520
0010-2.0,6	1400	940	-	1260	50	1060	24	1615	3302*	1110	165	170	-	-	-	-	-	-	520
0003-3,2,0,6	1600	1050	-	1410	65	450	35	1915	3575*	1255	215	450	-	-	-	-	-	-	565
0023-3,2,0,6	1600	1050	-	1410	66	450	35	1915	3575*	1255	215	450	-	-	1000	400	160	-	565
0033-3,2,0,6	1600	1050	1220	1410	65	450	35	1915	3575*	1255	215	450	1030	510	-	-	-	-	565
0010-3,2,0,6	1600	1050	-	1410	65	1320	35	1915	3652*	1255	215	140	-	-	-	-	-	-	565
0003-5.0,6	1800	1200	-	1610	65	630	35	2295	3985*	1305	245	430	-	-	-	-	-	-	600
0023-5.0,6	1800	1200	-	1610	65	630	35	2295	4165*	1305	245	430	-	-	1250	450	180	-	600
0033-5.0,6	1800	1200	1380	1610	65	630	35	2295	3985*	1305	245	430	1080	590	-	-	-	-	600
0010-5.0,6	1800	1200	-	1610	65	1500	35	2295	4062*	1305	245	150	-	-	-	-	-	-	600
0003-6,3,0,6	1800	1200	-	1610	65	630	35	2845	4535*	1480	245	540	-	-	-	-	-	-	600
0023-6,3,0,6	1800	1200	-	1610	65	630	35	2845	4715*	1480	245	540	-	-	1800	450	180	-	600
0033-6,3,0,6	1800	1200	1380	1610	65	630	35	2845	4535*	1480	245	540	1080	590	-	-	-	-	600
0010-6,3,0,6	1800	1200	-	1610	65	1500	35	2845	4612*	1480	245	150	-	-	-	-	-	-	600



Table 2.10 (cont.)

Vessel make	R	R <sub>1</sub>	R <sub>3</sub>	$\alpha$ , degree	S	Lug supports						Coil		Weight, kg		
						normal			extended			No. of passes	Heat exchanging surface, m <sup>2</sup>	Total	including nickel-containing steel	
						D <sub>4</sub>	L	R <sub>2</sub>	D <sub>4</sub>	L	R <sub>2</sub>					
0003-1.0,6	320	330	402	45	6	1298	1342	591	1498	1542	691	-	-	780 *	540 *	
0023-1.0,6	320	330	402	45	6	1298	1342	591	1498	1542	691	-	-	805 *	565 *	
0033-1.0,6	320	330	402	45	6	1298	1342	591	1498	1542	691	5	2.3	845 *	605 *	
0010-1.0,6	320	330	402	45	6	1298	1342	591	1498	1542	691	-	-	790 *	550 *	
0003-2.0,6	400	450	572	40	6	1698	1742	791	1898	1942	891	-	-	1155 *	885 *	
0023-2.0,6	400	450	572	40	6	1698	1742	791	1898	1942	891	-	-	1185 *	915 *	
0033-2.0,6	400	450	572	40	6	698	1742	791	1898	1942	891	6	3.3	1255 *	985 *	
0010-2.0,6	400	450	572	40	6	1698	1742	791	1898	1942	891	-	-	1175 *	905 *	
0003-3.2,0,6	425	500	645	40	6	1922	2002	901	2182	2262	1031	-	-	1640 *	1190 *	
0023-3.2,0,6	425	500	645	40	6	1922	2002	901	2182	2262	1031	-	-	1680 *	1230 *	
0033-3.2,0,6	425	500	645	40	6	1922	2002	901	2182	2262	1031	7	4.9	1775 *	1325 *	
0010-3.2,0,6	425	500	645	40	6	1922	2002	901	2182	2262	1031	-	-	2040 *	1240 *	
0003-5.0,6	540	580	725	40	8	2220	2300	1030	2520	2600	1180	-	-	2280 *	1830 *	
0023-5.0,6	540	580	725	40	8	2220	2300	1030	2520	2600	1180	-	-	2690 *	1890 *	
0033-5.0,6	540	580	725	40	8	2220	2300	1030	2520	2600	1180	7	5.5	2430 *	1980 *	
0010-5.0,6	540	580	725	40	8	2220	2300	1030	2520	2600	1180	-	-	2680 *	1880 *	
0003-6.3,0,6	540	580	725	40	8	2220	2300	1030	2520	2600	1180	-	-	3060 *	2080 *	
0023-6.3,0,6	540	580	725	40	8	2220	2300	1030	2520	2600	1180	-	-	3145 *	2165 *	
0033-6.3,0,6	540	580	725	40	8	2220	2300	1030	2520	2600	1180	7	5.5	3210 *	2230 *	
0010-6.3,0,6	540	580	725	40	8	2220	2300	1030	2520	2600	1180	-	-	3110 *	2130 *	

Note: \* Clarified during designing



Make 0103, 0123

Make 0110

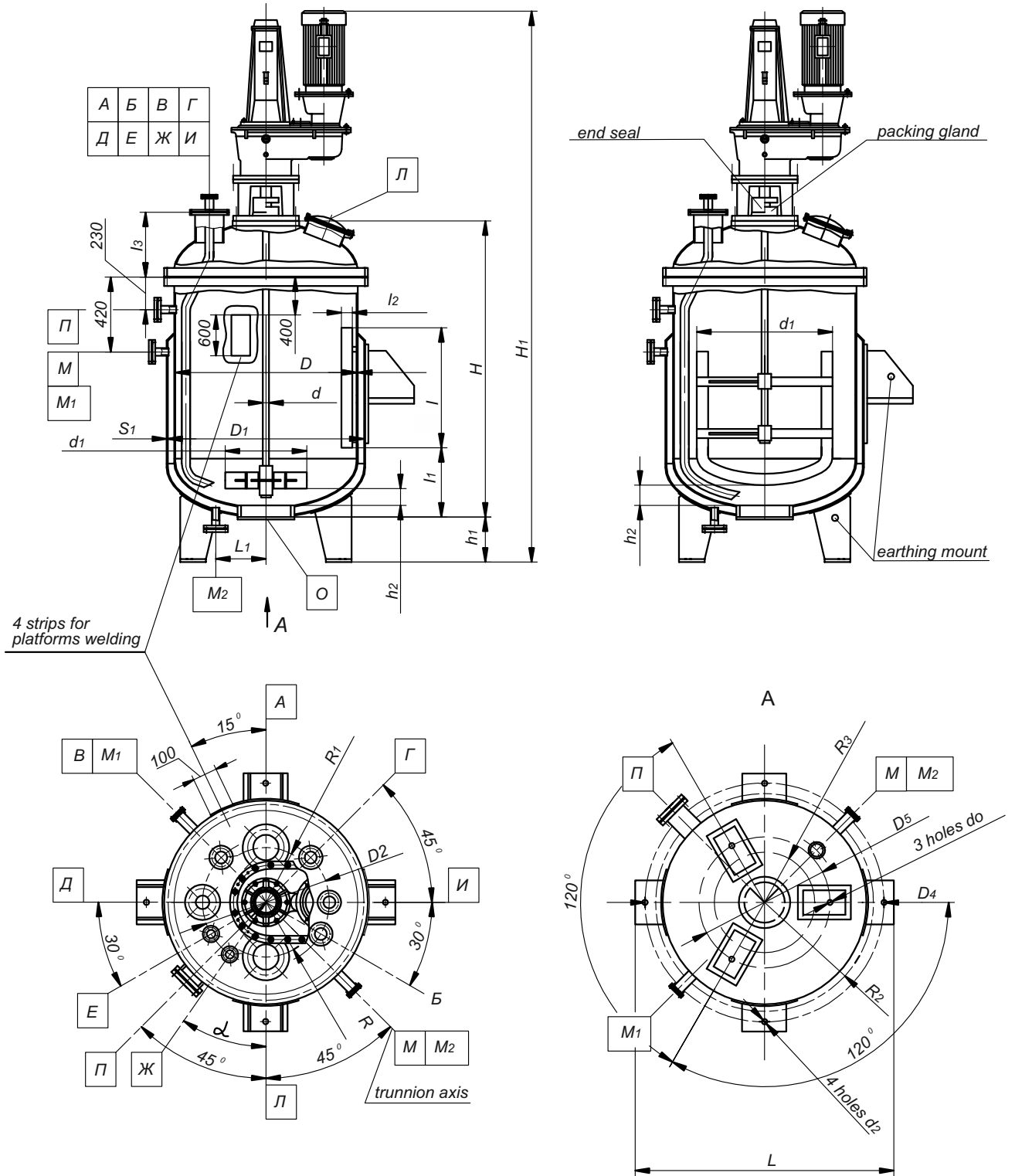

Fig.2.2



Main dimensions and weights of units

Table 2.11

Vessel make	mm																
	D	D <sub>1</sub>	D <sub>2</sub>	D <sub>5</sub>	d	d <sub>1</sub>	d <sub>2</sub>	H	H <sub>1</sub>	h	h <sub>1</sub>	h <sub>2</sub>	L <sub>1</sub>	l	l <sub>1</sub>	l <sub>2</sub>	l <sub>3</sub>
0103-1.0,6	1000	1100	660	1000	50	360	24	1515	3195 *	1160	235	390	200	-	-	-	450
0123-1.0,6	1000	1100	660	1000	50	360	24	1515	3195 *	1160	235	390	200	900	250	100	450
0110-1.0,6	1000	1100	660	1000	50	800	24	1515	3272 *	1160	235	100	200	-	-	-	450
0103-2.0,6	1400	1500	940	1360	50	400	24	1615	3215 *	1360	155	37	250	-	-	-	520
0123-2.0,6	1400	1500	940	1360	50	400	24	1615	3215 *	1360	155	370	250	800	350	140	520
0110-2.0,6	1400	1500	940	1360	50	1060	24	1615	3292 *	1360	155	170	250	-	-	-	520
0103-3.2.0,6	1600	1700	1050	1510	65	450	35	1915	3575 *	1505	215	450	250	-	-	-	565
0123-3.2.0,6	1600	1700	1050	1510	65	450	35	1915	3575 *	1505	215	450	250	1000	400	160	565
0110-3.2.0,6	1600	1700	1050	1510	65	1320	35	1915	3652 *	1505	215	140	250	-	-	-	565
0103-5.0,6	1800	1900	1200	1700	65	630	35	2295	3995 *	1565	255	430	250	-	-	-	600
0123-5.0,6	1800	1900	1200	1700	65	630	35	2295	3995 *	1565	255	430	250	1250	450	180	600
0110-5.0,6	1800	1900	1200	1700	65	1500	35	2295	4072 *	1565	255	150	250	-	-	-	600
0103-6.3.0,6	1800	1900	1200	1700	65	630	35	2845	4545 *	1740	255	540	250	-	-	-	600
0123-6.3.0,6	1800	1900	1200	1700	65	630	35	2845	4545 *	1740	255	540	250	1800	450	1800	600
0110-6.3.0,6	1800	1900	1220	1700	65	1500	35	2845	4622 *	1740	255	150	250	-	-	-	600



Table 2.11 (cont.)

Vessel make	R	R <sub>1</sub>	R <sub>2</sub>	α, degree	S	S <sub>1</sub>	Lug supports								Heat exchanging surface, m <sup>2</sup>	Weight (max.), kg	
							normal				extended					Total	including nickel-containing steel
							D <sub>4</sub>	L	R <sub>2</sub>	D <sub>4</sub>	L	R <sub>2</sub>	D <sub>4</sub>	L			
mm																	
0103-1.0,6	320	330	442	45	8	6	1394	1438	639	1594	1638	739	2,9	1030 *	640 *		
0123-1.0,6	320	330	442	45	8	6	1394	1438	639	1594	1638	739	2,9	1055 *	665 *		
0110-1.0,6	320	330	442	45	8	6	1394	1438	639	1594	1638	739	2,9	1040 *	650 *		
0103-2.0,6	400	450	622	40	10	8	1822	1902	851	2082	2162	981	4,3	1770 *	1210 *		
0123-2.0,6	400	450	622	40	10	8	1822	1902	851	2082	2162	981	4,3	1800 *	1240 *		
0110-2.0,6	400	450	622	40	10	8	1822	1902	851	2082	2162	981	4,3	1790 *	1230 *		
0103-3.2.0,6	425	500	695	40	12	8	2012	2092	946	2312	2392	1096	6,2	2705 *	1845 *		
0123-3.2.0,6	425	500	695	40	12	8	2012	2092	946	2312	2392	1096	6,2	2745 *	1885 *		
0110-3.2.0,6	425	500	695	40	12	8	2012	2092	946	2312	2392	1096	6,2	3165 *	1895 *		
103-5.0,6	540	580	775	40	14	10	2216	2296	1028	2516	2596	1178	9	3890 *	2695 *		
0123-5.0,6	540	580	775	40	14	10	2216	2296	1028	2516	2596	1178	9	4300 *	2755 *		
0110-5.0,6	540	580	775	40	14	10	2216	2296	1028	2516	2596	1178	9	4290 *	2745 *		
0103-6.3.0,6	540	580	775	40	14	10	2376	2456	1068	2596	2676	1178	12,1	5120 *	3140 *		
0123-6.3.0,6	540	580	775	40	14	10	2376	2456	1068	2596	2676	1178	12,1	5205 *	3225 *		
0110-6.3.0,6	540	580	775	40	14	10	2376	2456	1068	2596	2676	1178	12,1	5170 *	3190 *		

Note: \* Clarified during designing



Make 1003, 1023 & 1033

Make 1010

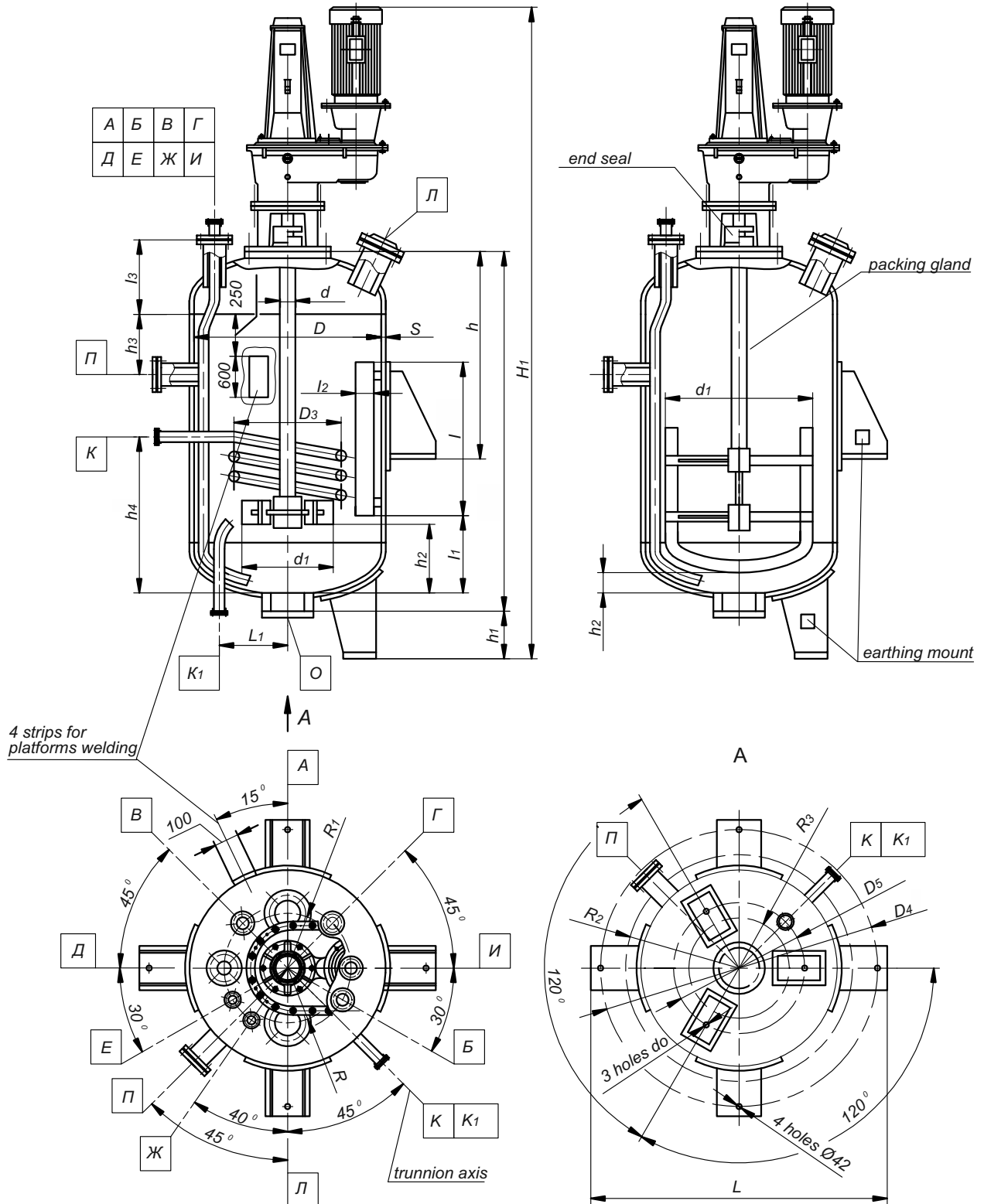

Fig.2.3





Main dimensions and weights of vessels

Table 2.12

Vessel make	D	D <sub>2</sub>	D <sub>3</sub>	D <sub>5</sub>	d	d <sub>r</sub>	H	H <sub>r</sub>	h	h <sub>r</sub>	h <sub>2</sub>	h <sub>3</sub>	h <sub>4</sub>	L <sub>1</sub>	l	l <sub>1</sub>	l <sub>2</sub>	l <sub>3</sub>
1003-10.0,6	2200	1450	-	2010	95	710	3055	4785 *	1650	285	630	120	-	-	-	-	-	685
1023-10.0,6	2200	1450	-	2010	95	710	3055	5365 *	1650	285	630	120	-	-	1600	550	220	685
1033-10.0,6	2200	1450	1670	2010	95	710	3055	4785 *	1650	285	630	120	1630	685	-	-	-	685
1010-10.0,6	2200	1450	-	2010	95	1800	3055	5365 *	1650	285	200	120	-	-	-	-	-	685
1003-16.0,6	2400	1600	-	2210	95	710	3955	6120 *	1710	475	730	120	-	-	-	-	-	720
1023-16.0,6	2400	1600	-	2210	95	710	3955	6455 *	1710	475	730	120	-	-	2400	600	240	720
1033-16.0,6	2400	1600	1830	2210	95	710	3955	6120 *	1710	475	730	120	1545	765	-	-	-	720
1010-16.0,6	2400	1600	-	2210	95	2000	3955	6455 *	1710	475	200	120	-	-	-	-	-	720
1003-25.0,3	2800	1800	-	2610	110	1250	4570	7340 *	2015	745	730	150	-	-	-	-	-	810
1003-25.0,6	2800	1800	-	2610	110	1250	4570	7340 *	2015	745	730	150	-	-	-	-	-	810
1023-2-25.0,3	2800	1800	-	2610	110	1250	4570	7340 *	2015	745	730	150	-	-	2600	700	280	810
1023-2-25.0,6	2800	1800	-	2610	110	1250	4570	7340 *	2015	745	730	150	-	-	2600	700	280	810
1033-25.0,3	2800	1800	2150	2610	110	1250	4570	7340 *	2015	745	730	150	1510	925	-	-	-	810
1033-25.0,6	2800	1800	2150	2610	110	1250	4570	7340 *	2015	745	730	150	1510	925	-	-	-	810
1010-25.0,3	2800	1800	-	2610	110	2360	4570	7340 *	2015	745	220	150	-	-	-	-	-	810
1010-25.0,6	2800	1800	-	2610	110	2360	4570	7340 *	2015	745	220	150	-	-	-	-	-	810
1003-32.0,3	3000	2000	-	2810	110	1250	5070	7790 *	2075	695	980	150	-	-	-	-	-	830
1003-32.0,6	3000	2000	-	2810	110	1250	5070	7790 *	2075	695	980	150	-	-	-	-	-	830
1023-2-32.0,3	3000	2000	-	2810	110	1250	5070	7790 *	2075	695	980	150	-	-	3000	750	300	830
1023-2-32.0,6	3000	2000	-	2810	110	1250	5070	7790 *	2075	695	980	150	-	-	3000	750	300	830
1033-32.0,3	3000	2000	2310	2810	110	1250	5070	7790 *	2075	695	980	150	1560	1005	-	-	-	830
1033-32.0,6	3000	2000	2310	2810	110	1250	5070	7790 *	2075	695	980	150	1560	1005	-	-	-	830
1010-32.0,3	3000	2000	-	2810	110	2500	5070	7790 *	2075	695	250	150	-	-	-	-	-	830
1010-32.0,6	3000	2000	-	2810	110	2500	5070	7790 *	2075	695	250	150	-	-	-	-	-	830
1003-50.0,3	3000	2000	-	2810	130	1250	7670	10400 *	2075	705	1280	150	-	-	-	-	-	830
1003-50.0,6	3000	2000	-	2810	130	1250	7670	10400 *	2075	705	1280	150	-	-	-	-	-	830
1023-2-50.0,3	3000	2000	-	2810	130	1250	7670	10400 *	2075	705	1280	150	-	-	3000	750	300	830
1023-2-50.0,6	3000	2000	-	2810	130	1250	7670	10400 *	2075	705	1280	150	-	-	3000	750	300	830
1033-50.0,3	3000	2000	2310	2810	130	1250	7670	10400 *	2075	705	1280	150	1560	1005	-	-	-	830
1033-50.0,6	3000	2000	2310	2810	130	1250	7670	10400 *	2075	705	1280	150	1560	1005	-	-	-	830
1010-50.0,3	3000	2000	-	2810	130	2500	7670	10400 *	2075	705	250	150	-	-	-	-	-	830
1010-50.0,6	3000	2000	-	2810	130	2500	7670	10400 *	2075	705	250	150	-	-	-	-	-	830



Table 2.12 (cont.)

Vessel make	R	R <sub>1</sub>	R <sub>3</sub>	S	Lug supports						Coil		Weight, kg		
					normal			extended			No. of laps	Heat exchanging surface, m <sup>2</sup>	Total	including nickel-steel	
					D <sub>4</sub>	L	R <sub>2</sub>	D <sub>4</sub>	L	R <sub>2</sub>					
mm															
1003-10.0,6	600	700	885	8	2780	2860	1270	3200	3280	1480	-	-	3615 *	2335 *	
1023-10.0,6	600	700	885	8	2780	2860	1270	3200	3280	1480	-	-	4160 *	2490 *	
1033-10.0,6	600	700	885	8	2780	2860	1270	3200	3280	1480	8	11,1	4070 *	2790 *	
1010-10.0,6	600	700	885	8	2780	2860	1270	3200	3280	1480	-	-	4130 *	2460 *	
1003-16.0,6	650	750	965	8	3108	3228	1414	3628	3748	1674	-	-	4365 *	3085 *	
1023-16.0,6	650	750	965	8	3108	3228	1414	3628	3748	1674	-	-	4995 *	3325 *	
1033-16.0,6	650	750	965	8	3108	3228	1414	3628	3748	1674	7	10,7	4795 *	3515 *	
1010-16.0,6	650	750	965	8	3108	3228	1414	3628	3748	1674	-	-	4925 *	3255 *	
1003-25.0,3	740	850	1125	8	3696	3816	1668	4336	4456	1988	-	-	6445 *	4275 *	
1003-25.0,6	740	850	1125	10	3696	3816	1668	4336	4456	1988	-	-	7260 *	5090 *	
1023-2-25.0,3	740	850	1125	8	3696	3816	1668	4336	4456	1988	-	-	8955 *	4655 *	
1023-2-25.0,6	740	850	1125	10	3696	3816	1668	4336	4456	1988	-	-	9770 *	5470 *	
1033-25.0,3	740	850	1125	8	3696	3816	1668	4336	4456	1988	6	10,7	6885 *	4715 *	
1033-25.0,6	740	850	1125	10	3696	3816	1668	4336	4456	1988	6	10,7	7700 *	5530 *	
1010-25.0,3	740	850	1125	8	3696	3816	1668	4336	4456	1988	-	-	8715 *	4415 *	
1010-25.0,6	740	850	1125	10	3696	3816	1668	4336	4456	1988	-	-	9530 *	5230 *	
1003-32.0,3	800	950	1225	8	3896	4016	1768	4536	4656	2088	-	-	7160 *	4990 *	
1003-32.0,6	800	950	1225	10	3896	4016	1768	4536	4656	2088	-	-	8230 *	6060 *	
1023-2-32.0,3	800	950	1225	8	3896	4016	1768	4536	4656	2088	-	-	9740 *	5440 *	
1023-2-32.0,6	800	950	1225	10	3896	4016	1768	4536	4656	2088	-	-	10810 *	6510 *	
1033-32.0,3	800	950	1225	8	3896	4016	1768	4536	4656	2088	6	11,5	7630 *	5460 *	
1033-32.0,6	800	950	1225	10	3896	4016	1768	4536	4656	2088	6	11,5	8700 *	6530 *	
1010-32.0,3	800	950	1225	8	3896	4016	1768	4536	4656	2088	-	-	9520 *	5220 *	
1010-32.0,6	800	950	1225	10	3896	4016	1768	4536	4656	2088	-	-	10590 *	6290 *	
1003-50.0,3	800	950	1225	8	3896	4016	1768	4536	4656	2088	-	-	9480 *	7310 *	
1003-50.0,6	800	950	1225	10	3896	4016	1768	4536	4656	2088	-	-	10880 *	8710 *	
1023-2-50.0,3	800	950	1225	8	3896	4016	1768	4536	4656	2088	-	-	12060 *	7760 *	
1023-2-50.0,6	800	950	1225	10	3896	4016	1768	4536	4656	2088	-	-	13460 *	9160 *	
1033-50.0,3	800	950	1225	8	3896	4016	1768	4536	4656	2088	6	11,5	8950 *	7780 *	
1033-50.0,6	800	950	1225	10	3896	4016	1768	4536	4656	2088	6	11,5	10350 *	9180 *	
1010-50.0,3	800	950	1225	8	3896	4016	1768	4536	4656	2088	-	-	11830 *	7530 *	
1010-50.0,6	800	950	1225	10	3896	4016	1768	4536	4656	2088	-	-	13230 *	8930 *	

Note: \* Clarified during designin



# All-Welded Vessels with Elliptic Bottom Head and Cover, with Smooth Welded Jacket

Make 1103, 1123

Make 1110

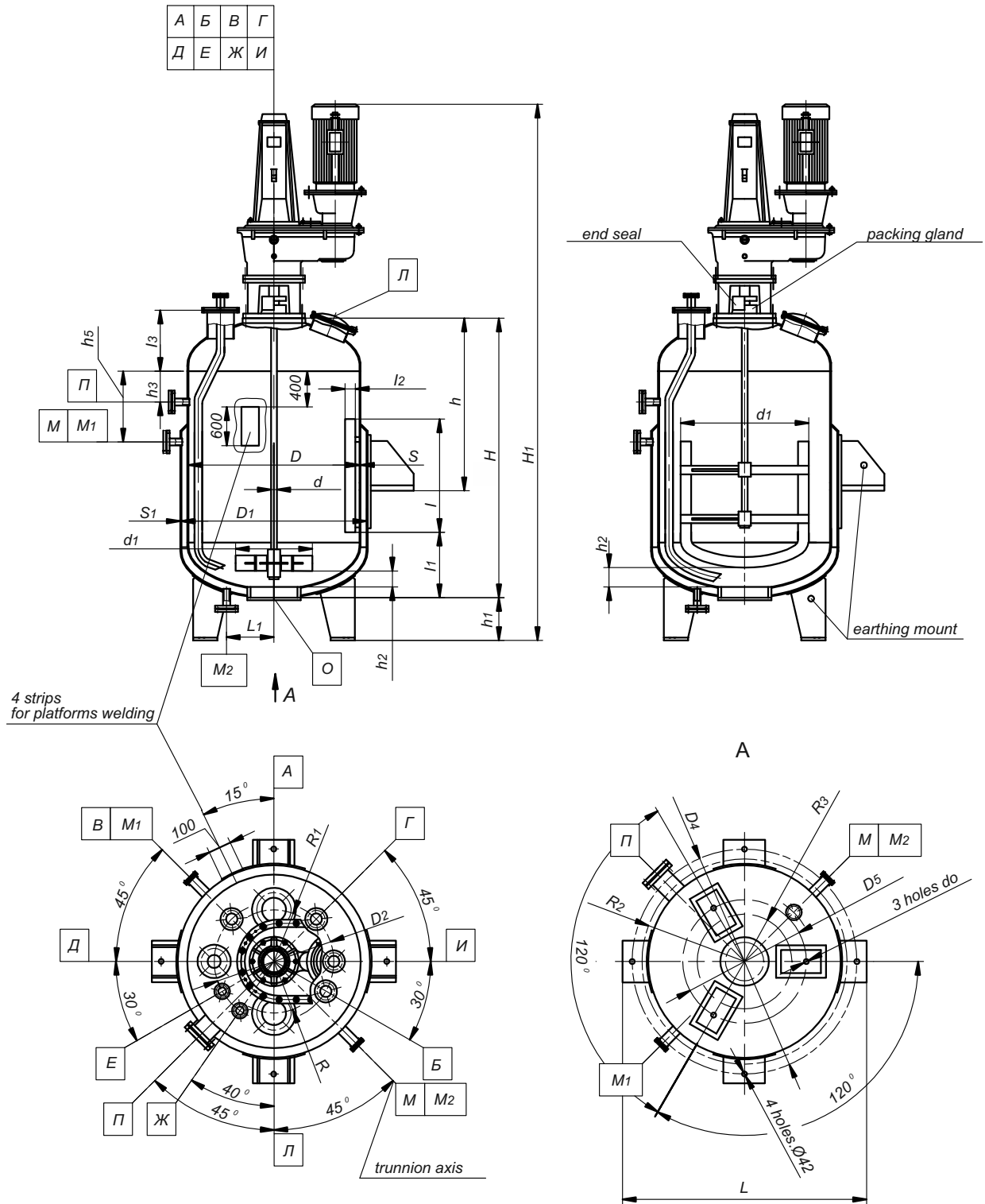

Fig.2.4



Main dimensions and weights of vessels

Table 2.13

Vessel make	mm																	
	D	D <sub>1</sub>	D <sub>2</sub>	D <sub>5</sub>	d	d <sub>1</sub>	H	H <sub>1</sub>	h	h <sub>1</sub>	h <sub>2</sub>	h <sub>3</sub>	h <sub>5</sub>	L <sub>1</sub>	l	l <sub>1</sub>	l <sub>2</sub>	l <sub>3</sub>
1103-10.0,6	2200	2400	1450	2210	95	710	3055	4835*	2010	335	630	120	460	375	-	-	-	685
1123-10.0,6	2200	2400	1450	2210	95	710	3055	5249*	2010	335	630	120	460	375	1600	550	220	685
1110-10.0,6	2200	2400	1450	2210	95	800	3055	5249*	2010	335	200	120	460	375	-	-	-	685
1103-16.0,6	2400	2600	1600	2410	95	710	3955	5885*	2070	485	730	120	475	375	-	-	-	720
1123-16.0,6	2400	2600	1600	2410	95	710	3955	6299*	2070	485	730	120	475	375	2400	600	240	720
1110-16.0,6	2400	2600	1600	2410	95	2000	3955	6299*	2070	485	200	120	475	375	-	-	-	720
1103-25.0,6	2800	3000	1800	2810	110	1250	4570	7174*	2415	745	730	150	530	450	-	-	-	810
1123-25.0,6	2800	3000	1800	2810	110	1250	4570	7174*	2415	745	730	150	530	450	2600	700	280	810
1110-25.0,6	2800	3000	1800	2810	110	2360	4570	7174*	2415	745	220	150	530	450	-	-	-	810
1103-3.2.0,6	3000	3200	2000	2960	110	1250	5070	7684*	2485	755	980	150	530	450	-	-	-	830
1123.23.2.0,6	3000	3200	2000	2960	110	1250	5070	7684*	2485	755	980	150	530	450	3000	750	300	830
1110-32.0,6	3000	3200	2000	2960	110	2500	5070	7684*	2485	755	250	150	530	450	-	-	-	830
1103-50.0,6	3000	3200	2000	2960	130	1250	7670	10284*	2485	755	1280	150	530	450	-	-	-	830
1123.250.0,6	3000	3200	2000	2960	130	1250	7670	10284*	2485	755	1280	150	530	450	3000	750	300	830
1110-50.0,6	3000	3200	2000	2960	130	2500	7670	10284*	2485	755	250	150	530	450	-	-	-	830



Table 2.13 (cont.)

Vessel make	R	R <sub>1</sub>	R <sub>3</sub>	S	S <sub>1</sub>	Lug supports								Heat exchanging surface, m <sup>2</sup>	Weight (max.), kg	
						normal				extended					Total	including nickel-containing steel
						D <sub>4</sub>	L	R <sub>2</sub>	D <sub>4</sub>	L	R <sub>2</sub>					
mm																
1103-10.0,6	600	700	985	16	12	2988	3068	1374	3408	3488	1584	16,4	7005*	4035*		
1123-10.0,6	600	700	985	16	12	2988	3068	1374	3408	3488	1584	16,4	7550*	4190*		
1110-10.0,6	600	700	985	16	12	2988	3068	1374	3408	3488	1584	16,4	7520*	4160*		
1103-16.0,6	650	750	1065	20	12	3308	3428	1514	3828	3948	1774	24,4	10490*	6330*		
1123-16.0,6	650	750	1065	20	12	3308	3428	1514	3828	3948	1774	24,4	11120*	6570*		
1110-16.0,6	650	750	1065	20	12	3308	3428	1514	3828	3948	1774	24,4	11050*	1460*		
1103-25.0,6	740	850	1225	22	14	3896	4016	1768	4536	4656	2088	32,7	16040*	10000*		
1123.2-25.0,6	740	850	1225	22	14	3896	4016	1768	4536	4656	2088	32,7	18550*	10380*		
1110-25.0,6	740	850	1225	22	14	3896	4016	1768	4536	4656	2088	32,7	18310*	10140*		
1103-3.2.0,6	800	950	1300	24	14	4096	4216	1868	4736	4856	2188	39,3	19500*	12680*		
1123.2-3.2.0,6	800	950	1300	24	14	4096	4216	1868	4736	4856	2188	39,3	22080*	13130*		
1110-32.0,6	800	950	1300	24	14	4096	4216	1868	4736	4856	2188	39,3	21860*	12910*		
1103-50.0,6	800	950	1300	28	14	4096	4216	1868	4736	4856	2188	63,8	31150*	21380*		
1123.2-50.0,6	800	950	1300	28	14	4096	4216	1868	4736	4856	2188	63,8	33730*	21832*		
1110-50.0,6	800	950	1300	28	14	4096	4216	1868	4736	4856	2188	63,8	33500*	21600*		

Note: \* Clarified during designing.





Table 2.14

Vessel make	D	D <sub>2</sub>	D <sub>4</sub>	D <sub>3</sub>	d	d <sub>1</sub>	d <sub>2</sub>	H	H <sub>1</sub>	h <sub>1</sub>	h <sub>2</sub>	h <sub>3</sub>	h <sub>5</sub>	h <sub>6</sub>
	mm													
1203-10.0,6	2200	1450	2500	2380	95	710	28	3055	5000*	500	630	120	315	1430
1223-10.0,6	2200	1450	2500	2380	95	710	28	3055	5580*	500	630	120	315	1430
1210-10.0,6	2200	1450	2500	2380	95	1800	28	3055	5580*	500	200	120	315	1430
1203-16.0,6	2400	1600	2720	2580	95	710	28	3955	6145*	500	730	120	400	2185
1223-16.0,6	2400	1600	2720	2580	95	710	28	3955	6480*	500	730	120	400	2185
1210-16.0,6	2400	1600	2720	2580	95	2000	28	3955	6480*	500	200	120	400	2185
1203-25.0,6	2800	1800	3120	3000	110	1250	35	4570	7395*	800	730	150	400	2415
1223.2-25.0,6	2800	1800	3120	3000	110	1250	35	4570	7395*	800	730	150	400	2415
1210-25.0,6	2800	1800	3120	3000	110	2360	35	4570	7395*	800	220	150	400	2415
1203-32.0,6	3000	2000	3360	3220	110	1250	35	5070	7895*	800	980	150	400	2875
1223.2-32.0,6	3000	2000	3360	3220	110	1250	35	5070	7895*	800	980	150	400	2875
1210-32.0,6	3000	2000	3360	3220	110	2500	35	5070	7895*	800	250	150	400	2875
1203-50.0,6	3000	2000	3360	3220	130	1250	35	7670	10495*	800	1280	150	620	5160
1223.2-50.0,6	3000	2000	3360	3220	130	1250	35	7670	10495*	800	1280	150	620	5160
1210-50.0,6	3000	2000	3360	3220	130	2500	35	7670	10495*	800	250	150	620	5160

Table 5.14 (cont.)

Vessel make	I	h <sub>1</sub>	I <sub>2</sub>	I <sub>3</sub>	R	R <sub>1</sub>	S	Heat exchanging surface, m <sup>2</sup>	Vessel weight (maximum), kg	
									Total	including nickel-containing steel
1203-10.0,6	-	-	-	685	600	700	12	14	4495*	2995*
1223-10.0,6	1600	550	220	685	600	700	12	14	5040*	3150*
1210-10.0,6	-	-	-	685	600	700	12	14	5010*	3120*
1203-16.0,6	-	-	-	720	650	750	12	23	5280*	3600*
1223-16.0,6	2400	600	240	720	650	750	12	23	5910*	3840*
1210-16.0,6	-	-	-	720	650	750	12	23	5840*	3770*
1203-25.0,6	-	-	-	810	740	850	12	30	7570*	5000*
1223.2-25.0,6	2600	700	280	810	740	850	12	30	10080*	5380*
1210-25.0,6	-	-	-	810	740	850	12	30	9840*	5140*
1203-32.0,6	-	-	-	830	800	950	12	36	8850*	6060*
1223.2-32.0,6	3000	750	300	830	800	950	12	36	11430*	6510*
1210-32.0,6	-	-	-	830	800	950	12	36	11210*	6290*
1203-50.0,6	-	-	-	830	800	950	12	38	10830*	8030*
1223.2-50.0,6	3000	750	300	830	800	950	12	38	13410*	8480*
1210-50.0,6	-	-	-	830	800	950	12	38	13180*	8250*

Note: \* Clarified during designing.



Make 8003, 8023, 8033

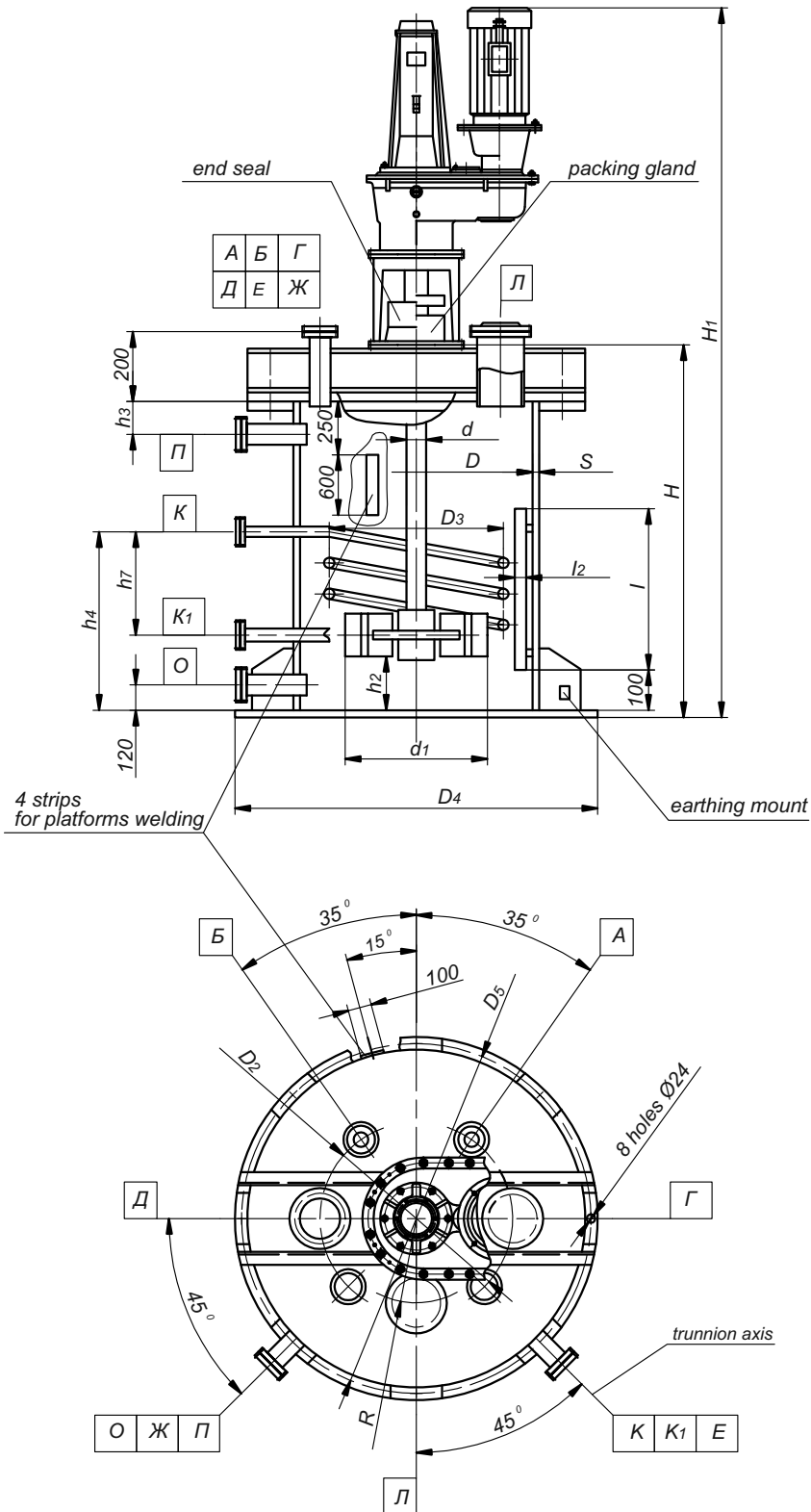

Fig.2.6





Main dimensions and weights of vessels

Table 2.15

Vessel make	D	D <sub>2</sub>	D <sub>3</sub>	D <sub>4</sub>	D <sub>5</sub>	d	d <sub>f</sub>	H	H <sub>1</sub>	h <sub>2</sub>	h <sub>3</sub>	H <sub>4</sub>	H <sub>7</sub>
	mm												
8003-1.0	1000	800	-	1130	1080	50	360	1430	2875*	190	250	-	-
8023-1.0	1000	800	-	1130	1080	50	360	1430	2875*	190	250	-	-
8033-1.0	1000	800	740	1130	1080	50	360	1430	2875*	190	250	600	450
8003-2.0	1400	1100	-	1530	1480	50	400	1455	2900*	250	250	-	-
8023-2.0	1400	1100	-	1530	1480	50	400	1455	2900*	250	250	-	-
8033-2.0	1400	1100	1060	1530	1480	50	400	1455	2900*	250	250	690	540
8003-3.2.0	1600	1200	-	1750	1700	65	450	1825	3270*	280	320	-	-
8023-3.2.0	1600	1200	-	1750	1700	65	450	1825	3270*	280	320	-	-
8033-3.2.0	1600	1200	1220	1750	1700	65	450	1825	3270*	280	320	780	630
8003-5.0	1800	1400	-	1950	1900	65	630	2225	3670*	395	400	-	-
8023-5.0	1800	1400	-	1950	1900	65	630	2225	3915*	395	400	-	-
8033-5.0	1800	1400	1380	1950	1900	65	630	2225	3670*	395	400	780	630
8003-6.3.0	1800	1400	-	1950	1900	65	630	2725	4170*	295	500	-	-
8023-6.3.0	1800	1400	-	1950	1900	65	630	2725	4415*	295	500	-	-
8033-6.3.0	1800	1400	1380	1950	1900	65	630	2725	4170*	295	500	780	630

Table 5.15 (cont.)

Vessel make	I	I <sub>2</sub>	R	S	Coil		Weight (max.), kg	
					number of laps	area, m <sup>2</sup>	Total	including nickel-containing steel
8003-1.0	-	-	370	-	-	-	805*	565*
8023-1.0	900	100	370	-	-	-	870*	590*
8033-1.0	-	-	370	5	2.3	910*	910*	630*
8003-2.0	-	-	500	-	-	-	1240*	930*
8023-2.0	800	140	500	-	-	-	1270*	960*
8033-2.0	-	-	500	6	3.3	1340*	1340*	1030*
8003-3.2.0	-	-	540	-	-	-	1770*	1275*
8023-3.2.0	1000	160	540	6	-	1810*	1810*	1315*
8033-3.2.0	-	-	540	7	4.9	1905*	1905*	1410*
8003-5.0	-	-	620	-	-	-	2170*	1650*
8023-5.0	1250	180	620	-	-	-	2580*	1710*
8033-5.0	-	-	620	7	5.5	2320*	2320*	1800*
8003-6.3.0	-	-	620	-	-	-	2790*	1830*
8023-6.3.0	1800	180	620	-	-	-	2875*	1915*
8033-6.3.0	-	-	620	7	5.5	2940*	2940*	1980*

Note: \* Clarified during designing.

Make 9003, 9023, 9033

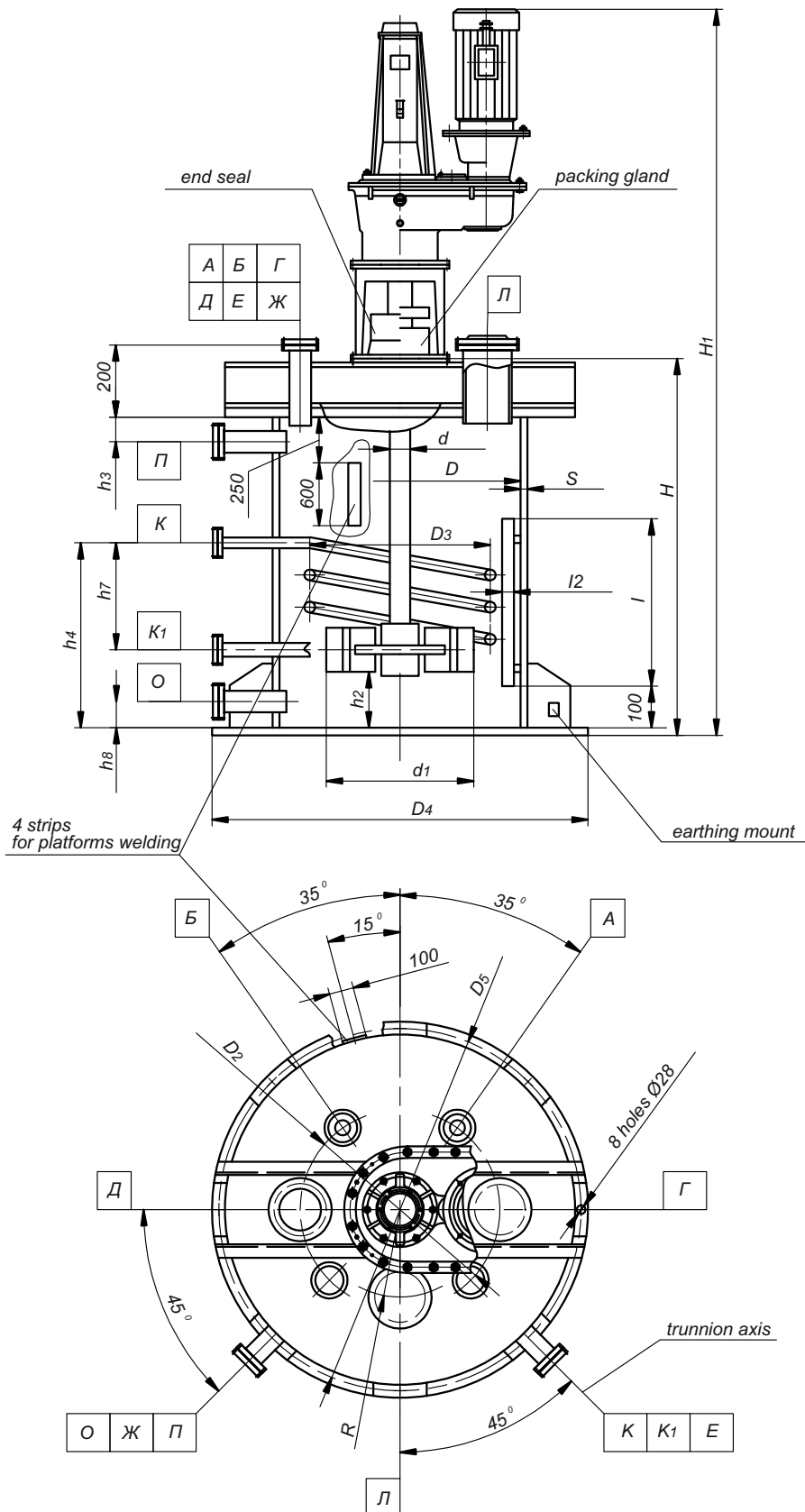

Fig.2.7



Table 2.16

## Main sizes and weights of apparatuses

Vessel make	D	D <sub>2</sub>	D <sub>3</sub>	D <sub>4</sub>	D <sub>5</sub>	d	d <sub>1</sub>	H	H <sub>1</sub>	h <sub>2</sub>	h <sub>3</sub>	h <sub>4</sub>	h <sub>7</sub>	h <sub>8</sub>
	mm													
9003-10.0	2200	1800	-	2360	2320	95	710	2880	4325*	400	520	-	-	-
9023-10.0	2200	1800	-	2360	2320	95	710	2880	4903*	400	520	-	-	-
9033-10.0	2200	1800	1610	2360	2320	95	710	2880	4325*	400	520	1280	1080	1080
9003-16.0	2400	1900	-	2560	2520	95	710	3880	5505*	450	720	-	-	-
9023-16.0	2400	1900	-	2560	2520	95	710	3880	5903*	450	720	-	-	-
9033-16.0	2400	1900	1830	2560	2520	95	710	3880	5505*	450	720	1145	945	945
9003-25.0	2800	2100	-	2960	2920	110	1250	4285	6308*	450	800	-	-	-
9023.2-25.0	2800	2100	-	2960	2920	110	1250	4285	6308*	450	800	-	-	-
9033-25.0	2800	2100	2150	2960	2920	110	1250	4285	6308*	450	800	1010	8100	8100
9003-32.0	3000	2200	-	3160	3120	110	1250	4785	6808*	500	900	-	-	-
9023.2-32.0	3000	2200	-	3160	3120	110	1250	4785	6808*	500	900	-	-	-
9033-32.0	3000	2200	2310	3160	3120	110	1250	4785	6808*	500	900	1010	810	810

Note: \* Clarified during designing.



Table 2.16 (cont.)

Vessel make	l	mm			S	Coil		Weight (max.), kg	
		l <sub>2</sub>	R	R		number of laps	area, m <sup>2</sup>	Total	including nickel-containing steel
9003-10.0	-	-	800	800	8	-	-	3715*	2455*
9023-10.0	2100	220	800	800	8	-	-	4260*	2610*
9033-10.0	-	-	800	800	8	8	11.1	4170*	2910*
9003-16.0	-	-	850	850	8	-	-	4660*	3380*
9023-16.0	2900	240	850	850	8	-	-	5290*	3620*
9033-16.0	-	-	850	850	8	7	10.7	5090*	3810*
9003-25.0	-	-	950	950	10	-	-	7320*	5430*
9023.2-25.0	3200	280	950	950	10	-	-	9830*	5810*
9033-25.0	-	-	950	950	10	6	10.7	7760*	5870*
9003-32.0	-	-	1000	1000	10	-	-	8320*	6380*
9023.2-32.0	3600	300	1000	1000	10	-	-	10900*	6830*
9033-32.0	-	-	1000	1000	10	6	11.5	8790*	6850*

Note: \* Clarified during designing.



Designation of the apparatus \_\_\_\_\_ Quantity \_\_\_\_\_

1. Operating pressure in the shell:

gauge, kgf/cm<sup>2</sup> \_\_\_\_\_ residual, MPa \_\_\_\_\_

Operating gauge pressure in the jacket, kgf/cm<sup>2</sup> \_\_\_\_\_

2. Operating temperature of the medium, °C:

in the shell \_\_\_\_\_ in the jacket \_\_\_\_\_

Shell wall design temperature, °C \_\_\_\_\_

Corrosion in the shell \_\_\_\_\_

3. Operating medium components \_\_\_\_\_

---

---

---

Fire hazard (yes, no) \_\_\_\_\_ Explosion hazard (yes, no) \_\_\_\_\_

Presence of highly poisonous substances (yes, no) \_\_\_\_\_

4. The need to perform intercrystalline corrosion tests per the AM GOST 6032 method (yes, no)

---

5. The need to install the calm down pipe (yes, no) \_\_\_\_\_

6. Vessel supports (leg supports, lug supports, extended lug supports, cylindrical support, ring support)

---

7. The need to weld-on heat insulation fasteners (yes, no) \_\_\_\_\_

The need to weld-on strips for platforms and ladders (yes, no) \_\_\_\_\_

8. Motor feed voltage, V \_\_\_\_\_

Current frequency, Hz \_\_\_\_\_

9. Vessel installation location (indoors, outdoors) \_\_\_\_\_

Climatic make per GOST 15150 (U2 T2) \_\_\_\_\_

10. Technological process carried out in the vessel \_\_\_\_\_



## 11. Main valves, instrumentation and safety devices

Name	Q-ty	DN	PN, kgf/cm <sup>2</sup>	Material	Installation location

Note: The table is filled out for vessels with operating gauge pressure above 0,7 kgf/cm<sup>2</sup> for the preparation of the vessel's passport. Valves and instruments are not included in the scope of supply.

12. Valves and instrumentation are included in the scope of supply (yes, no): \_\_\_\_\_

13. Name, postal code, post and telegraph address, telephone number of the enterprise that has filled out the data sheet.

---



---



---



---



---



---



---



---



---



---

Position, name \_\_\_\_\_ Signature \_\_\_\_\_ Date \_\_\_\_\_  
of the authorized person (certified with a seal)



## Data Sheet for Order of Mechanical Seal for Complete Vessel with Agitator

---

Designation of the apparatus \_\_\_\_\_

1. Stirred liquid data:

Name \_\_\_\_\_

Composition (components); concentration \_\_\_\_\_

Operating/max. temperature \_\_\_\_\_

PH \_\_\_\_\_

Presence of solids \_\_\_\_\_ Yes No

Liquid crystallization \_\_\_\_\_ Yes No

Sealing liquid \_\_\_\_\_

2. Seal data

Preferred seal type \_\_\_\_\_ Single Double Tandem

Preferred friction couples material \_\_\_\_\_

Preferred sealing rings material \_\_\_\_\_

Presence of cooling/washing liquid \_\_\_\_\_ Yes No

3. Name, postal code, post and telegraph address, telephone number of the enterprise that has filled out the data sheet

\_\_\_\_\_  
\_\_\_\_\_

Position, name \_\_\_\_\_ Signature \_\_\_\_\_ Date \_\_\_\_\_  
of the authorized person (certified with a seal)



# Oil, Oil Product and Water Storage Tanks

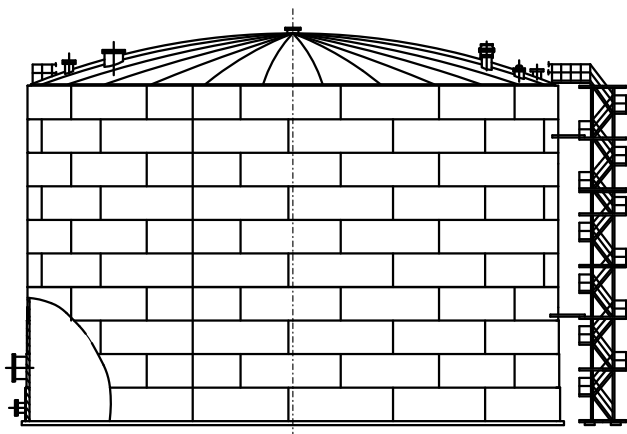



Vertical steel tank (RVS) is a welded cylindrical vessel with a certain internal diameter and wall height that are characteristic to this typical size of the tank. Tanks are made per Typical Projects with changes in accordance with new rules of the RVS arrangement.

A tank is used for the storage of oil and oil products with density of maximum  $1 \text{ t/m}^3$ , and also water. A tank is installed flat head to the concrete bed at the operation location.

The tank roof is conical in shape and made out of plates.

Tanks include stair towers for maintenance of tank equipment located on the roof. It also serves as a supporting structure for tank wall transportation to the installation location.

The main material of the tank: low-alloy steel, carbon steel.

#### Main maximum design provisions used for tank designing

1. Product density	up to $1 \text{ t/m}^3$
2. Snow load	up to $2 \text{ KPa}$ ( $20 \text{ kgf/cm}^2$ )
3. Wind head	up to $1 \text{ KPa}$ ( $10 \text{ kgf/cm}^2$ )
4. Minimum ambient air temperature	up to minus $60^\circ\text{C}$

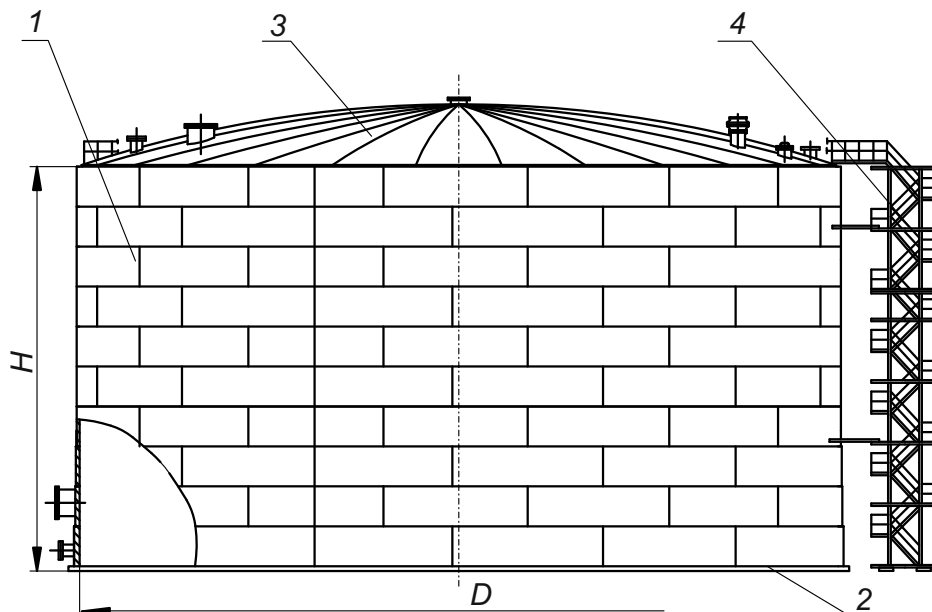

- 1 – Wall
- 2 – Head
- 3 – Roof
- 4 – Stairs tower

Height H and diameter D depend on the tank volume.

Arrangement of manholes and nozzles according to the Typical Project, on the basis of which this tank is manufactured.



## Main dimensions of typical tanks

Table 3.1

Volume, m <sup>3</sup>	Height H, mm	Diameter D, mm
200	5980	6630
300	7450	7580
400	7450	8590
500	5960	10430
700	8940	10430
1000	11920	10430
2000	11920	15180
3000	11920	18980
5000	14900	20920
10000	17900	28500
20000	17900	39900

Pontoons are used to reduce losses from products evaporation. Per the customer's desire, polymer and aluminum pontoons can be used.

Breathing devices are installed on the stationary roof according to the Typical project. They include, depending on the tank type, breather valves, safety valves, flame arresters, vent nozzles.

Tanks are packaged with high level alarms.

Per the customer's desire, a tank can be equipped with the following instrumentation:

1. Low level alarm;
2. Reflex level gauge;
3. Fluid and air temperature gauge for mediums inside the tank.

A tank is packaged with fire and lightning safety equipment according to the Typical Project.

## Tanks can be equipped as follows:

Table 3.2

No.	Name
1.	Skylight
2.	Installation manhole
3.	Manhole hatch of the I belt, oval
4.	Manhole hatch of the I belt
5.	Manifold (purchased)
6.	Roof lightning rod
7.	Pre-heating system
8.	Cap valve with a control mechanism (purchased)
9.	GPS medium-foam generator (purchased)
10.	KDS breather combination valve (purchased)
11.	Flame arrester (purchased)
12.	Sampler (purchased)
13.	Vent nozzle
14.	Pontoon (purchased)



# Horizontal Underground Drain Vessels

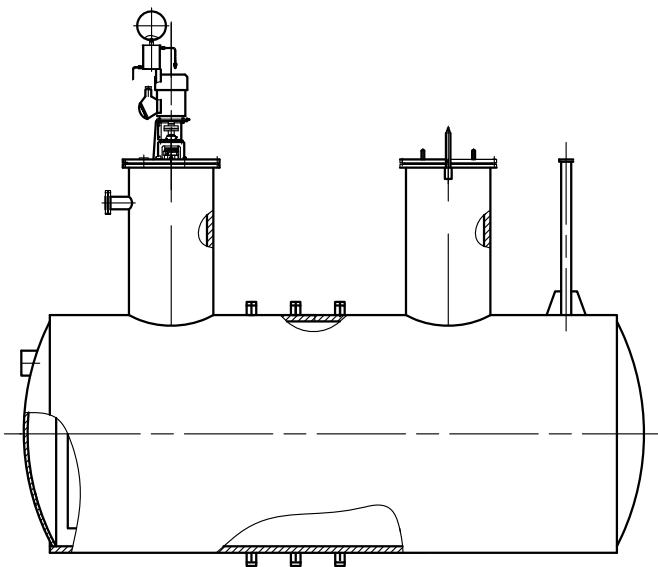

**The Company manufactures two types of underground vessels:**

- EP** - underground vessels without a pre-heater;  
**EPP** - underground vessels with a pre-heater.

Technical requirements to materials, fabrication, acceptance, test methods and preservation of apparatuses per SOU MPP 71.120-217:2009, GOST R 52630 and CU TR 032/2013.

Material makes:

- make 1 - for regions with the average temperature of the coldest five-days period not lower than minus 20°C;
- make 2 - for regions with the average temperature of the coldest five-days period not lower than minus 40°C;
- make 3 - for regions with the average temperature of the coldest five-days period not lower than minus 60°C.

Vessels of all types shall be furnished with heated concrete pits for regions with the average temperature of the coldest five-days period lower than minus 40°C.

Vessels are packaged with an electric pump unit HPE 80-50-200-D-55.

**Vessel designation example when ordering:**

- vessel without pre-heater (EP), nominal volume 25 m<sup>3</sup>, internal diameter 2400 mm, design make 1, material make 1, without a concrete pit:

**EP 25-2400-1.**

Same, but with heat treatment:

**EP 25-2400-1-T.**

- vessel without pre-heater (EP), nominal volume 16 m<sup>3</sup>, internal diameter 2000 mm, design make 1, material make 2, equipped with a concrete pit (K):

**EP 16-2000-2-K.**

Same, but with heat treatment:

**EP 16-2000-2-T-K.**

- vessel with a pre-heater (EPP), nominal volume 40 m<sup>3</sup>, internal diameter 2400 mm, design make 2, material make 3, equipped with a concrete pit (K):

**EPP 40-2400-3-K.**

Same, but with heat treatment (T):

**EPP 40-2400-3-T-K.**

Vessels can be ordered without an electric pump unit.

**Designation example for underground drain vessels supplied without an electric pump unit:**

- vessel without pre-heater (EP), nominal volume 40 m<sup>3</sup>, internal diameter 2400 mm, neck height 1600 mm, corresponding to the design make 1, with material make 2, equipped with a concrete pit:

**EP 40-2400-1600-2-K.**

Same, but with heat treatment.

**EP 40-2400-1600-2-T-K.**

Same, but with a pre-heater:

**EPP 40-2400-1600-2-T-K.**

Same, but without a concrete pit:

**EP 40-2400-1600-2-T.**

**Material make**

Table 4.1

Average temperature of the coldest five-days period, °C		minus 20	minus 40	minus 60
Material make index		1	2	3
Materials of:	shell, heads, flange stiffening rings, blinds, manholes	Ст3пс4 GOST 380 20K-5 GOST 5520 for S>25 mm	Steel 09Г2С-6 GOST 5520	Steel 09Г2С-8 GOST 5520
	nozzles of:			
	manholes			
	nozzles	Steel 20 GOST 1050		Steel 10Г2 GOST 4543
	strips, gussets	Ст3пс4 GOST 380		Steel 09Г2С GOST 5520
	pipes	Steel 20 GOST 1050		Steel 10Г2 GOST 4543
Fastening	external	Steel of grades: 35, 40 GOST 1050		
	internal	Steel 20X13 GOST 5632		

\* Vessels are manufactured per SOU MPP 71.120-217:2009, GOST R 52630 and CU TR 032/2013.



# 100 Horizontal Underground Drain Vessels

Table of nozzles and manholes

Table 4.2

Designation	Service	Q-ty	Nominal diameter DN	Nominal pressure PN MPa (kgf/cm <sup>2</sup> )	Outreach, mm
A	Manhole	1	800	0.25 (2.5)	–
Б	Manhole for pump	1	700	0.25 (2.5)	–
B	Product inlet	1	200	–	–
Г	Product outlet	1	65	–	–
Д	Emergency product outlet	1	150	–	–
E	Steam inlet	1	100	1.6 (16)	200
Ж	Air tap	1	100	1.6 (16)	200
З	For level gauge	1	65	4.0 (40)	–
И	For thermal transducer	1	50	–	–
*1K	Heat transfer fluid inlet	1	20	–	–
*1Л	Heat transfer fluid outlet	1	20	–	–
*2M	Heat transfer fluid inlet	1	20	–	–
*2H	Heat transfer fluid inlet	1	20	–	–

\*1 – for EPP-type vessels.

\*2 – for vessels with a concrete pit.

Main design dimensions, mm

Table 4.3

Nominal volume V <sub>n</sub> , m <sup>3</sup>	8	12.5	16	20	25	40	63	
Vessel make	1				2			
Д	2000			2400		3000		
L	2880	4280	5280	4826	5826	9026	9244	
H	4925				5235		5240	
S	8						10	
h	1300			900		1000	1000	
h1	600			800			1100	
L1	2400	3800	4800	4200	5200	8400		
L2	–	–	–	–	1834	5841	5892	
l1	–	–	–	–	1834	1947	1964	
n	–	–	–	–	1	3		
l2	1050	1620	2350	1750	2700	5840		
l3	700	730	1000					
l4	500	1020				1220		
l5	2050			2450			3050	
l6	570			680			800	
l7	610	1820	2550	1950	3200	6040		
l8	–	1900	2400	2100	1833	1650		
l9	–	910	1275	975	1600	2000		
l10	–	–	–	–	–	2040		



## Weight of vessels not subject to heat treatment

Table 4.4

Parameters		Nominal volume $V_H, m^3$							
		8	12.5	16	20	25	40	63	
Design make of vessel		1				2			
Electric pump unit HPE 80-50-200-D-55	Motor type	AIMS 160 MVU 2.5							
	Motor capacity, kW	15							
Metal structures of the concrete pit		370							
Electric pump unit HPE 80-50-200-D-55		570				575			
Weight, kg, maximum	EP type	Vessels	2125	2680	3080	3270	3870	5635	8230
		Vessels with electric pump unit HPE 80-50-200-D-55	2695	3250	3650	3840	4440	6210	8805
		Vessels with electric pump unit HPE 80-50-200-D-55 and metal structures	3065	3620	4020	4210	4810	6580	9175
EPP type	Vessels	2150	2720	3130	3310	3940	5735	8430	
	Vessels with electric pump unit HPE 80-50-200-D-55	2720	3290	3700	3880	4510	6310	9005	
	Vessels with electric pump unit HPE 80-50-200-D-55 and metal structures	3090	3660	4070	4250	4880	6680	9375	

## Weight of vessels subject to heat treatment

Table 4.5

Parameters		Nominal volume $V_H, m^3$							
		8	12.5	16	20	25	40	63	
Design make of vessel		1				2			
Electric pump unit HPE 80-50-200-D-55	Motor type	AIMS 160 MVU 2.5							
	Motor capacity, kW	15							
Metal structures of the concrete pit		370							
Electric pump unit HPE 80-50-200-D-55		570				575			
Weight, kg, maximum	EP type	Vessels	2125	2680	3080	3800	4490	6630	9480
		Vessels with electric pump unit HPE 80-50-200-D-55	2695	3250	3650	4370	5060	9205	10055
		Vessels with electric pump unit HPE 80-50-200-D-55 and metal structures	3065	3620	4020	4740	5430	9575	10425
EPP type	Vessels	2165	2720	3130	3840	4560	6730	9680	
	Vessels with electric pump unit HPE 80-50-200-D-55	2735	3290	3700	4410	5130	7305	10255	
	Vessels with electric pump unit HPE 80-50-200-D-55 and metal structures	3105	3660	4070	4780	5500	7675	10625	



EP-type vessels

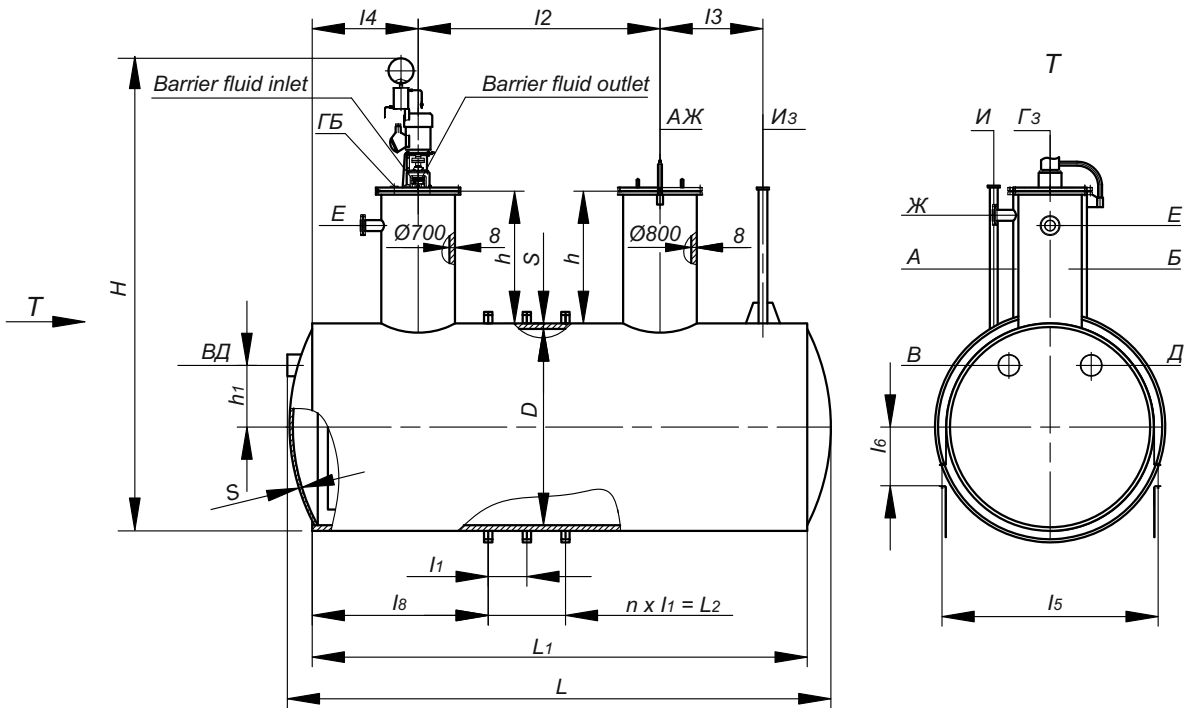

EPP-type vessels

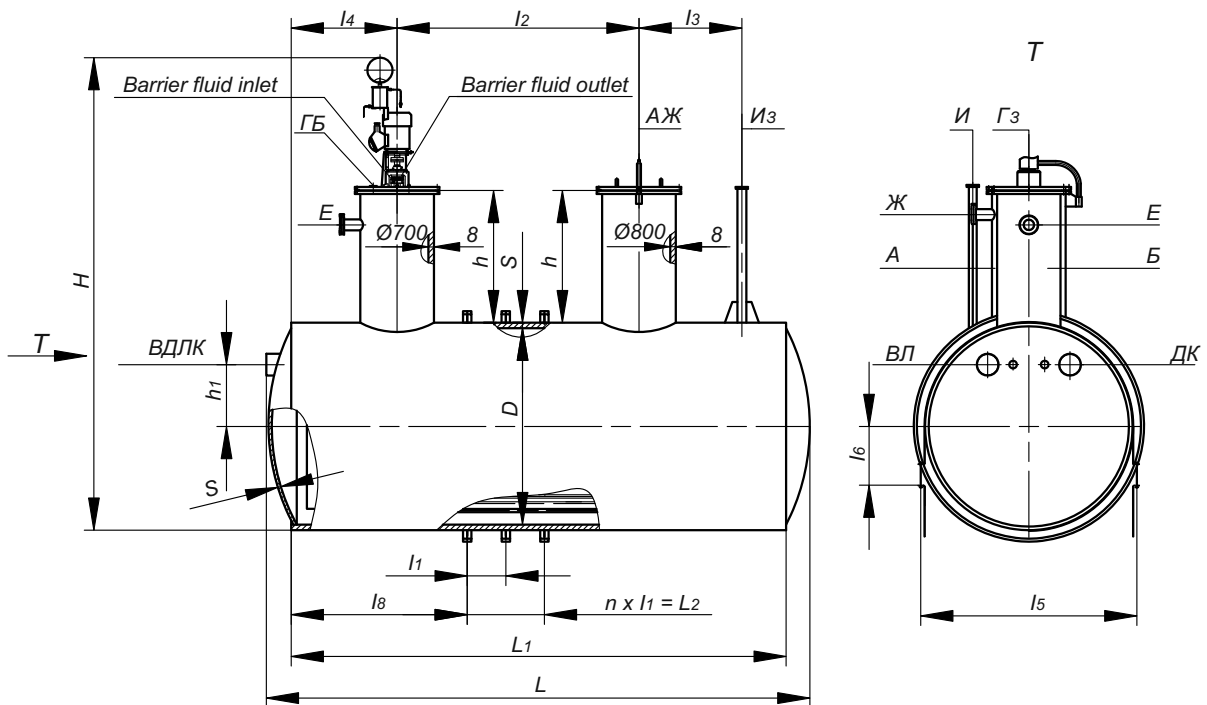

EP-type vessels subject to heat treatment

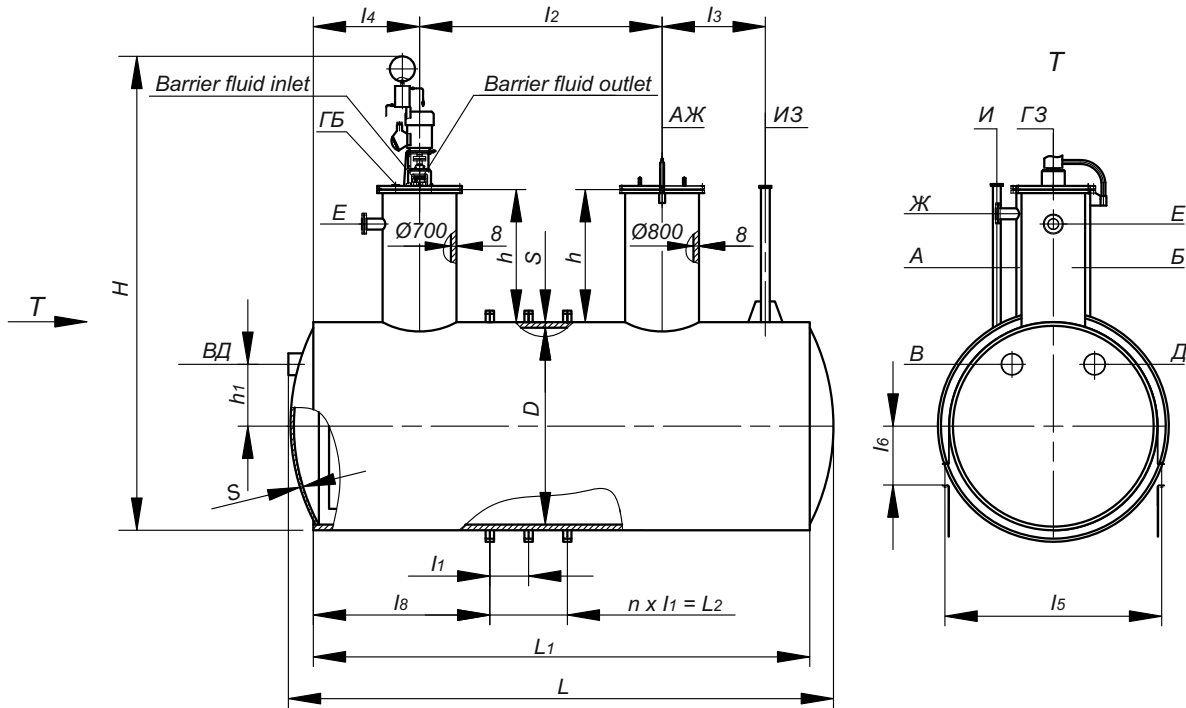

EPP-type vessels subject to heat treatment

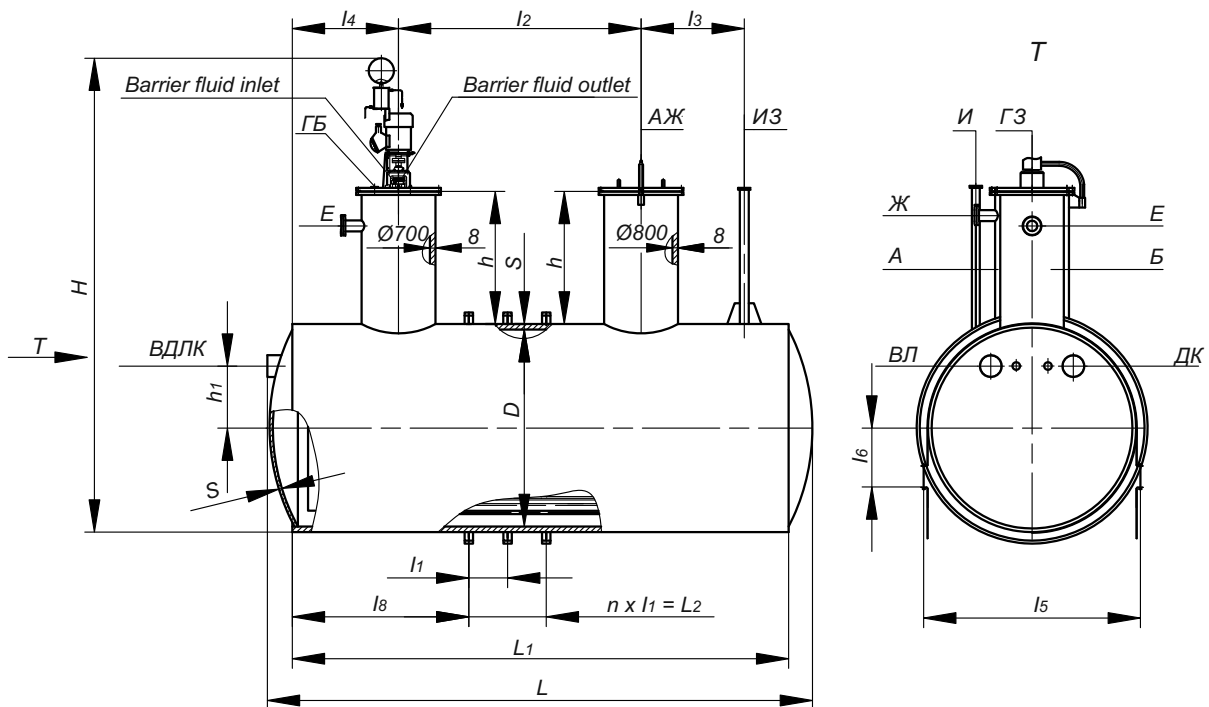



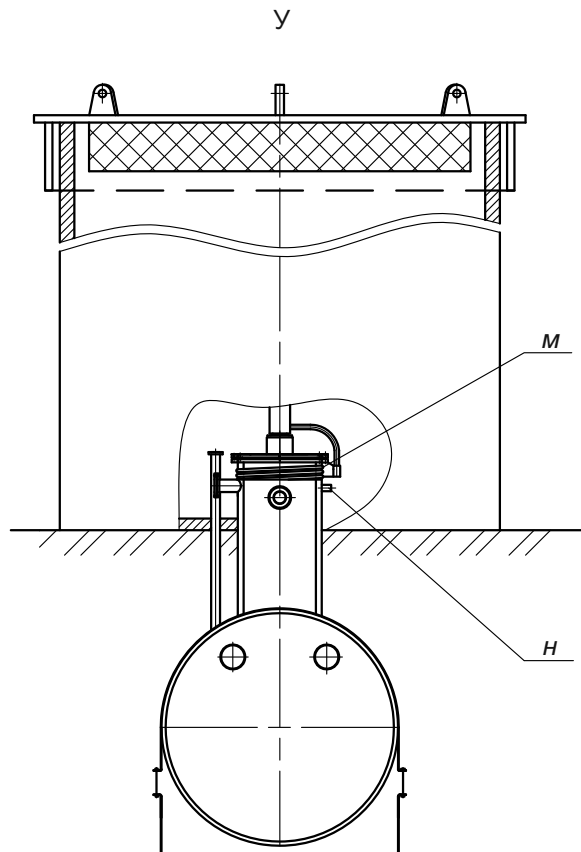
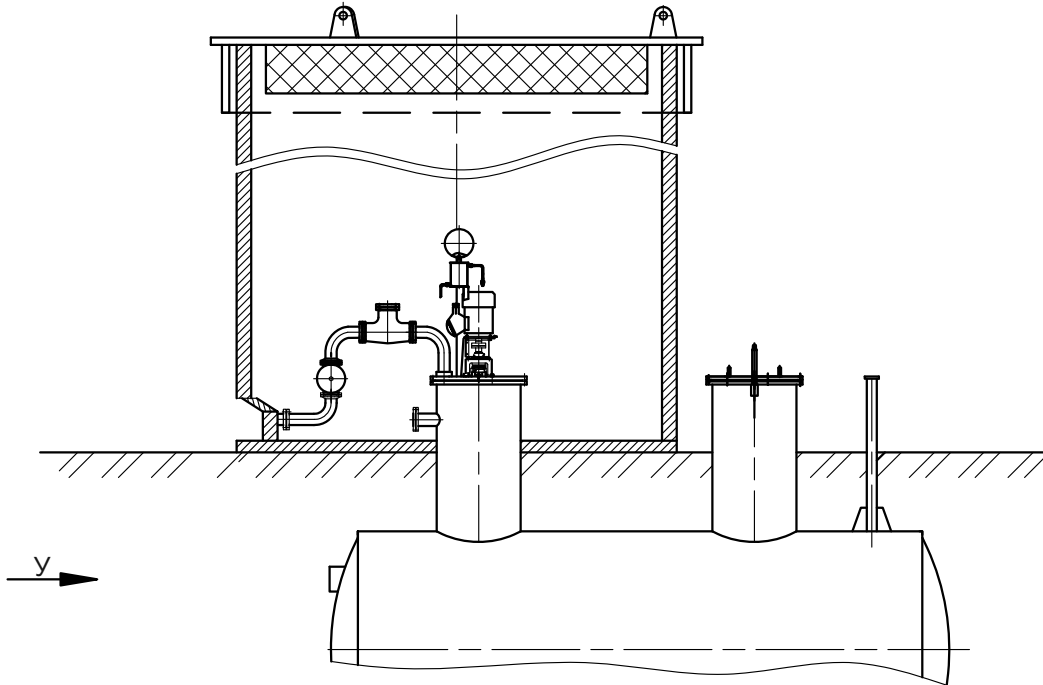

# Air Collectors-Receiver for Air Stationary Compressors

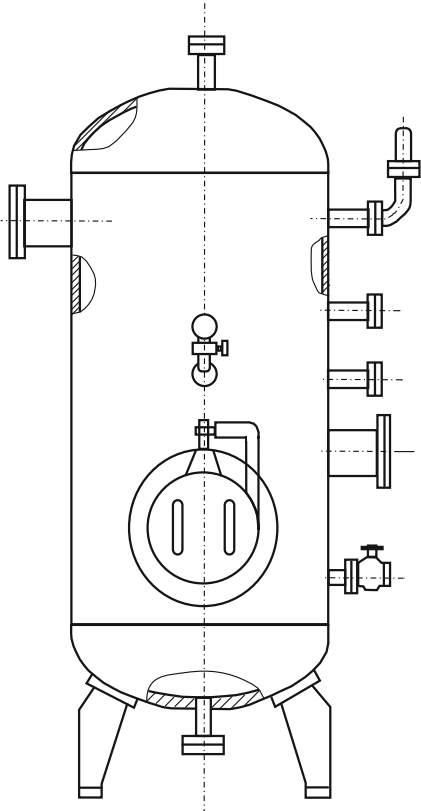

Air collectors with nominal volumes: 0.5; 1.0; 1.6; 2.0; 3.2; 4.0; 6.3; 8.0; 10; 16; 20; 25; 32; 40; 50 m<sup>3</sup> and operating pressures: 0.8; 1.0; 1.4 MPa (8, 10, 14 kgf/cm<sup>2</sup>) are used to reduce pressure drops in air pipelines and to create air reserve during operation of general-purpose air stationary compressors, as well as air compressors with discharge pressure up to 1.4 MPa (14 kgf/cm<sup>2</sup>).

Air collectors can be used as receivers and storage vessels for nitrogen, argon and other inert gases.

Air collectors are designed for operation in areas with the seismicity value of less than 7 per the twelve-positions scale.

Upon replacement of leg supports with cylindrical supports, it is allowed to operate air collectors less than 10 m high in areas with seismicity value up to 9 and at air collector height more than of 10 m – under the condition of verification with a seismic strength calculation.

Climatic makes of air collectors:

1. When shipping to areas with moderate and cold climate - UHL1 per GOST 15150.
2. When shipping to areas with tropical climate - T1 per GOST 15150.

Air collectors can be operated in the low-cycle loading mode – with periodic increase and decrease of pressure. Low-cycle loading case shall be specified by the consumer organization, when ordering an air collector.

Example of designation, when ordering and in other documents, of an air collector with the nominal volume of 4 m, designed for operating pressure of 0.8 MPa, material make 3, climatic make UHL1:

**Air Collector V-4-0.8-3-UHL1**

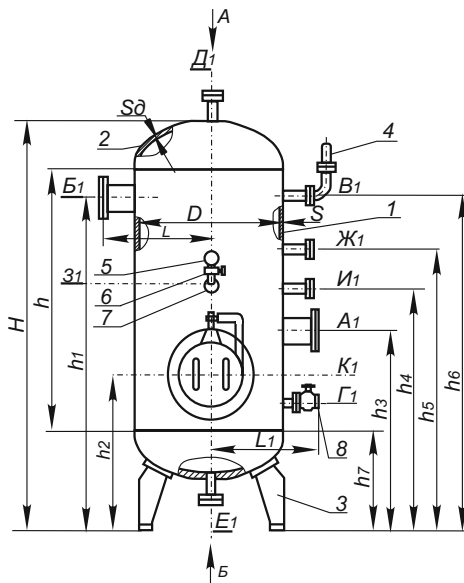

Fig. 5.1

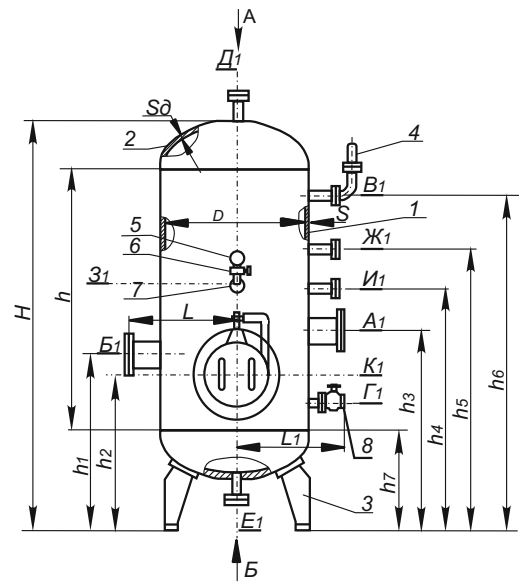
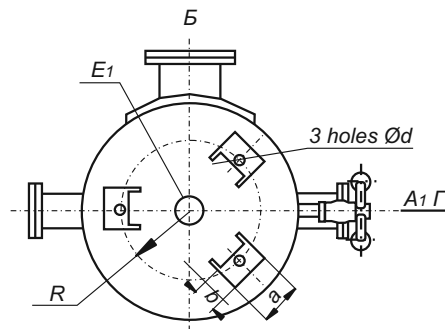
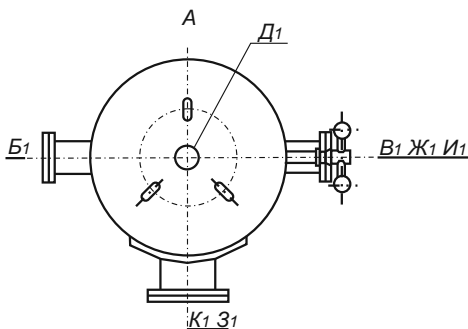

Fig. 5.2



- 1 – Shell
- 2 – Head
- 3 – Support
- 4 – Safety valve
- 5 – Pressure gauge
- 6 – Three-way valve
- 7 – Union elbow
- 8 – Stop couple valve

Air collector V-50 is shipped with cylindrical support. Views A and B show the two safety valves installation variant.



Main sizes and masses of apparatuses

Table 5.1

Size-type of the air collector	Nom. volume, m <sup>3</sup>	Fig. No.	Design pressure, MPa (kgf/cm <sup>2</sup> )	D	S*	Sd*	H	h	h <sub>1</sub>	h <sub>2</sub>	h <sub>3</sub>	h**	h <sub>5</sub>	h <sub>6</sub>	h <sub>7</sub>	L	L <sub>1</sub>	R	a	b	d	Weight, kg		
V-0.5	0.5	5.1	0.9(9.0)		6	6																	295	
			1.0(11.0)	600	6	6	2000	1500	1700	460	850	1500	1700	-	310	400	460	260	100	85	19		295	
			1.54(15.4)		6	6																		
V-1	1.0		0.9(9.0)		6	6																		415
			1.0(11.0)	800	6	6	2340	1700	1800	550	950	1600	1850	-	400	500	560	360	130	110	19		415	
			1.54(15.4)		8	8																		
V-1.6	1.6		0.9(9.0)		6	6																		695
			1.0(11.0)	1000	8	8	2300	1600	1800	900	1050	1600	1850	-	410	600	660	460	130	110	19		825	
			1.54(15.4)		10	10																		
V-2	2.0	0.9(9.0)		6	6																		800	
		1.0(11.0)	1000	8	8	2900	2200	2450	900	1050	2200	2450	-	410	610	660	460	160	130	24		950		
		1.54(15.4)		10	10																			1110
V-3.2	3.2	0.9(9.0)		8	8																		1195	
		1.0(11.0)	1200	8	8	3160	2300	2500	1000	1250	2200	2500	-	505	720	760	550	160	130	24		1195		
		1.54(15.4)		10	10																			1420
V-4	4.0	0.9(9.0)		8	8																		1385	
		1.0(11.0)	1200	8	8	3860	3000	3250	1000	1250	2400	2700	3100	505	720	720	550	160	130	24		1385		
		1.54(15.4)		10	10																			1655
V-6.3	6.3	0.9(9.0)		8	8																		1830	
		1.0(11.0)	1400	10	10	4565	3600	3800	1050	1300	2500	2850	3300	555	830	830	630	200	160	35		2190		
		1.54(15.4)		12	12																			2545



# 108 Air Collectors-Receiver for Air Stationary Compressors

Table 5.1 (cont.)

Size-type of the air collector	Nom. volume, m <sup>3</sup>	Fig. No.	Design pressure, MPa (kgf/cm <sup>2</sup> )	D	S*	S <sub>A</sub> *	H	h	h <sub>1</sub>	h <sub>2</sub>	h <sub>3</sub>	h**	h <sub>5</sub>	h <sub>6</sub>	h <sub>7</sub>	L	L <sub>1</sub>	R	a	b	d	Weight, kg	
V-8	8.0	5.1	0.9(9.0)		8	8																1995	
			1.0(11.0)	1600	10	10	4415	3300	3600	1150	1450	2650	3000	3450	650	940	960	705	200	160	35	2390	
			1.54(15.4)		12	12																	
V-10	10		0.9(9.0)		8	8																	2445
			1.0(11.0)	1600	10	10	5515	4400	4700	1150	1450	2800	3150	3600	650	940	960	705	230	200	35	2940	
			1.54(15.4)		12	12																	
V-16	16		0.9(9.0)		10	10																	3785
			1.0(11.0)	2000	12	12	5520	4200	4550	1250	1600	2800	3200	3750	745	1150	1160	905	290	250	42	4415	
			1.54(15.4)		14	14																	
V-20	20	0.9(9.0)		10	10																	4455	
		1.0(11.0)	2000	12	12	6870	5400	5900	1400	1750	2900	3300	3850	895	1150	1160	905	290	250	42	5215		
		1.54(15.4)		14	14																		6000
V-25	25	0.9(9.0)		10	10																	5285	
		1.0(11.0)	2200	12	12	7155	5600	6000	1400	1750	2900	3350	3900	910	1250	1260	1002	390	340	42	6175		
		1.54(15.4)		16	16																		7935
V-32	32	0.9(9.0)		12	12																	7395	
		1.0(11.0)	2400	12	12	7775	6000	-	1600	2000	3600	4050	4600	1100	1350	1360	1105	390	340	42	7395		
		1.54(15.4)		16	16																		9460
V-40	40	0.9(9.0)		12	12																	9095	
		1.0(11.0)	2400	12	12	9775	8000	-	1600	2000	3600	1050	4600	1100	1350	1360	1105	500	450	42	9695		
		1.54(15.4)		16	60																		12285



Table 5.1 (cont.)

Size-type of the air collector	Nom. volume, m <sup>3</sup>	Fig. No.	Design pressure, MPa (kgf/cm <sup>2</sup> )	D	S*	Sd*	H	h	h <sub>1</sub>	h <sub>2</sub>	h <sub>3</sub>	h**	h <sub>5</sub>	h <sub>6</sub>	h <sub>7</sub>	L	L <sub>1</sub>	R	a	b	d	Weight, kg		
V-50	50	5.2	0.9(9.0)		12	12																	11705	
			1.0(11.0)	2400	12	12	11775	10000	-	1600	2000	3600	4050	4600	1100	1350	1360	-	-	-	-	-	-	11705
			1.54(15.4)		16	16																		

Types and quantity of safety valves

Table 5.2

Nominal volume of the air collector, m <sup>3</sup>	Maximum allowable compressor output, m <sup>3</sup> /min	Number of safety valves, pcs.	Safety valve throughput, m <sup>3</sup> /min	Safety valve type	Двсл-1, mm	PN+1, kgf/cm <sup>2</sup>	d <sub>0</sub>	Flow factor, α
0.5 1.0	0.6 1.5	1	2.06	СППК4Р25-40*	25	40	17	0.6
1.6 2.0 3.2	3.0 5.0 10	1	10.33	СМПК4Р-30-16*	50	16	33	0.8
4.0	20	2	10.33x2-20.66					
6.3	30	2	15.2x2-30.4	СППК4Р80-16*	80	16	40	0.8
8	50	1	53.3	СПГ1К4Р 150-16М*	150	16	75	0.8
10	100	2	53.3x2-106.6					
16	150	3	53.3x3-159.9					
20	190	2		СППК4Р-200-16*	200	16	142	0.4
25 32	250 280	3						
40 50	380 380	4	95.6x4-382.4					

## Notes:

- Air collectors working with compressors that have smaller output than the one in the table, shall be furnished with safety valves with throughput corresponding with the compressor output.
- Safety valves of the СППК4Р-150-16 type (without letter "M") have throughput capacity of 26.65 m<sup>3</sup>/min at flow factor α=0.4.
- It is possible to replace safety valves of this type with their equivalents.



# 110 Air Collectors-Receivers for Air Stationary Compressors

Nozzles service and nominal diameters

Table 5.3

Designation	Name	Air collector volume, m <sup>3</sup>											
		0.5:1	1.6:2	3.2	4	6.3	8	10	15	20	25	32	40,50
A <sub>1</sub>	Air inlet	50	100	200		250		300		350			
Б <sub>1</sub>	Air outlet	50	100	200		250		300		350			
B <sub>1</sub>	For safety valve	25	50		80		150			200			
	Quantity	1	1	2	2		1	2	3	2	3	4	
Г <sub>1</sub>	Condensate drain	50											
Д <sub>1</sub>	Air tap	50											
Е <sub>1</sub>	Drain	50											
Ж <sub>1</sub>	To the output regulator	50											
З <sub>1</sub>	For pressure gauge	50											
И <sub>1</sub>	To pressure gauge to the machine room	50											
К <sub>1</sub>	Manhole	80	450										

Note:

- The quantity and the arrangement of nozzles can be changed per the Customer requirements;
- Per the agreement with the Customer, air collector can be packaged with all the necessary stop valves, safety valves and instrumentation;
- When installing several safety valves, their respective nozzles shall be located on the same height and at a distance big enough to prevent mutual interference of the holes;
- When installing several safety valves on one nozzle, the area of the nozzle pipe cross-section shall be not less than 1.25 times the total cross-section area of valves installed on it;
- Bosses for instrumentation shall be welded to the blind flanges of nozzles;
- On air collectors with the volume of 0.5:1.0; 1.6:2.0 and 3.2 m<sup>2</sup>, safety valve is installed onto the Д1 nozzle. A DN 25 safety valve is installed via a transition piece.



# 111 Air Collectors-Receivers for Air Stationary Compressors

## Material make

Table 5.4

Allowable minimum pressure-containing wall temperature, °C	Operating pressure, MPa	Material make code	Sheet steel	Nozzles	Fasteners
Minus 20	0.8 1.0 1 1.4	1	Ст3сп, Cr3пс, Ст3Гпс of categories 4 and 5 GOST 380, GOST 14637	Steel 10 and 20 GOST 1050, Group A.Б GOST 550, Group B GOST 8731	Steel 35 GOST 1050, Steel 35X GOST4543, OST 26-2043
Minus 40	0.8 1.0 1.4	2	16ГC, 09Г2C, 10Г2C1 of categories 6 and 12 GOST 5520	10Г2 GOST 4543 Group A.Б GOST 550 Group B GOST 8731	Steel 35 GOST 1050, Steel 35X GOST4543, OST 26-2043
Minus 60	0.8 1.0 1.4	3	09Г2C, 10Г2C1 of category 8 GOST 5520	10Г2 GOST 4543 TU 14-3-1128	Steel 09Г2C GOST 19281 Steel 20XH3A, 10Г2 GOST 4543 OST 26-2043

### Notes:

- It is allowed to use forgings made of Gr.20 steel with the thickness in the weld location (butt-welded flanges) being max. 12 mm at down to minus 40°C without heat treatment of the welded joint.
- It is allowed to use pipes with the thickness of max. 12 mm made of steels with grades 10 and 20 per GOST 550, GOST 8731, GOST 8733 at the wall temperature down to minus 40°C.
- Flanges gaskets shall be accepted made of paronite per GOST 481.





# Liquid Strainers for Pipelines

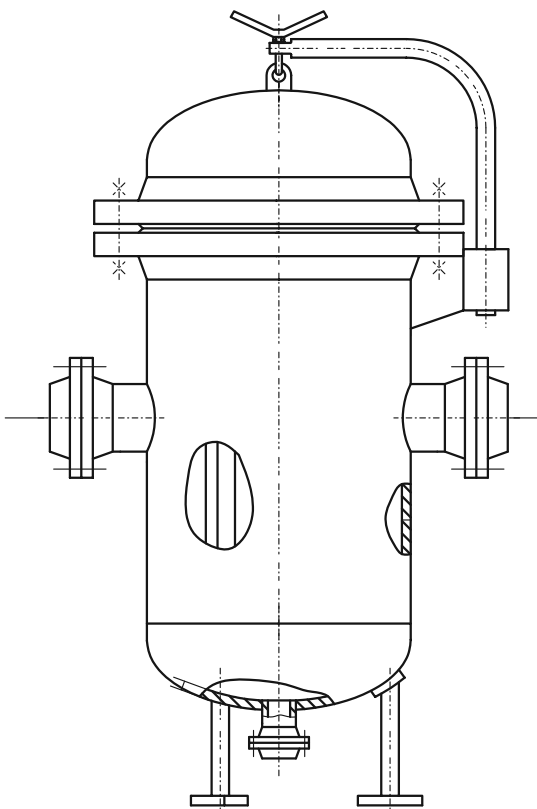

# 113 Liquid Strainers for Pipelines

Liquid strainers are used for pipelines designed for nominal pressure of 1.6 and 4.0 MPa with the transferred liquid temperature between minus 60 and 300°C.

These filters are used for protection of pumping and other equipment in process packages of oil processing, petrochemical, oil and gas industries, operation of which requires that the solid impurities in liquid are, at maximum, 200 µm.

Hazard classes of transferred liquid – 1, 2, 3 and 4 per GOST 12.1.007-76.

Design, parameters and dimensions of strainers are according to ATK 24.218.04-90, GSTU 3-17-207-2000.

Two design makes of strainers are manufactured, per the type of connection with pipelines: make 1 – flanged; make 2 – welded.

Examples of strainers designations when ordering:

- liquid drain strainer (SDJ) installed on a pipeline with nominal diameter (DN) 250 mm, for nominal pressure (PN) 1.6 MPa, design make 2, material make 3:

**Filter SDJ 250-1.6-2-3;**

- same filter under an inter-crystal corrosion (ICC) requirement:

**Filter SDJ 250-1.6-2-3M;**

- same filter with insulation:

**Filter SDJ 250-1.6-2-3И;**

- same filter under an ICC requirement with insulation:

**Filter SDJ 250-1.6-2-3ИИ;**

- same filter in export make:

**Filter SDJ 250-1.6-2-3Э.**

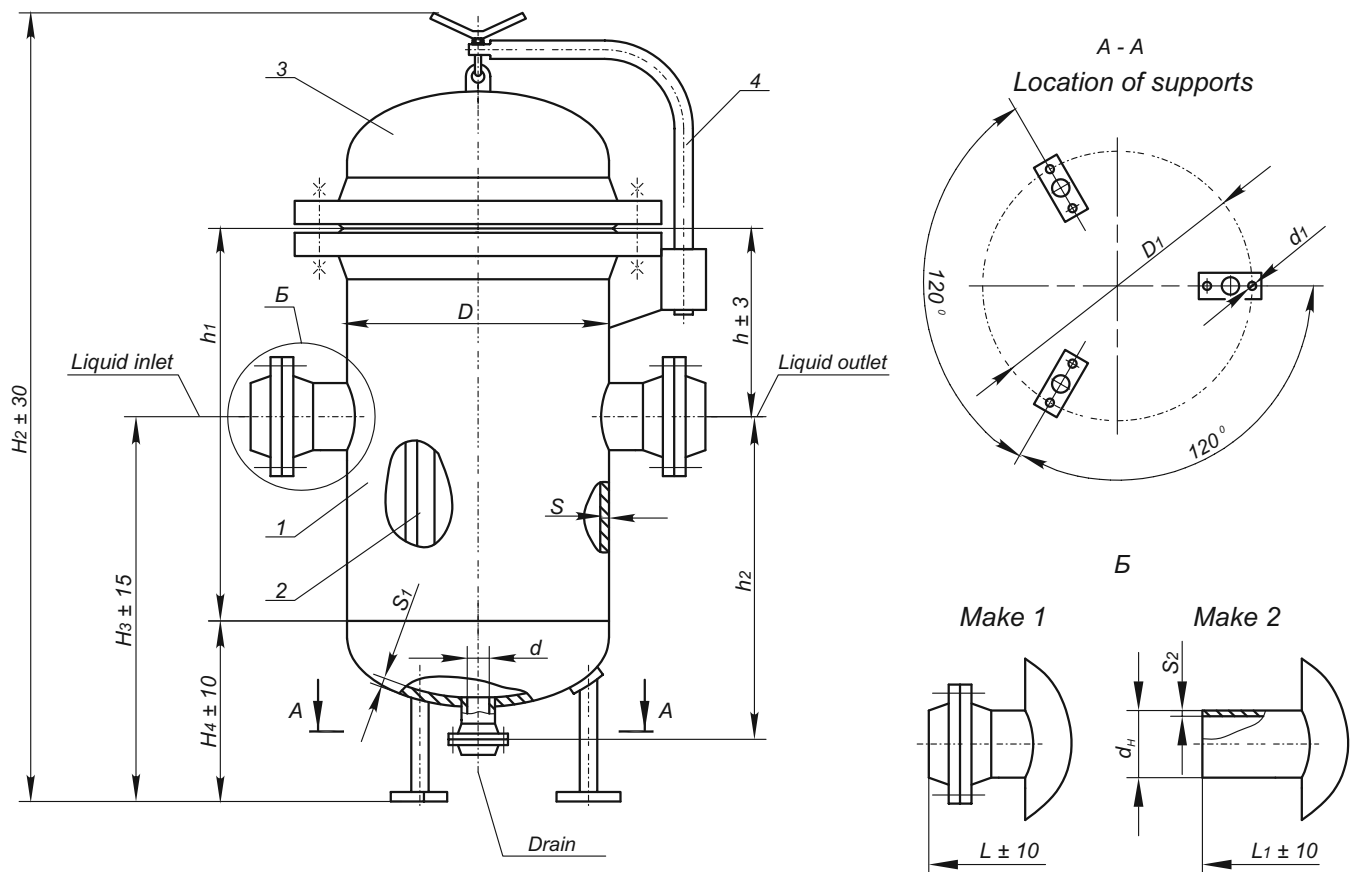

- 1 – Shell
- 2 – Filter element
- 3 – Cover
- 4 – Lifting and turning device



# 114 Liquid Strainers for Pipelines

Filters sizes and parameters

Table 6.1

DN		80	150	250	300	500	80	150	
PN, MPa		1.6			4.0				
D		273	426	630	630	1028	273	426	
d <sub>H</sub>		89	159	273	325	530	89	159	
d		50	50	100	100	100	50	50	
h		230	320	400	400	650	260	345	
h <sub>1</sub>		465	770	1090	1090	1400	465	770	
h <sub>2</sub>		485	740	1040	1040	1215	455	715	
S		7 (6)	9 (8)	10	10	14	7 (6)	10	
S <sub>1</sub>		6	8 (6)	10	10	14	8	10	
S <sub>2</sub>		5	6	10	10	14	8	12	
L		730 (720)	1005 (995)	1255	1325	1920	760 (750)	1090	
L <sub>1</sub>		420 (410)	650 (640)	850	910	1360	420 (410)	650	
Volume, m <sup>3</sup>		0.03	0.11	0.41	0.41	1.45	0.03	0.14	
Filtration area, m <sup>2</sup> , at least		0.18	0.60	1.53	1.53	3.08	0.18	0.60	
Weight, kg	Design make	1	112 (110)	272 (260)	537	575	1620	165 (163)	390
		2	96 (94)	234 (222)	475	482	1340	146 (144)	337

DN	Designation of support ATK 24.200.0390	D <sub>1</sub>	d <sub>1</sub>	H <sub>2</sub>	H <sub>3</sub>	H <sub>4</sub>
250, 300	2-10	640	19	2245	1230	450
500	2-25	980	24	2750	1370	600

Filter usage limits

Table 6.2

DN	PN, MPa	Material make code	Operating (design) pressure, MPa, at temperature °C, max			
			100	200	250	300
80	1.6	1, 2	1.60	1.60	1.40	1.20
150				1.50	1.44	1.33
250						
300						
500						
80	1.6	3	1.60	1.60	1.50	1.40
150				1.49	1.44	1.38
250						
300						
80	4.0	1, 2	4.0	4.0	3.50	3.0
150				3.74	3.60	3.34
80						
150						
80	4.0	3	4.0	4.0	3.75	3.50
150				3.72	3.60	3.44



# 115 Liquid Strainers for Pipelines

**Notes:**

1. Actual operating pressure values shall be below the ones in the table by the value, by which the design pressure is higher than the operating pressure, stipulated by norms of the industry, in which the strainer will be used.
2. Actual operating pressure values shall be stated by the consumer in the passport in the "Other data on the vessel installation" section.

3. The first stage of operating pressure at 100°C covers minus temperatures as well, but not lower than temperature limits acceptable for steels per SOU MPP 71.120-217:2009, GOST R 52630 and CU TR032/2013.

**Material make of strainers**

Table 6.3

Name of assembly unit, part	Material make code		
	1	2	3
	Transferred liquid temperature, °C		
	from minus 30 to 300	from minus 60 to 300	from minus 40 to 300
	Steel grade, standard designation		
shell	20 GOST8731 09Г2С-12 GOST 5520	10Г2 GOST8731	12X18H10T GOST9940 GOST9941 12X18H10T GOST7350
head	09Г2С-12 GOST5520	09Г2С-14 GOST5520	12X18H10T GOST7350
flanges	20 GOST8479 group IV КП215	10Г2 GOST8479 group IV КП215	12X18H10T GOST25054 group IV
nozzles	20 GOST873 09Г2С-12 GOST5520	10Г2 GOST8731 09Г2С-14 GOST5520	12X18H10T GOST9940 GOST9941 12X18H10T GOST7350
supports	Ст3пс2 GOST14637	09Г2С-14 GOST5520	12X18H10T GOST9940
gaskets	Paronite GOST481		
filter element sealing	Inter-braided packing, APS mark, GOST5152		



# Gas and Oil Separators

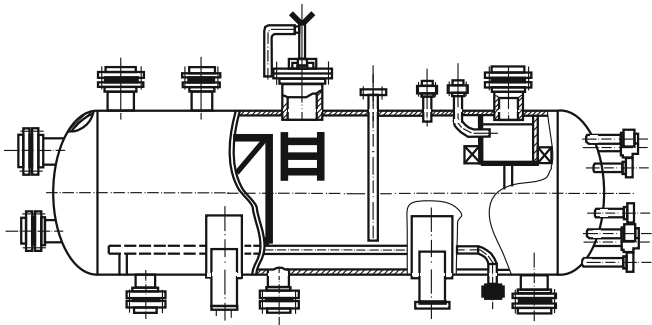

Gas and oil separators (GOS, or NGS) are intended for non-foamy oil degassing and associated gas cleaning at the inlet, intermediate and final stages of industrial packages for collecting and preparing the oil and gas fields products for operation in the moderate and moderate-cold climatic conditions with the air temperature during operation:

- for moderate climate – from plus 40°C to minus 40°C;
- for moderate-cold climate – from plus 40°C to minus 60°C.

NGS gas and oil separators are used in areas with the seismic activity value of up to and including 6.

Design-wise, the NGS gas and oil separators are classified as:

- type I – used in configuration with slug catcher subassemblies (pulsation bottles);
- type I-Π – used in configuration with slug catcher subassemblies with a defoaming cap;
- type II – used without slug catcher sub-assemblies;
- type II-Π – used without slug catcher sub-assemblies, with a defoaming cap.

Depending on the operation conditions, NGS gas and oil separators are manufactured with and without heat treatment, with and without heat insulation fasteners.

When ordering a gas and oil separator with heat treatment, the customer shall submit an arrangement diagram for maintenance platforms fastening.

Volumetric oil output is between 20 and 2250 m<sup>3</sup>/h, and gas output – between 20700 and 440000 m<sup>3</sup>/h.

Gas and oil separators are manufactured having the volume of 6.3; 12.5; 25; 50; 100, 150 m<sup>3</sup> and the nominal pressure of 0.6; 1.0; 1.6; 2.5; 4.0; 6.3\* MPa. Operating temperature between 0 and 100°C.

The type of flanges' sealing surfaces is discussed when ordering a separator.

Per customer requirement and agreement with design organization, it is possible to alter the design of a gas and oil separator, including the aspects of installing additional internals and changing the nozzles arrangement for a specific technological process.

Designation of a gas and oil separator:

**NGS-T-Π-P-D-M-И,**

where:

T – Type (I, II);

Π – Presence of a defoaming cap;

P – Design pressure in MPa;

D – Internal diameter in mm;

M – Material make (1, 2);

И – Presence of heat insulation.

Designation examples:

Type I separator for design pressure of 2.5 MPa, with the diameter of 2400 mm, material make 1:

**Separator NGS-I-2.5-2400-1.**

Same, with a defoaming cap:

**Separator NGS-I-Π-2.5-2400-1.**

Type II separator for design pressure of 1,0 MPa, with the diameter of 1200 mm, material make 2, with a defoaming cap and heat treatment:

**Separator NGS-II-Π-1.0-1200-2-T.**

Same, with heat insulation supports:

**Separator NGS-II-Π-1.0-1200-2-T-И.**

\* Per the customer requirements, it is possible to manufacture NGS separators with nominal pressure higher than stated.



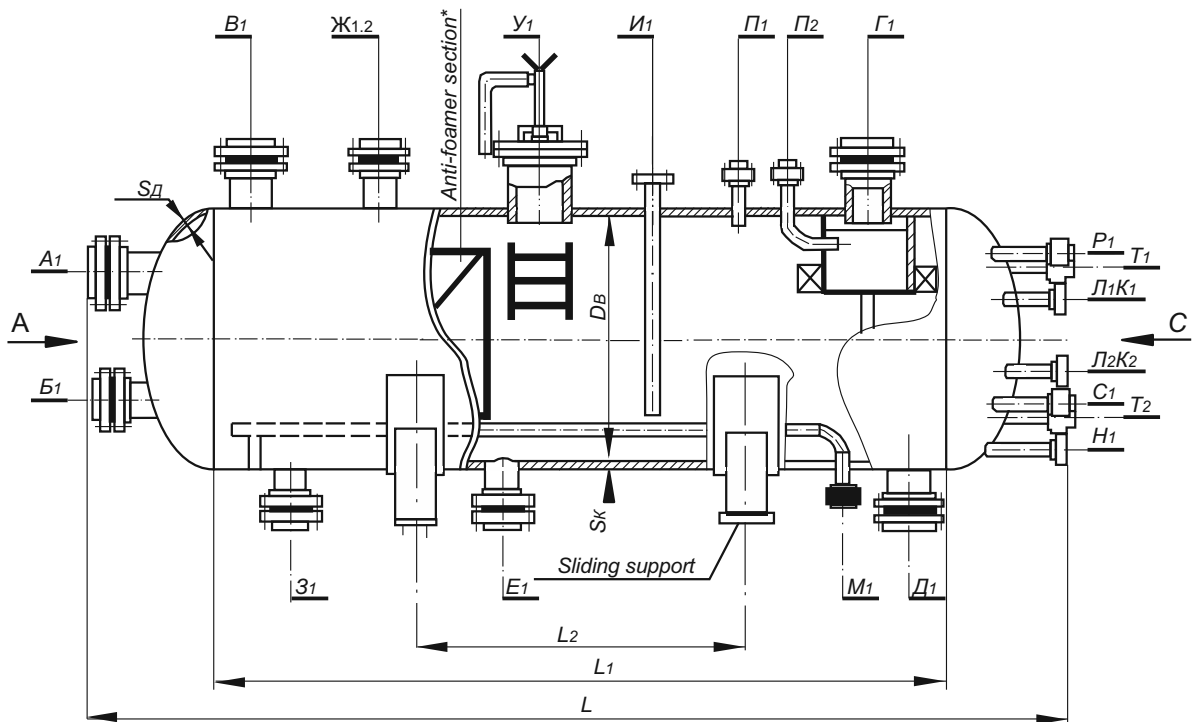

Nozzle B1 only for I and I-II type

View A

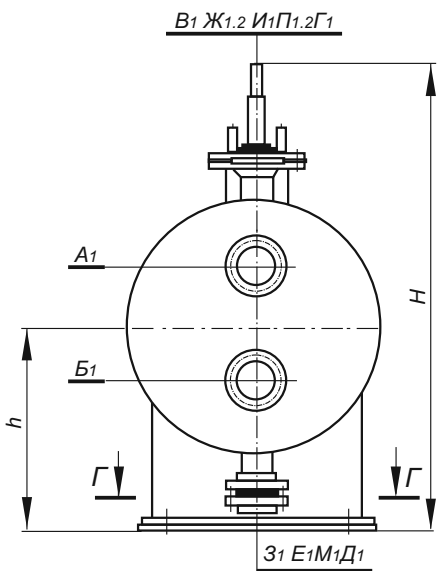

For apparatuses  $\varnothing$  1200, 1600

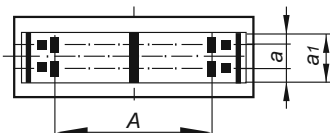

View C

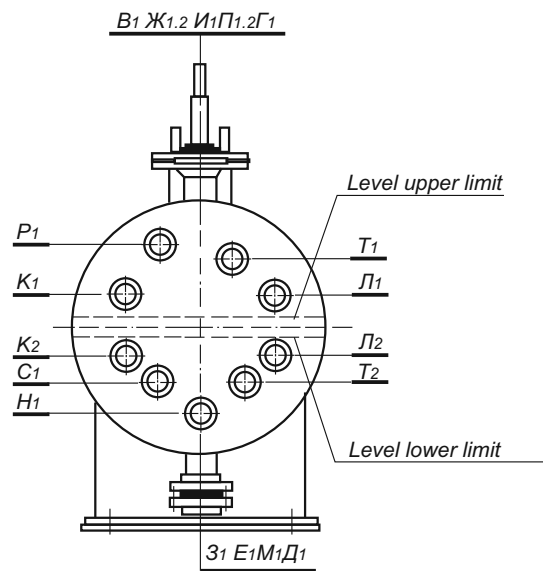

For apparatuses  $\varnothing$  2000, 2400, 3000, 3400

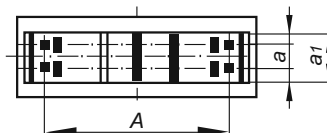

Г-Г



Technical characteristics of NGS-I, NGS-II gas and oil separators

Table 7.1

ID code of apparatuses	Volume, m <sup>3</sup>	Pressure, MPa		H, mm	h, mm	No of demisters, $\square$	D <sub>B</sub> , mm	S <sub>k</sub> , S <sub>d</sub> , mm	L, mm	L <sub>1</sub> , mm	L <sub>2</sub> , mm	Volumetric output		Mass, kg**			
		operating	rated									oil-wise, m <sup>3</sup> /h	gas-wise, nm <sup>3</sup> /h*	Type I	Type II	Type I-Π	Type II-Π
NGS-0.6-1200	6.3	0.4	0.6	2173	818	8	1200	8	6511	5400	3000	20±100	20700	Type I	Type II	Type I-Π	Type II-Π
NGS-1.0-1200		0.8	1.0	2173	818			8	6511					2690	2640	2800	2750
NGS-1.6-1200		1.4	1.6	2177	820			10	6545					3090	3030	3200	3140
NGS-2.5-1200		2.2	2.5	2181	822			12	6567					3690	3590	3800	3700
NGS-4.0-1200	6.3	3.6	4.0	2281	828	18	6604	5090	4980	5200	5090	55000	55000	5090	4980	5200	5090
NGS-6.3-1200		5.7	6.3	2428	838	25	6758	6690	6520	6800	6630	74900	74900	6690	6520	6800	6630
NGS-0.6-1600	12.5	0.4	0.6	2743	1018	8	1600	8	8190	6800	4300	45±225	41400	Type I	Type II	Type I-Π	Type II-Π
NGS-1.0-1600		0.8	1.0	2743	1018			8	8190					4314	4178	4578	4446
NGS-1.6-1600		1.4	1.6	2751	1022			12	8220					5560	5536	5934	5795
NGS-2.5-1600		2.2	2.5	2759	1026			16	8221					7140	6970	7399	7229
NGS-4.0-1600	12.5	3.6	4.0	2891	1032	22	8361	9763	9540	10022	9829	110000	110000	9763	9540	10022	9829
NGS-6.3-1600		5.7	6.3	2842	1042	32	8417	13500	13200	13870	13570	149500	149500	13500	13200	13870	13570
NGS-0.6-2000	25	0.4	0.6	2893	1210	8	2000	8	10101	8500	5000	86±430	62200	Type I	Type II	Type I-Π	Type II-Π
NGS-1.0-2000		0.8	1.0	2897	1212			10	10104					6429	6185	7291	7047
NGS-1.6-2000		1.4	1.6	2901	1214			12	10133					7630	7360	8540	8260
NGS-2.5-2000		2.2	2.5	2913	1220			18	10211					8440	8170	9350	9070
NGS-4.0-2000	25	3.6	4.0	3013	1227	25	10320	11610	11230	12510	12040	165000	165000	11610	11230	12510	12040
NGS-6.3-2000		5.7	6.3	3057	1251	45	10452	16080	15630	16980	16530	224800	224800	16080	15630	16980	16530





Table 7.1 (cont.)

ID code of apparatuses	Volume, m <sup>3</sup>	Pressure, MPa		H, mm	h, mm	No of demisters	D <sub>B</sub> , mm	S <sub>K</sub> , S <sub>d</sub> , mm	L, mm	L <sub>1</sub> , mm	L <sub>2</sub> , mm	Volumetric output		Mass, kg**			
		operating	rated									oil-wise, m <sup>3</sup> /h	gas-wise, nm <sup>3</sup> /h*	Type I	Type II	Type I-Π	Type II-Π
NGS-0.6-2400	50	0.4	0.6	3545	1420	32	2400	8	12889	11000	6000	160÷800	82900	Type I	Type II	Type I-Π	Type II-Π
NGS-1.0-2400		0.8	1.0	3547	1420			10	12893					10660	10310		
NGS-1.6-2400	50	1.4	1.6	3555	1424	32	2400	14	12944	11000	6000	160÷800	125500	11240	10880	12543	12183
NGS-2.5-2400		2.2	2.5	3571	1432			20	12964					15448	14950		
NGS-4.0-2400	50	3.6	4.0	3687	1440	32	2400	30	13128	11000	6000	160÷800	156300	19760	19240	21063	20543
NGS-0.6-3000		0.4	0.6	3909	1726			10	15215					16290	19200		
NGS-1.0-3000	100	0.8	1.0	3917	1730	48	3000	12	15229	13000	8000	300÷1500	140000	18210	17740	22050	21580
NGS-1.6-3000		1.4	1.6	3931	1738			18	15241					19990	23830		
NGS-2.5-3000	100	2.2	2.5	3945	1745	48	3000	25	15320	13000	8000	300÷1500	234000	36110	35670	39097	38657
NGS-4.0-3000		3.6	4.0	4055	1760			40	15515					56897	55727		
NGS-0.6-3400	150	0.4	0.6	4306	1923	64	3400	12	17770	15300	9000	450÷2250	165000	24591	24041	28449	27899
NGS-1.0-3400		0.8	1.0	4312	1927			14	17774					30560	34390		
NGS-1.6-3400	150	1.4	1.6	4328	1933	64	3400	20	17826	15300	9000	450÷2250	251000	41090	40100	44920	43930
NGS-2.5-3400		2.2	2.5	4344	1941			28	17872					55260	59100		
NGS-4.0-3400	150	3.6	4.0	4358	1963	64	3400	50	18061	15300	9000	450÷2250	449000	98100	95750	101958	99608

\* Gas output is stated under normal conditions: pressure P=0,1013 MPa and temperature t=0°C.

\*\* Mass is further specified per the results of detailed design.



Nozzles table

Table 7.2

ID code of apparatuses	Designation and function																	
	A1	Б1*	В1*	Г1	Д1	Е1	Ж1,2	З1	И1	К1,2	Л1,2	М1	Н1	П1,2	Р1	С1	Т1,2	У1
	Oil-gas mixture inlet	Oil inlet	Gas inlet	Gas outlet	Oil outlet	For cleaning	For safety valve	For drain	For level gauge installation	For level regulator	For level alarm	For steaming	For mercury-type thermometer	For diff. pressure gauge	For pressure gauge	For resistance thermometer	For level indicator	Access manhole
	PN, MPa	PN, MPa	PN, MPa	PN, MPa	PN, MPa	PN, MPa	PN, MPa	PN, MPa	PN, MPa	PN, MPa	PN, MPa	PN, MPa	PN, MPa	PN, MPa	PN, MPa	PN, MPa	PN, MPa	PN, MPa
	DN	DN	DN	DN	DN	DN	DN	DN	DN	DN	DN	DN	DN	DN	DN	DN	DN	DN
NGS-0.6-1200	1.6	1.6	1.6	1.6	1.6	1.6	1.6	1.6	1.6	1.6	1.6	1.6	1.6	1.6	1.6	1.6	1.6	2.5
NGS-1.0-1200	2.5	2.5	2.5	2.5	2.5	2.5	2.5	2.5	2.5	2.5	2.5	2.5	2.5	2.5	2.5	2.5	2.5	4.0
NGS-1.6-1200	4.0	4.0	4.0	4.0	4.0	4.0	4.0	4.0	4.0	4.0	4.0	4.0	4.0	4.0	4.0	4.0	4.0	6.3
NGS-2.5-1200	6.3	6.3	6.3	6.3	6.3	6.3	6.3	6.3	6.3	6.3	6.3	6.3	6.3	6.3	6.3	6.3	6.3	15
NGS-4.0-1200																		500
NGS-6.3-1200																		6.3
NGS-0.6-1600	1.6	1.6	1.6	1.6	1.6	1.6	1.6	1.6	1.6	1.6	1.6	1.6	1.6	1.6	1.6	1.6	1.6	2.5
NGS-1.0-1600	2.5	2.5	2.5	2.5	2.5	2.5	2.5	2.5	2.5	2.5	2.5	2.5	2.5	2.5	2.5	2.5	2.5	4.0
NGS-1.6-1600	4.0	4.0	4.0	4.0	4.0	4.0	4.0	4.0	4.0	4.0	4.0	4.0	4.0	4.0	4.0	4.0	4.0	6.3
NGS-2.5-1600	6.3	6.3	6.3	6.3	6.3	6.3	6.3	6.3	6.3	6.3	6.3	6.3	6.3	6.3	6.3	6.3	6.3	15
NGS-4.0-1600																		500
NGS-6.3-1600																		6.3

Nominal pressures and diameters



Table 7.2 (cont.)

ID code of apparatuses	Designation and function																		
	A1	Б1*	В1*	Г1	Д1	Е1	Ж1,2	З1	И1	К1,2	Л1,2	М1	Н1	П1,2	Р1	С1	Т1,2	У1	
	Oil-gas mixture inlet	Oil inlet	Gas inlet	Gas outlet	Oil outlet	For cleaning	For safety valve	For drain	For level gauge installation	For level regulator	For level alarm	For steaming	For mercury-type thermometer	For diff. pressure gauge	For pressure gauge	For resistance thermometer	For level indicator	Access manhole	
	DN	DN	DN	DN	DN	DN	DN	DN	DN	DN	DN	DN	DN	DN	DN	DN	DN	DN	PN, MPa
NGS-0.6-2000	1.6	1.6	1.6	1.6	1.6	1.6	1.6	1.6	1.6	1.6	1.6	1.6	1.6	1.6	1.6	1.6	1.6	1.6	2.5
NGS-1.0-2000	2.5	2.5	2.5	2.5	2.5	2.5	2.5	2.5	2.5	2.5	2.5	2.5	2.5	2.5	2.5	2.5	2.5	2.5	4.0
NGS-1.6-2000	4.0	4.0	4.0	4.0	4.0	4.0	4.0	4.0	4.0	4.0	4.0	4.0	4.0	4.0	4.0	4.0	4.0	4.0	6.3
NGS-2.5-2000	6.3	6.3	6.3	6.3	6.3	6.3	6.3	6.3	6.3	6.3	6.3	6.3	6.3	6.3	6.3	6.3	6.3	6.3	15
NGS-4.0-2000																			500
NGS-6.3-2000																			6.3
NGS-0.6-2400																			6.3
NGS-1.0-2400	1.6	1.6	1.6	1.6	1.6	1.6	1.6	1.6	1.6	1.6	1.6	1.6	1.6	1.6	1.6	1.6	1.6	1.6	2.5
NGS-1.6-2400	4.0	4.0	4.0	4.0	4.0	4.0	4.0	4.0	4.0	4.0	4.0	4.0	4.0	4.0	4.0	4.0	4.0	4.0	6.3
NGS-2.5-2400	2.5	2.5	2.5	2.5	2.5	2.5	2.5	2.5	2.5	2.5	2.5	2.5	2.5	2.5	2.5	2.5	2.5	2.5	4.0
NGS-4.0-2400	4.0	4.0	4.0	4.0	4.0	4.0	4.0	4.0	4.0	4.0	4.0	4.0	4.0	4.0	4.0	4.0	4.0	4.0	6.3

Nominal pressures and diameters



Table 7.2 (cont.)

ID code of apparatuses	Designation and function																	
	A <sub>1</sub>	B <sub>1</sub> *	B <sub>1</sub> *	Г <sub>1</sub>	Д <sub>1</sub>	Е <sub>1</sub>	Ж <sub>1,2</sub>	З <sub>1</sub>	И <sub>1</sub>	К <sub>1,2</sub>	Л <sub>1,2</sub>	М <sub>1</sub>	Н <sub>1</sub>	П <sub>1,2</sub>	Р <sub>1</sub>	С <sub>1</sub>	Т <sub>1,2</sub>	У <sub>1</sub>
	Oil-gas mixture inlet	Gas inlet	Gas outlet	Oil outlet	For cleaning	For safety valve	For drain	For level gauge installation	For level regulator	For level alarm	For steaming	For mercury-type thermometer	For diff. pressure gauge	For pressure gauge	For resistance thermometer	For level indicator	Access manhole	
	PN, MPa	DN	PN, MPa	DN	PN, MPa	DN	PN, MPa	DN	PN, MPa	DN	PN, MPa	DN	PN, MPa	DN	PN, MPa	DN	PN, MPa	DN
NGS-0.6-3000	1.6	500	1.6	500	300	200	150	65	4.0	50	4.0	50	4.0	25 M20x1.5	1.6	25	600	2.5
NGS-1.0-3000	2.5	500	1.6	500	300	200	150	65	4.0	50	4.0	50	4.0	25 M20x1.5	2.5	25	600	2.5
NGS-1.6-3000	4.0	500	1.6	500	300	200	150	65	4.0	50	4.0	50	4.0	25 M20x1.5	4.0	25	600	4.0
NGS-2.5-3000	4.0	500	1.6	500	300	200	150	65	4.0	50	4.0	50	4.0	25 M20x1.5	4.0	25	600	4.0
NGS-4.0-3000	4.0	500	1.6	500	300	200	150	65	4.0	50	4.0	50	4.0	25 M20x1.5	4.0	25	600	4.0
NGS-0.6-3400	1.6	600	1.6	600	300	200	150	65	4.0	50	4.0	50	4.0	25 M20x1.5	1.6	25	600	2.5
NGS-1.0-3400	2.5	600	1.6	600	300	200	150	65	4.0	50	4.0	50	4.0	25 M20x1.5	2.5	25	600	2.5
NGS-1.6-3400	4.0	600	1.6	600	300	200	150	65	4.0	50	4.0	50	4.0	25 M20x1.5	4.0	25	600	4.0
NGS-2.5-3400	4.0	600	1.6	600	300	200	150	65	4.0	50	4.0	50	4.0	25 M20x1.5	4.0	25	600	4.0
NGS-4.0-3400	4.0	600	1.6	600	300	200	150	65	4.0	50	4.0	50	4.0	25 M20x1.5	4.0	25	600	4.0

\*Nozzles B<sub>1</sub> and B<sub>1</sub> are not present in the gas and oil type II gas separator structure.



Table 7.3

Names of assembly units and parts of gas and oil separators		Make per materials		
		1	2	
		Average temperature of the coldest five-days period, °C		
		down to minus 40	down to minus 60	
Material grade, designation of standards				
Shell, heads, support plates		Steel 09Г2С-6 GOST 5520	Steel 09Г2С-8 GOST 5520	
Supports		Ст3пс4 GOST 14637	Steel 09Г2С-8 GOST 5520	
Flanges		Steel 20 GOST 1050 Steel 09Г2С GOST19281 Steel 10Г2 GOST 4543 gr. IV GOST 8479	Steel 09Г2С GOST19281 Steel 10Г2 GOST 4543 gr. IV GOST 8479	
Nozzles		Steel 09Г2С-6 GOST 5520 Steel 20 GOST 1050 gr. B GOST 8731 gr. A. Б GOST 550 Steel 10Г2 GOST 4543 gr. IV ГOCT 8479	Steel 09Г2С-8 Steel 10Г2 GOST 4543 gr. B GOST 8731 gr. A. Б GOST 550 Steel 10Г2 GOST 4543 gr. IV GOST 8479	
Plugs		Steel 09Г2С-6 GOST 5520	Steel 09Г2С-8 GOST 5520	
Gaskets of nozzles, manholes		Paronite per GOST 481, spiral-wound per OST26-260-454		
Gaskets of internals		Paronite per GOST 481		
Internals	String-type demister	Steel 09Г2С-6 GOST5520	Steel 09Г2С-8 GOST5520	
	Defoaming cap	Steel 09Г2С-8 GOST 5520 Steel 08X13-M3a GOST 5582		
	Vertical baffles	Ст3пс4 GOST 14637 Expanded steel sheet 510 TS 36.26.11-5-89		
	Parts and assembly units	Ст3пс4 GOST 14637 Steel 09Г2С-6 GOST 5520	Steel 09Г2С-8 GOST 5520	
Fasteners	for nozzles, manhole	Studs	Steel 35 GOST 1050 Steel 35X, 38XA GOST 4543 OST 26-2043	Steel 20XH3A, 35X, 38XA OST 26-2043
		Nuts	Steel 25, Steel 35 GOST 10580 OST 26-2043 Steel 35X, 38XA GOST 4543 OST 26-2043	Steel 20XH3A, 35X, 10Г2, 35X, 38XA GOST 4543 OST 26-2043
	for internals	Bolts	Steel 35 GOST 1050 Steel 35X GOST 4543	Steel 10Г2 GOST 4543
		Nuts	Steel 20, 25, 35 GOST 1050	Steel 10Г2 GOST 4543



Per the agreement with the customer, it is possible to use other materials stated in the mandatory annexes to SOU MPP 71.120-217:2009 and GOST R 52630 in accordance with the limits of their application.

The choice of the paronite grade, filling material of spiral-wound gaskets is carried out depending on the conditions of operation (operating medium, design temperature and pressure).

Fasteners made of 35X, 38XA steels for material make 2 shall be impact-bending tested on V-notch Sharpy specimens under the temperature of minus 60°C. The impact resilience value on all the specimens shall be at least 30 J/cm<sup>2</sup> (3 kgf/cm<sup>2</sup>).

### Main dimensions of support assembly units of gas and oil separators

Table 7.4

Code of the apparatus	Main dimensions of supports, mm		
	A	a	a <sub>1</sub>
NGS-0.6-1200	800	140	250
NGS-1.0-1200			
NGS-1.6-1200			
NGS-2.5-1200			
NGS-4.0-1200			
NGS-6.3-1200	1100	200	300
NGS-0.6-1600			
NGS-1.0-1600			
NGS-1.6-1600			
NGS-2.5-1600			
NGS-4.0-1600	1500	200	300
NGS-6.3-1600			
NGS-0.6-2000			
NGS-1.0-2000			
NGS-1.6-2000			
NGS-2.5-2000	1800	200	300
NGS-4.0-2000			
NGS-6.3-2000			
NGS-0.6-2400			
NGS-1.0-2400			
NGS-1.6-2400	2200	200	300
NGS-2.5-2400			
NGS-4.0-2400			
NGS-0.6-3000			
NGS-1.0-3000			
NGS-1.6-3000	2390	200	300
NGS-2.5-3000			
NGS-4.0-3000			
NGS-0.6-3400			
NGS-1.0-3400			
NGS-1.6-3400	2390	200	300
NGS-2.5-3400			
NGS-4.0-3400			



# Multicyclone Separators

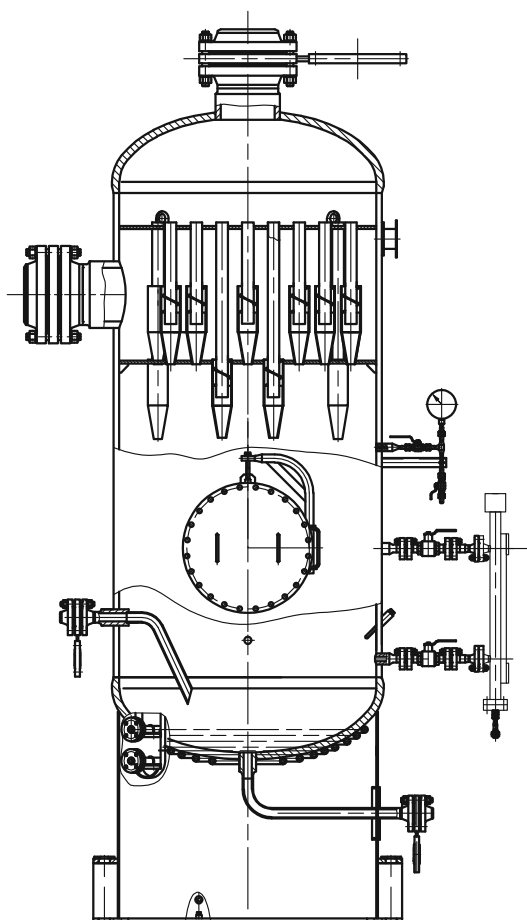

Used for cleaning natural and other gases from liquid drops and mechanical impurities in gas treatment packages, at booster compressor stations and underground gas storages. Separators are manufactured according to SOU MPP 71.120-217:2009, GOST R 52630 and TR TS 032/2013.

The efficiency of gas cleaning from liquid drops and mechanical impurities with the particle size of  $\geq 40 \mu\text{m}$  is at least 99,5%.

The nominal pressure in the apparatus is up to 16 MPa.

Separators are equipped with pre-heaters as per ATK24.218.07-98.

The nominal pressure in the pre-heater is 1.6 MPa.

Separators are used in all macroclimatic areas.

A separator is installed outdoors. Gas goes through a radially positioned nozzle into the cyclone elements battery, where centrifugal forces cause separation into liquid and gas phases. Liquid and mechanical impurities are collected in the cube part of the apparatus and withdrawn through a drain nozzle. Gas is withdrawn from the apparatus through the gas outlet nozzle.

Separator is equipped with instrumentation nozzles and a manhole for control, mode regulation and ease of maintenance.

Separator with the diameter of 800 mm and less are manufactured with a flanged slot in the upper part of the shell.

Separators with the diameter of 1000 mm and more are manufactured as all-welded.

Separators are equipped with devices for heat insulation mounting (per the customer requirement), a verticality checking device, an earthing device.

Depending on the capacity and operating parameters of the apparatus, the type of the cyclone element if chosen and their quantity is determined.

The item includes spectacle blinds, foundation bolts, a set of spare parts.

For ease of installation and maintenance, separators are produced with a valves block regulating the condensate drain out of the apparatus. Depending on the climatic conditions of operation, such a separator is manufactured in packaged or packaged-container make.

A container, in which the valves block is located, is equipped with a gas contamination control and alarm system, combined extract-and-input ventilation system, lighting and heating systems.

Designation example:

**Separator SMC280-635/1.6,**

where

SMC – separator with multicyclone elements;

280 – internal diameter of the apparatus in centimeters;

635 – number of multicyclone elements;

1.6 – design pressure in MPa.

The supply of separators and packaged separators is carried out on the basis of these data sheets of the Customer or the organization performing the project works. The form for the data sheet is provided in the annex.





# 128 Multicyclone Separators

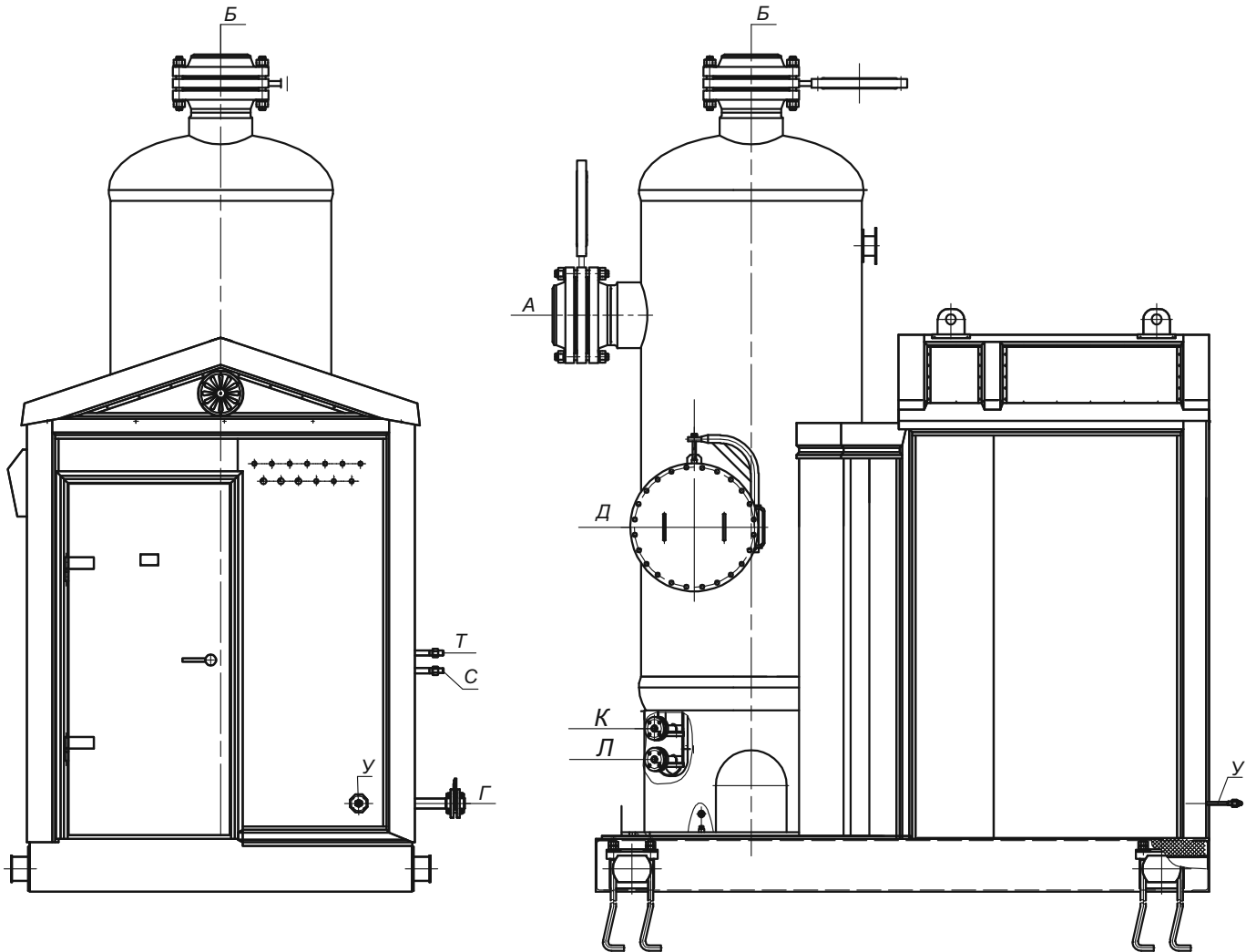

Desig.	Function	Q-ty
A	Gas inlet	1
Б	Gas outlet	1
B	Condensate outlet	1
Г	Drain	1
Д	Manway	1
K	Heat transfer medium inlet	1
Л	Heat transfer medium outlet	1
M	For pressure gauge	1
H1,2	For level gauge	2
П	For level gauge (emergency)	1
P	For thermometer	1
C	For resistance thermometer	1
Ц	Level gauge drain	1
Ю	For thermometer gauge	1
H3	Critical level alarm	1
Y	Instrumentation air feed	1

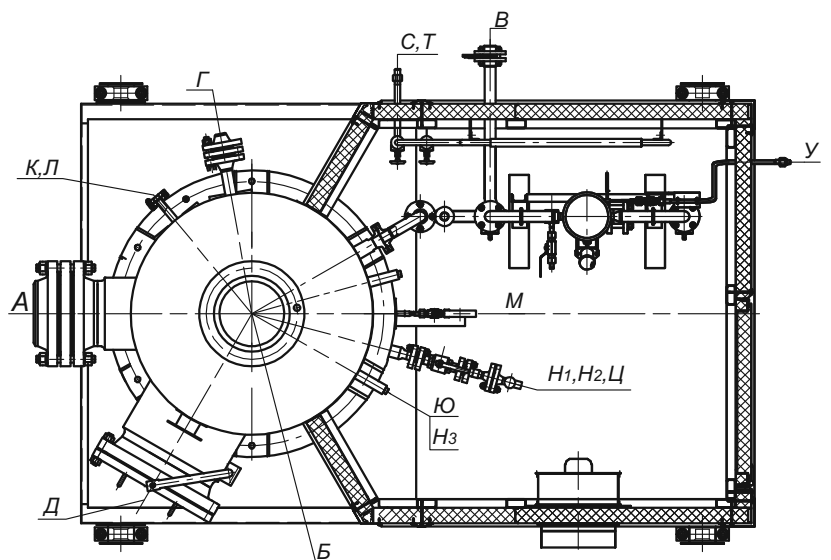

# 129 Multicyclone Separators

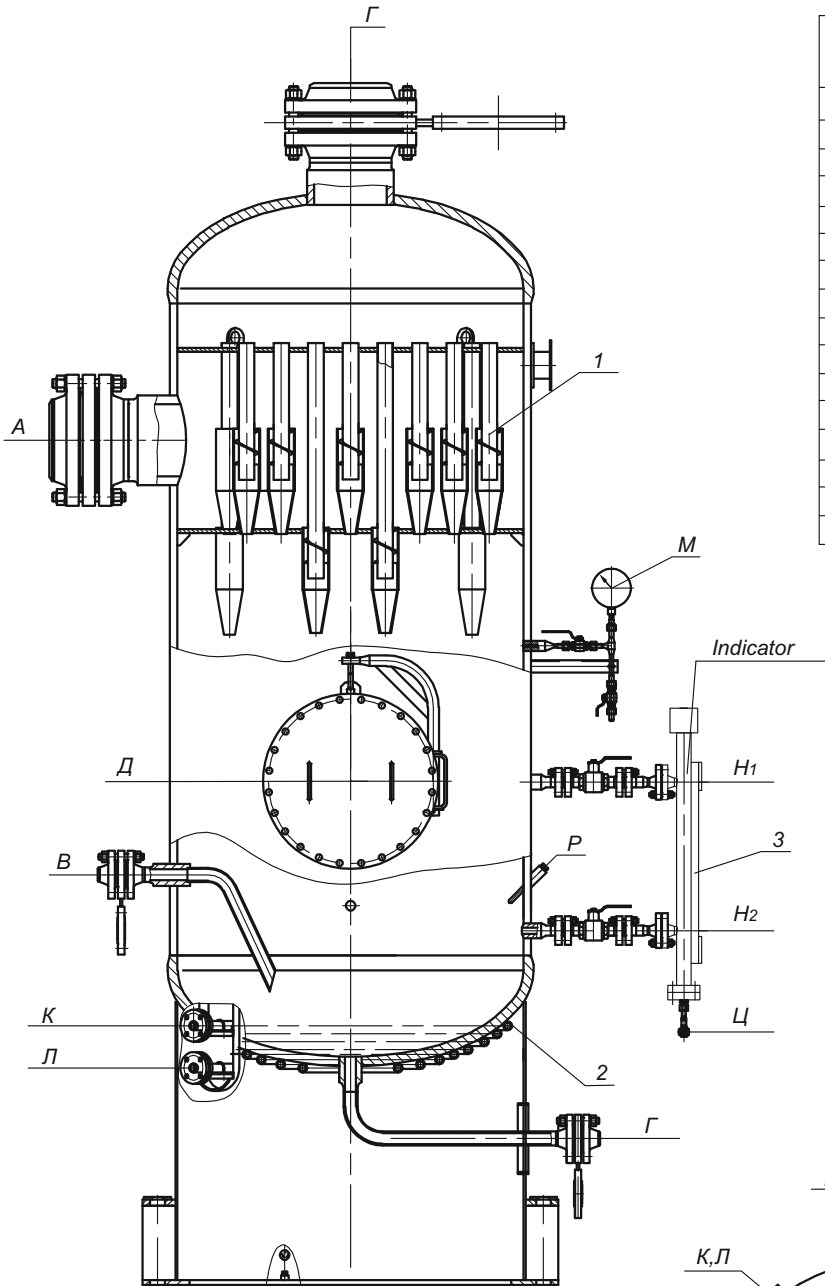

Desig.	Function	Q-ty
А	Gas inlet	1
Б	Gas outlet	1
В	Condensate outlet	1
Г	Drain	1
Д	Manway	1
К	Heat transfer medium inlet	1
Л	Heat transfer medium outlet	1
М	For pressure gauge	1
H1,2	For level gauge	2
П	For level gauge (emergency)	1
Р	For thermometer	1
С	For resistance thermometer	1
Ц	Level gauge drain	1
Ю	For thermometer gauge	1
H3	Critical level alarm	1
У	Instrumentation air feed	1

**Overview of the separator with multicyclones of the SMC type**

- 1 – Centrifugal elements block
- 2 – Pre-heater of the cube part
- 3 – Level regulator (indicator)

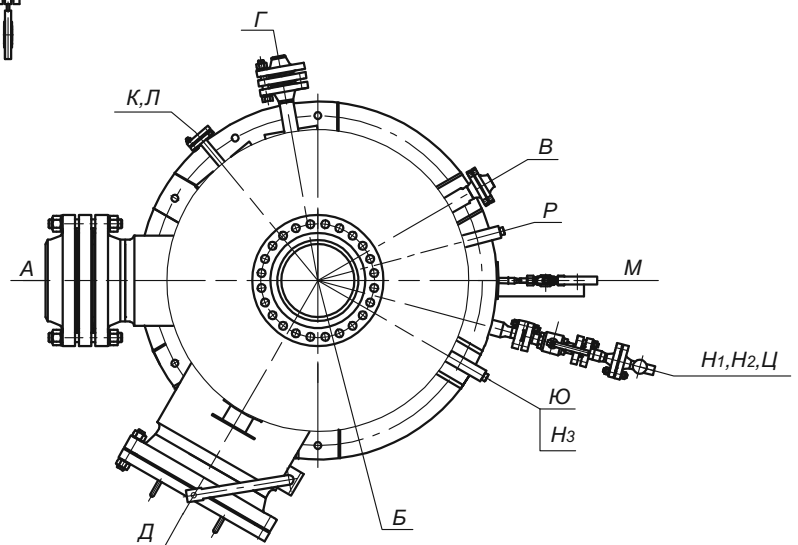

**DATA SHEET No. \_\_\_\_\_  
for separator development**

Purpose of the apparatus

Questions	Answers			
<b>OPERATION PARAMETERS AND CHARACTERISTICS OF THE ITEM</b>				
Gas output on the inlet under $t=0^{\circ}\text{C}$ , $P=0.1013\text{ MPa}$ , $\text{m}^3/\text{h}$ at nominal operating parameters, $\text{m}^3/\text{h}$ possible deviations, %				
Gauge operating pressure of the technological process, MPa possible deviations, MPa				
Operating temperature, $^{\circ}\text{C}$ possible deviations, $^{\circ}\text{C}$				
Minimum allowable wall temperature of a pressure apparatus				
Cleaning efficiency	from solid phase the size of	$\mu\text{m}$	%	
	from liquid phase the size of	$\mu\text{m}$	%	
Maximum allowable flow friction, MPa				
of filtering cartridges, as well:	clean			
	dirty			
Back pressure in the relief system, MPa				
Availability of a heating device and its installation location				
List of nozzles, DN and PN				
Availability of insulation				
<b>FLUID CHARACTERISTICS</b>				
Fluid name and its aggressive state				
Size and mass concentration of impurity on the filter inlet (size-consist)	Drops size, $\mu\text{m}$	Concentration, % mass	Particles size, $\mu\text{m}$	Concentration, % mass



# 131 Data Sheet for the Development of a Multicyclone Separator

Questions		Answers	
Amount of particles in gas under operating conditions on the inlet, mg/m <sup>3</sup>	mechanical impurities		
	liquid phase		
Fluid composition	Component	% mol	% mass
Gas density, kg/m <sup>3</sup> : under t=0°C, P=0,1013 MPa at nominal operating parameters			
Density of solids, kg/m <sup>3</sup>			
Kinematic viscosity (at nominal operating parameters), m <sup>2</sup> /s			
Properties of liquid:	density, kg/m <sup>3</sup>		
	viscosity, mPas		
	surface tension force, N/m		
Fire hazard level of medium per GOST 12.1.044-89			
Explosion category of mixture per GOST R51330.11-99			
Explosive mixture group per GOST R51330.5-99			
Hazard class per GOST 12.1.007-76			
Seismicity of the apparatus' installation site, value			
<b>CONTROL AND OPERATION CONDITIONS</b>			
Number of ordered items			
Supply type (package, non-package)			
Structural make: horizontal, vertical			
Intended operating life			
Location of the item			
Location of the technological process control point			
Average temperature of the coldest five-days period, °C			
Absolute minimum ambient air temperature, °C			
Climatic make per GOST15150			



# 132 Data Sheet for the Development of a Multicyclone Separator

Questions	Answers	
Other requirements	Design gauge pressure, Pdes	
	Design wall temperature, tdes	
	Internal diameter of shell, ID	
	Internal volume of the item, m <sup>3</sup>	
	Material: shell internals sealing	
	Corrosion rate, mm/year	
	The need to: weld mounts for maintenance	
	platforms and ladders attachment	
	add maintenance platforms to the supply	
	test for intercrystalline corrosion	
painting requirements		
Post index, post and telegraph address, telephone number of the enterprise, for which the apparatus is ordered		
Post index, post and telegraph address, telephone number of the organization that filled out the data sheet		
<p><b>The data sheet shall be accompanied with sketches of the apparatus' assembly and contain the following data: the quantity, location, function and size of nozzles, bosses, manholes and liners for instrumentation, specification for all included valves and instrumentation.</b></p>		



# Columns

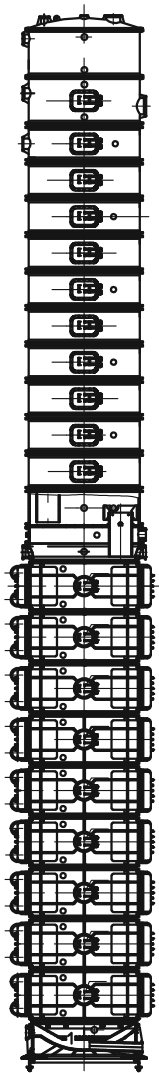
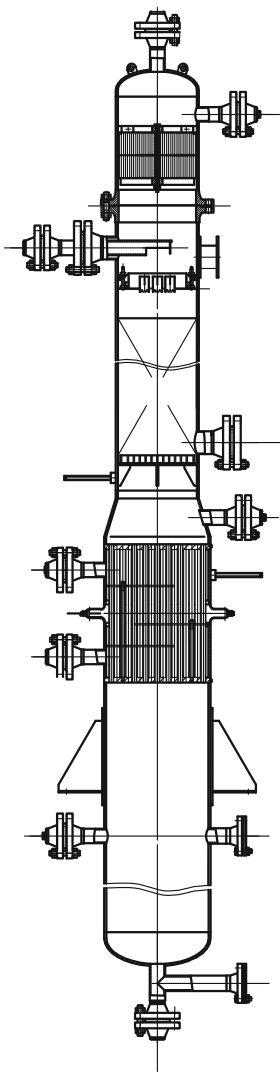

Columns are used for heat- and mass-transfer processes: rectification, absorption, distillation, adsorption etc. in various branches of industry.

The Company manufactures an entire spectrum of columns, stipulated by the following normative basis:

SOU MPP 71.120-217:2009 "Steel welded vessels and apparatuses";

GOST R 52630 "Steel welded vessels and apparatuses";

OST 26-01-151-82 "Steel welded vessels and apparatuses for low-temperature gas separation";

STO 00220575.063-2005 "Vessels, apparatuses and process blocks of treatment and processing packages for oil and gas containing hydrocarbon and causing hydrocarbon cracking";

OST 26-01-382-79 "Cast iron column apparatuses";

TR TS 032/2013 Technical regulation of the Customs Union "On the safety of equipment operating under excessive pressure".

Columns are installed indoors or outdoors with the average temperature of the coldest five-days period down to minus 60°C and seismicity value up to VIII. Climatic make of the columns is according to GOST 15150-69.

Columns are manufactured for operation under vacuum pressure (with the residual pressure of at least 665 Pa (5 mm Hg), under atmospheric pressure and under the pressure above atmospheric up to 16 MPa (160 kgf/cm<sup>2</sup>), with the operating medium temperature of up to 350°C.

Depending on the production capacity and technological process, it is possible to manufacture columns from Ø600 mm to Ø4000 mm according to GOST21944-76 with complete factory assembly, more than Ø4000 mm with additional assembly at the installation site (due to transportation conditions). The height of the column is determined by the design quantity of mass-transferring devices. The shell and internals materials are chosen based on corrosion resistance to the processed product. The type of internals is chosen during the process design.

The enterprise possesses the technological capabilities for designing and manufacturing the following types of trays:

1. Bubble-cap trays per OST 26-01-66-86 with caps per GOST 9634-80.

2. Direct-flow valve collars per ATK26-02-1-89.

3. Multi-flow valve collars ATK26-02-2-89 and ATK26-02-4-89.

4. Sieve-valve collars per OST26-01-108-85.

5. Sieve trays per ATK26-02-3-39.

6. Grid trays per OST26-645-78.

7. Distributor trays per OST26-01-705-73 for packed columns.

Trays are made of steels Ст3сп; Ст3пс per GOST380-88; 08X13; 08X18H10T; 10X17H13M2T and others per GOST5632-72, as well as titanium and Hastelloy.

It is possible to use other steels, justified by the corrosion resistance to the processed medium.

The following packing types are used for packaging of packed columns: rhomboid, plane-parallel, Pall rings, Raschig rings, and others chosen by the design organization.

When ordering a column, a customer needs to submit a filled-out data sheet (see the Annex), on the basis of which the process and strength design will be carried out. According to the design, the internals type and the most optimal column dimensions will be determined. In order to increase the technical and economic parameters, the columns are equipped, besides mass-transferring devices, with additional components reducing product entrainment on the outlet, load-lifting devices, instrumentation, ladders and maintenance platforms for manholes and process nozzles.

Columns are mounted on support legs per GOST 26296-84 for installation on bridgings of metal structures, as well as on cylindrical or conical vertical supports per ATK24.200.04-90.

During the manufacture, calculations are done for the columns with regard to strength, seismic and wind load resistance. The calculations are attached to the vessel's passport.

Per the Customer's requirement, columns are packaged with a jib-crane with the lifting capacity of up to 1 tf.

The following are the sketches of typical columns manufactured at the enterprise.



# 135 Stripping Columns

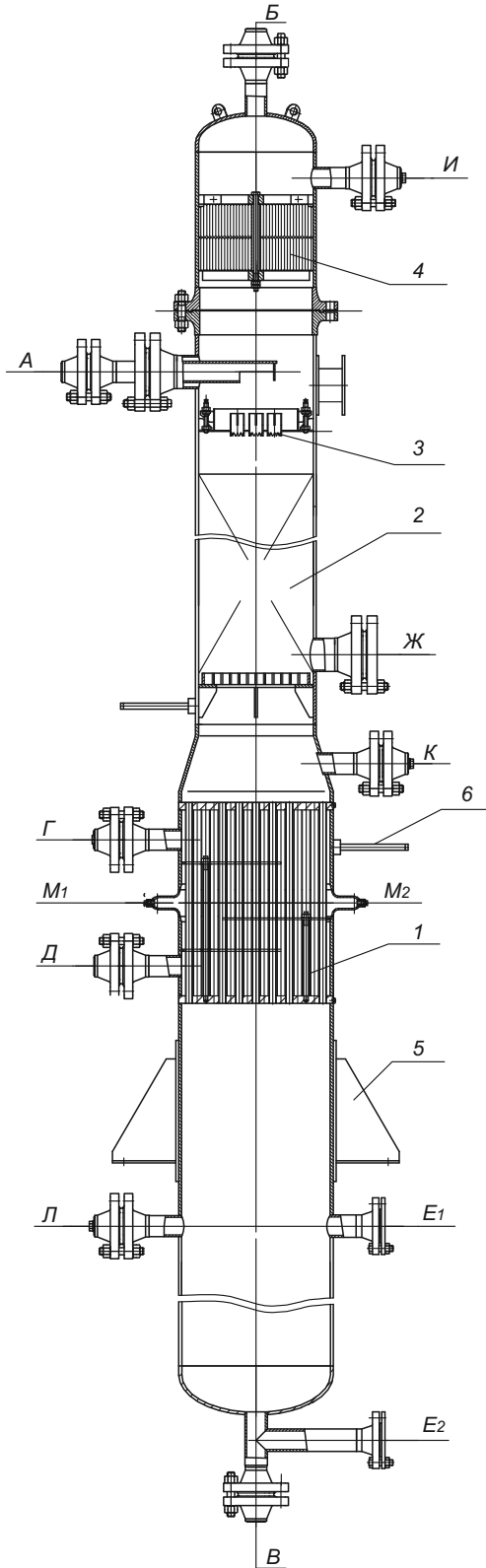

- 1 – Built-in heat exchanging device
- 2 – Mass-transferring device
- 3 – Distributor plate
- 4 – Mesh demister
- 5 – Support
- 6 – Verticality checking device

Designation	Description	Quantity
A	Feed inlet	1
Б	Petrol vapors return	1
B	Diesel fuel outlet	1
Г	Heavy residue inlet	1
Д	Heavy residue outlet	1
E <sub>1,2</sub>	For level gauge	2
Ж	Manhole	1
И	For pressure measurement	1
К	For temperature measurement	1
Л	For temperature control	1
M <sub>1,2</sub>	Process	2
H <sub>1,2</sub>	Process	2

Nozzles diameters are determined via process design.





# 136 Absorption Column

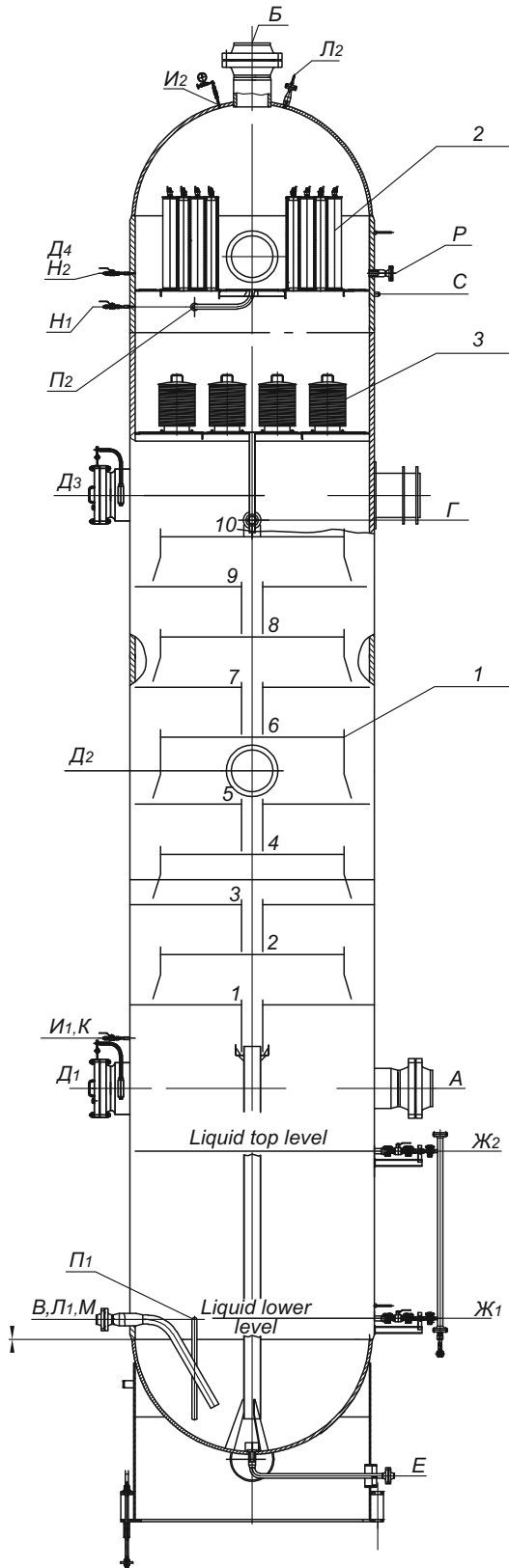

- 1 – Bidirectional bubble-cap tray
- 2 – Cartridge demister
- 3 – Cartridge filter with coalescers

The column is fitted with level, temperature, pressure, pressure drop visual control devices and equipment for transferring the signal to the control panel

Designation	Description	Quantity
A	Gas inlet	1
Б	Gas outlet	1
В	TEG drain	1
Г	TEG inlet	1
Д1-4	Manhole DN500	4
Е	Drain	1
Ж1,2	For level bridle	2
И1,2	For pressure gauge	2
К	For pressure measurement	1
Л1,2	For thermometer	2
М	For temperature measurement	1
Н1,2	Pressure drop measurement	2
П1,2	Condensate drain	2
Р	Process	1
С	Process	1
Т	Drain	1

Nozzles diameters are determined via process design.



# 137 Variable-Diameter Rectifying Column

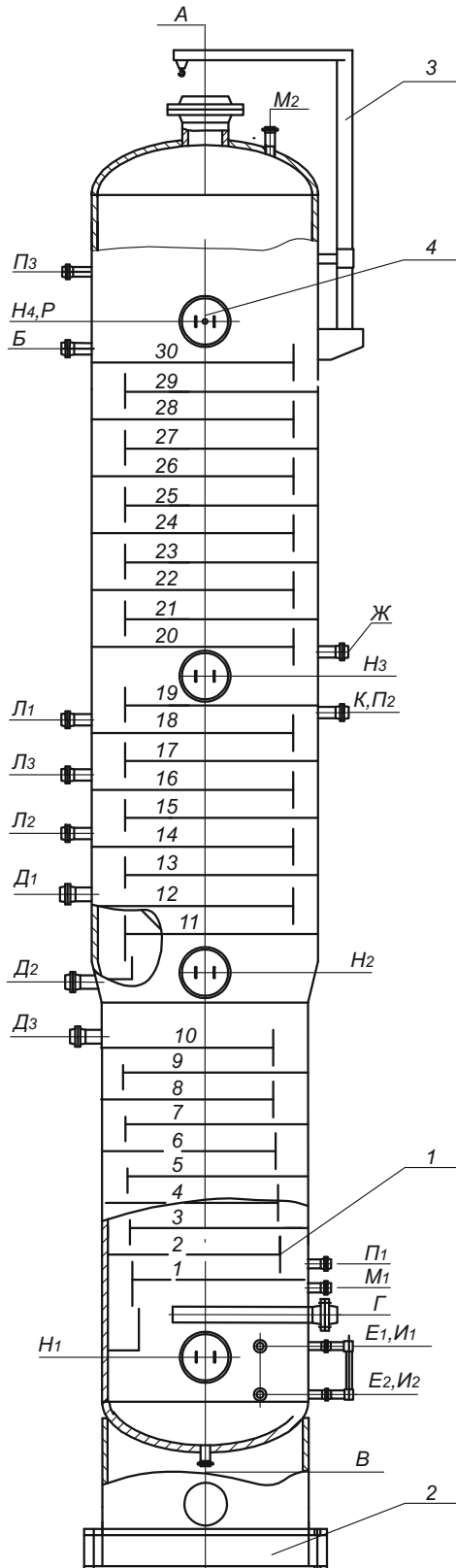

- 1 – Valve collar
- 2 – Support
- 3 – Load-lifting jib-crane for trays installation
- 4 – Manhole

Designation	Description	Quantity
A	Petro vapors outlet	1
Б	Reflux inlet	1
В	Fuel oil outlet	1
Г	Steam inlet	1
Д1-3	Feed inlet	3
Е1,2	For level gauge	2
Ж	Inlet from the stripping column	1
И1,2	For level regulator	2
К	Withdrawal to the stripping column	1
Л1,2,3	Feed inlet	3
М1,2	For pressure gauge	2
Н1,2,3,4	Manhole DN500	4
П1,2,3	For thermocouple	3
Р	Process	1

Nozzles diameters are determined via process design.



# 138 Rectifying Column

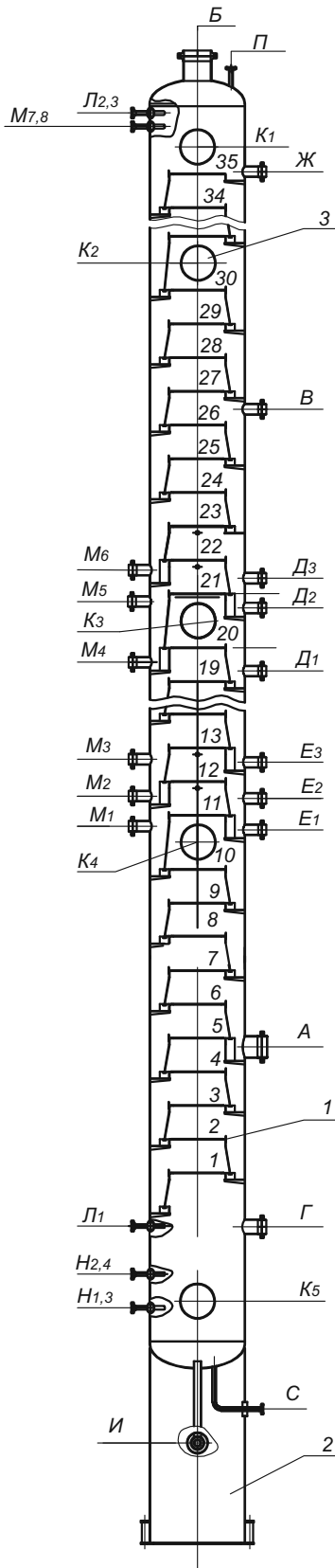

Consists of the following components:

- 1 – Shell
- 2 – Trays
- 3 – Support
- 4 – Manholes
- 5 – Process nozzles

The column is fitted with level, temperature, pressure control devices.

Designation	Description	Quantity
A	Raw materials inlet	1
Б	Petrol vapors outlet	1
B	Petrol vapors inlet	1
Г	Water steam inlet	1
Д1-3	Diesel fraction withdrawal	3
E1-3	Diesel fraction withdrawal	3
Ж	Petrol refluxing inlet	1
И	Fuel oil outlet	1
K1-5	Manhole	5
Л1-3	For pressure measuring	3
M1-8	For temperature measuring	8
H1-4	For level measuring	4
П	Air tap	2
C	Drain	1

Nozzles diameters are determined via process design.



# 139 Adsorption Column

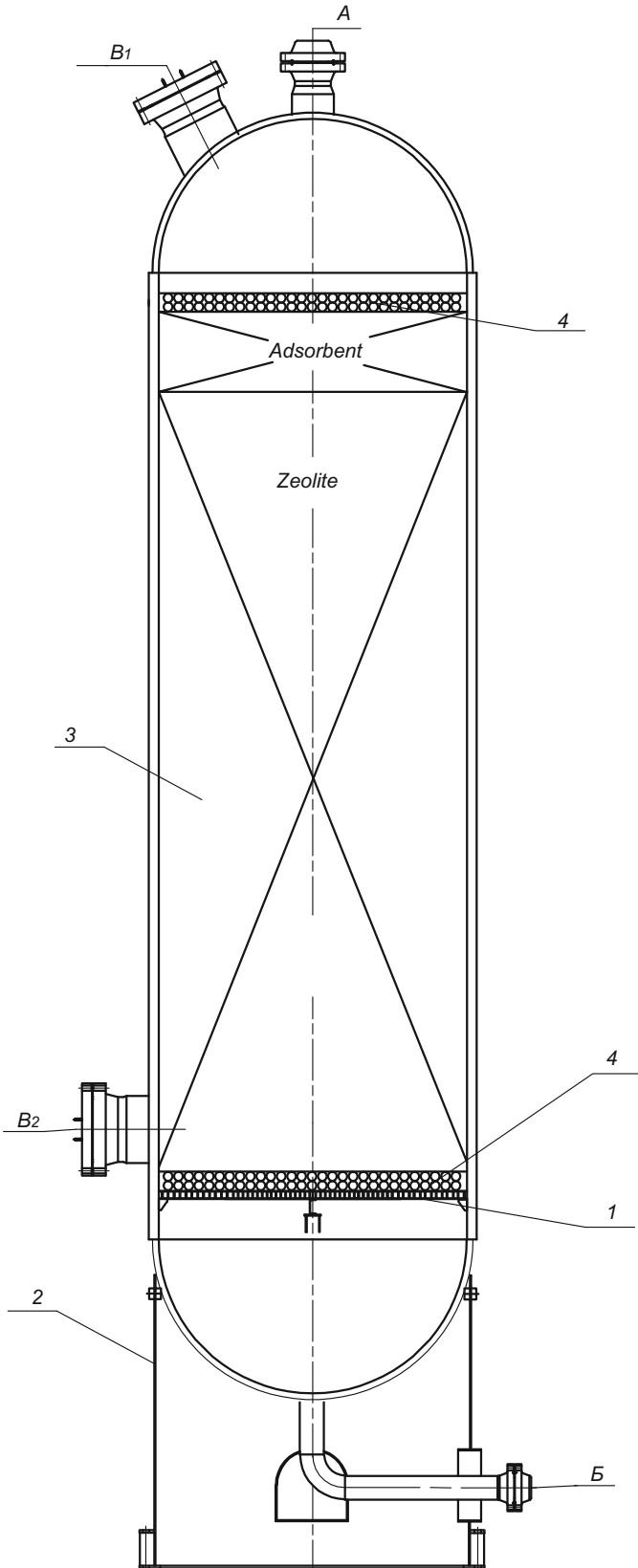

Meant for drying gas from residue liquid via adsorption.

- 1 – Dismountable grid (2 pcs.)
- 2 – Support
- 3 – Zeolite
- 4 – Manhole

Designation	Description	Quantity
A	Gas outlet to drying	1
Б	Dried gas outlet	1
B1,2,3	Manhole DN500	3

Zeolite grade and amount is chosen based on the process composition of gas.

Nozzles diameters are determined via process design.



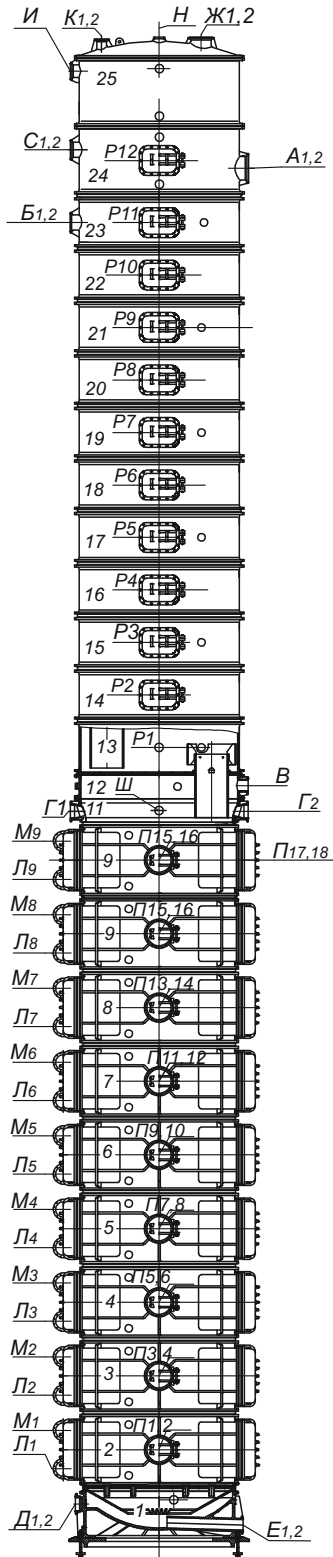

Aside from steel columns, a wide range of combined column-type equipment is produced for specialized productions: sodium, cake and by-products, hydrolytic etc.

Carbonization column Ø2800/Ø3000 mm consists of a cooling, mass-transferring and separation parts. The column is made of alloyed cast iron.

Heat exchanging tubes – BT1-0 alloy.

In the column's shell – pressure of 0.3 MPa temperature - 70°C.

In the tube side – pressure of 0.35 MPa temperature - 30°C.

The weight of the column is 201000 kg.

Designation	Description	Quantity
A1-2	Liquid inlet	2
Б1-2	Liquid inlet	2
В	Stand-by	1
Г1-2	Gas inlet	2
Д1-2	Gas inlet	2
Е1-2	Suspension outlet	2
Ж1-2	Gas outlet	2
И	Stand-by	1
К1	For safety valve	1
К2	Stand-by	1
Л1-9	Water inlet	9
М1-9	Water outlet	9
П1-18	Manhole	18
Р1-12	Manhole	12



# 141 Ø2800 mm Absorption Column

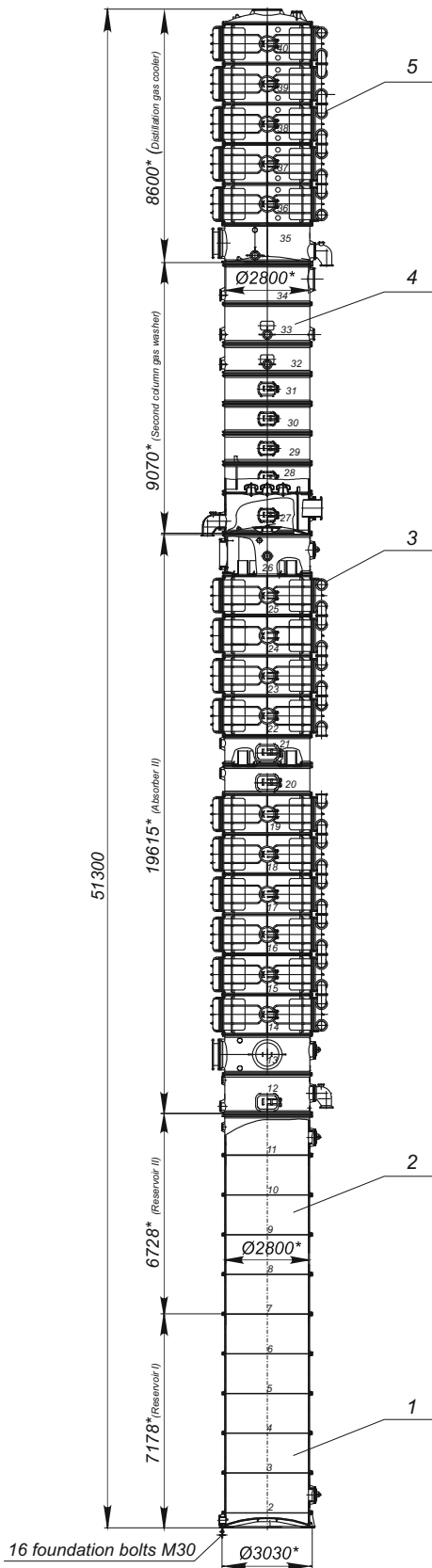

Comprises of apparatuses stacked on top of each other:

- 1 – Reservoir I
- 2 – Reservoir II
- 3 – Absorber II
- 4 – Second column gas washer
- 5 – Distillation gas cooler

Bubble-cap trays are installed in the washer.

The cooler is equipped with cooling pipes made of BT1-0 titanium alloy.

The absorption column shell is made of alloyed cast iron C425 and assembled from separate rings on flanged slots.



# 142 Distillation Column

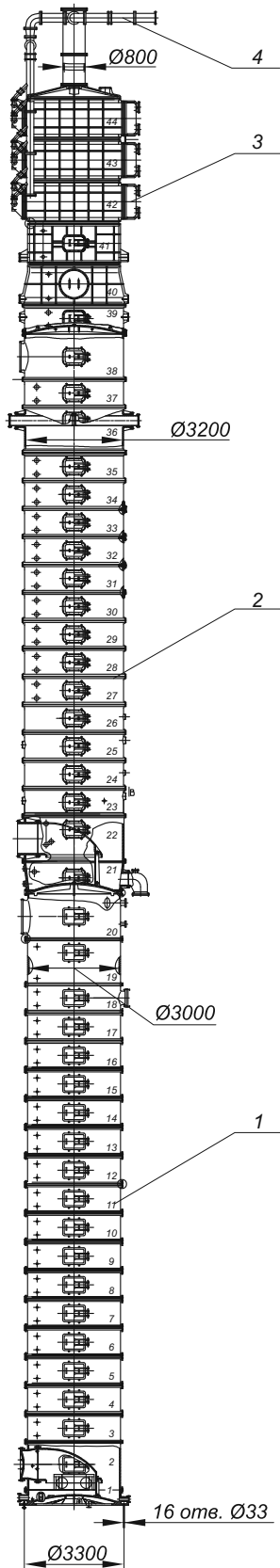

Comprised of apparatuses stacked on top of each other:

- 1 – Distiller Ø3000
- 2 – Distillation heat exchanger Ø3200
- 3 – Condenser
- 4 – Gas ties piping

The column is manufactured of alloyed cast iron C425, assembled from separate rings on flanged slots.

The distiller is meant for complete ammonia stripping from the mixer liquid using steam.

The distillation heat exchanger is meant for desorption of carbon dioxide from the filter liquid.

The condenser is meant for ammonia, carbon dioxide regeneration from the filter liquid and other sodium production liquids.

Weight of the column – 272350 kg.



## 143 Jib-Crane

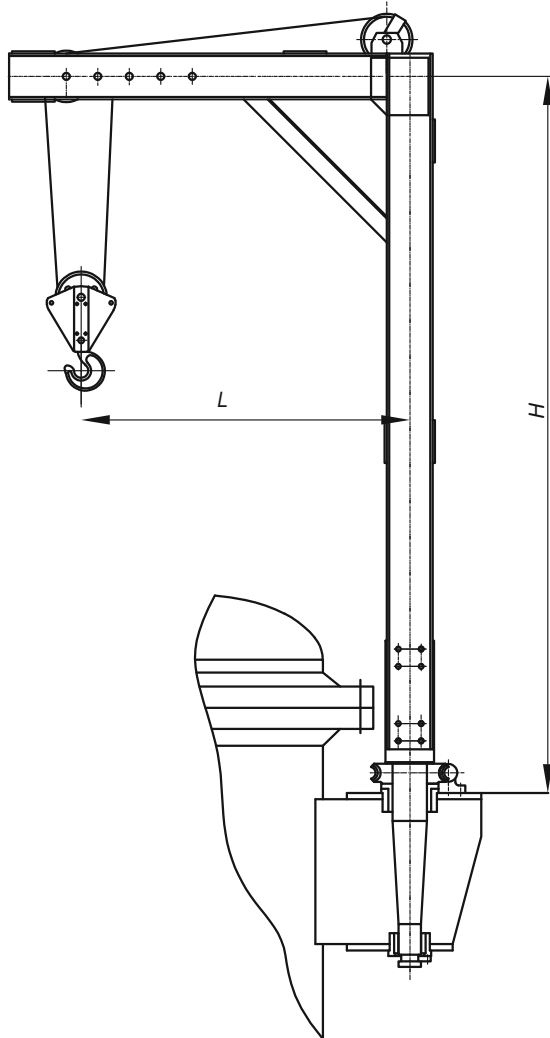

Jib-crane is used for mounting the internal components of columns.

Jib-cranes are fitted with a worm feeder facilitating lifting of loads.

Per the customer's decision, a jib-crane is supplied with various lifting capacities, with manual or electric drive.

Main jib crane with a manual drive parameters are given in the table.

**Main jib crane with a manual drive parameters**

Lifting capacity, t	Crane radius, mm	Height H, mm	Weight, kg
0.5	800	1600	177
	1200	2400	216
	1600	3200	250
	2000	4000	283
	2500	5000	325
1.0	1200	2500	384
	1600	3000	413
	2000	4000	456
	2500	5000	507
3.0	1600	3000	1300
	2000	4000	1405
	2500	5000	1511





# 144 Data Sheet for Column Order

Name and address of organization that filled out the data sheet:

Name of the enterprise, for which the column is developed:

Scheduled deadline for the development of the technical project, manufacture, installation and testing of the column:

No.	Questions	Units	Answers
1	2	3	4
1	Name of the apparatus; position NoNo. per the process diagram.	-	
2	Purpose of the apparatus		
3	Material balance of the column with mention of the physical state (liquid, steam), amount and composition of the separated liquid (feed), distillate, bottom liquid, intermediate bleeding and refluxing (for fractionating and distillation columns); the amount and composition of vapors (gases) and liquid on the apparatus inlet and outlet (for absorption column). Molecular weight of components to be stated in the material balance. Balances may be separated into a designated annex to the data sheet.		
4	Temperatures:		
	of column feed at the inlet	°C	
	of intermediate bleeding	°C	
	of vapors on top	°C	
	of the column	°C	
	of intermediate refluxing at the bottom of the column	°C	
	maximum allowable of the column bottom. (Specified in cases where it is limited.)	°C	
5	Absolute pressure:		
5.1	of the column top	mm Hg (kgf/cm <sup>2</sup> )	
5.2	of the column bottom	mm Hg (kgf/cm <sup>2</sup> )	
5.3	allowable pressure of the column bottom. (Specified in cases where it is limited.)	mm Hg (kgf/cm <sup>2</sup> )	
6	Type of trays, column packing of an existing equivalent industrial package.		
7	Type of process mixture: ideal, non-ideal. (Ideal mixture acts according to the Raoult's law.)		
8	Physical and chemical properties of: the processed mixture (feed), distillate, bottom liquid, reflux, intermediate bleeding and refluxing or their components under temperatures of feeding into the column and bleeding, the top and the bottom of the column:		
8.1	Density in liquid state.	kg/m <sup>3</sup>	
8.2	Heat capacity in liquid state.	kcal/kg	
8.3	Liquid vaporization or vapors condensation heat (see notes).	kcal/kg	
8.4	Liquid viscosity.	cPs	
8.5	Pressure of saturated vapors of components.	mm Hg (kgf/cm <sup>2</sup> )	
9	Total packing height.	m	
10	Location of the feed point per the packing height.	m	



# 145 Data Sheet for Column Order

1	2	3	4
11	Polymerization or thermal decomposition tendencies of processing products; possibility of sediments deposition on the columns' surfaces. Special requirements to the column design, resulting from polymerization, depositions and sediments, heating, cooling etc.		
12	Maximum allowable temperature and staying time of the product in the column cube (if limited).	°C	
		minutes	
13	Column installation location (indoors, outdoors, on an individual foundation, bridging, rack).		
14	Recommended material for the column parts in contact with the process medium, corrosion rate. Please specify whether or not the processing products cause the metal corrosive cracking.		
15	Installation location and types of embedded parts for instrumentation, short description, sketch.		
16	Location of sampling points in the column (NoNo. of trays, column cube etc.) and nozzles diameter.		
17	Possible fluctuations of the column load in % of the mean value (no more than ±30%).	± %	
18	Support type (skirt, suspension).		
18.1	Column skirt support height needed for normal drain of liquid from the column cube.	mm	
18.2	Installation height of suspension supports.	mm	
19	Climatic and special conditions in the construction location:		
	average temperature of the coldest five-days period	°C	
	design barometric pressure	mm Hg	
	wind pressure on the 10 m height	kgf/m <sup>2</sup>	
	seismicity	value	
20	Thickness and specific weight of heat insulation.	meter	
		kg/m <sup>3</sup>	
21	Location, dimensions and weight of maintenance platforms and other equipment attached to the column.		
22	Nozzles binding in the plane and per the height of columns.		
23	Coil, jacket surface area and purpose.	m <sup>2</sup>	
24	Foaming capacity of working mixtures: no, low, high foaming.		
25	Number of working days per year.		
26	Design pressure (absolute) and design temperature. Confirm if coincide with the operating values.	mm Hg (kgf/cm <sup>2</sup> )	
		°C	

**NOTE:**

- All answers in the data sheet and other data that the customer deems necessary to provide, can be attached in separate tables, a diagram or a text material.
- If processed liquids contain dissolved solids, or they are present as suspension, then the density, heat capacity, viscosity and vaporization heat shall be indicated for the mixture, not for individual components.

Signature of an authorized person



### **Certificates of Conformity:**

- ISO 9001:2008 Quality Management Certificate;
- OHSAS 18001-2007 Occupational Health and Safety Management Certificate;
- ISO 14001-2004 Environmental Management System Certificate.
- Certificates of Compliance with the requirements of ASME standards:
  - Manufacture Approval Certificate.

